

# AVANCE

Site Planning for AVANCE Systems 300-750 MHz

- User Guide

Version 006



Copyright © by Bruker Corporation

All rights reserved. No part of this publication may be reproduced, stored in a retrieval system, or transmitted, in any form, or by any means without the prior consent of the publisher. Product names used are trademarks or registered trademarks of their respective holders.

This manual was written by

Daniel Baumann and Stanley Niles

© Thursday, November 17, 2011 Bruker BioSpin GmbH

P/N: Z31276

DWG: 988006

For further technical assistance for this product, please do not hesitate to contact your nearest BRUKER dealer or contact us directly at:

Bruker BioSpin GmbH  
am Silberstreifen  
76297 Rheinstetten  
Germany  
Phone: + 49 721 5161 0  
FAX:+ 49 721 5171 01  
E-mail: [service@bruker.de](mailto:service@bruker.de)  
Internet: [www.bruker.com](http://www.bruker.com)

---

# Contents

<b>1</b>	<b>Introduction</b>	<b>7</b>
1.1	Units Used Within This Manual	7
<b>2</b>	<b>Safety</b>	<b>9</b>
2.1	The Magnetic Field	9
2.1.1	Exclusion Zone	10
2.1.2	Security Zone	10
2.1.3	Standards on Health and Safety in the Workplace	10
2.2	Ventilation	12
2.2.1	Regular Ventilation	12
2.2.2	Emergency Ventilation	12
2.2.3	Oxygen Level Sensors	13
2.3	Safe Handling of Cryogenic Substances	13
2.3.1	What is a Quench	14
2.3.2	Refill of Liquid Nitrogen	14
2.3.3	Refill of Liquid Helium	14
2.4	Earthquake Safety	15
2.5	Country-Specific Safety Regulations	15
2.6	Emergency Planning	15
2.6.1	Fire Department Notification	16
<b>3</b>	<b>Equipment</b>	<b>17</b>
3.1	Superconducting Magnet Components	17
3.2	Console and Other System Components	18
3.3	CryoProbe System (Optional)	19
3.4	CryoProbe Prodigy System (Optional)	20
3.5	Other Optional Components	21
<b>4</b>	<b>Magnet Access and Rigging</b>	<b>23</b>
4.1	Considerations for Off-loading on Site	24
4.2	Considerations for Transport to the NMR Room	25
4.3	Transport Dimensions and Weights	25
4.3.1	Magnet Transport Dimensions	25
4.3.2	Magnet Stand Transport Dimensions	26
4.3.3	Magnet Transport Weights	28
4.3.4	Spectrometer and Accessories Transport Dimensions	29
4.3.5	Spectrometer and Accessories Weights	30
4.4	Rigging Equipment	30
<b>5</b>	<b>Ceiling Height Requirements</b>	<b>33</b>
5.1	Helium Transfer Line	34
5.2	Minimum Ceiling Height	36
<b>6</b>	<b>Magnetic Stray Fields</b>	<b>39</b>
6.1	Horizontal Stray Fields	40
6.2	Vertical Stray Fields	41
6.3	Stray Field Plots	42
<b>7</b>	<b>Environment and Site Survey Measurement</b>	<b>43</b>
7.1	Vibrations	43
7.1.1	Vibration Guidelines	43

7.1.2	Vibration Damping Measures .....	44
7.2	Magnetic Environment .....	46
7.2.1	Minimum Requirements .....	46
7.2.1.1	Static Iron Distribution .....	46
7.2.1.2	Moveable Magnetic Material .....	46
7.2.2	Acceptable Environment .....	47
7.2.2.1	Static Objects .....	47
7.2.2.1.1	Recommendations for Static Magnetic Objects .....	47
7.2.2.2	Moving Objects .....	48
7.2.2.2.1	Recommendations for Movable Magnetic Objects .....	48
7.3	Electromagnetic Interference .....	48
7.3.1	Types of EMF Interference .....	48
7.3.2	DC EMF Interference .....	48
7.3.2.1	Measuring DC Fluctuating Fields .....	49
7.3.2.2	Guidelines for DC Interference .....	49
7.3.2.3	Reducing DC Interference .....	49
7.3.3	16-2/3 Hz and 50/60 Hz EMF Interference .....	50
7.3.3.1	Measuring 16-2/3 Hz and 50/60 Hz Fluctuating Fields .....	50
7.3.3.2	Guidelines for 16-2/3 Hz and 50/60 Hz Interference .....	50
7.3.3.3	Reducing 16-2/3 Hz and 50/60 Hz Interference .....	50
7.3.4	RF Interference .....	50
7.3.4.1	Measuring RF Fluctuating Fields .....	51
7.3.4.2	Most Commonly Studied Nuclei .....	51
7.3.4.3	Guidelines for RF Interference .....	51
7.3.4.4	Reducing RF Interference .....	51
<b>8</b>	<b>Utility Requirements .....</b>	<b>53</b>
8.1	Electrical Power Requirements .....	53
8.1.1	CryoProbe Utility Requirements .....	55
8.2	Telecommunication .....	56
8.3	Compressed Gas .....	56
8.3.1	General Requirements .....	56
8.3.2	Compressed Gas Options .....	56
8.3.3	Gas Requirements For Accessories .....	57
8.3.3.1	Compressed Gas Requirements .....	57
8.3.4	Compressed Gas Specifications .....	57
8.3.5	Compressed Air System .....	58
8.3.5.1	Air Compressors .....	59
8.3.5.2	Dryers .....	60
8.3.5.2.1	Refrigeration Dryers .....	60
8.3.5.2.2	Absorbtion Dryers .....	60
8.3.5.3	Filters .....	61
8.3.6	Helium Gas Recovery System .....	61
8.4	Water .....	61
8.5	Lighting .....	62
8.6	HVAC (Heating Ventilation Air Conditioning) .....	62
8.6.1	Avance System Stability .....	62
8.6.2	Atmospheric Pressure Changes .....	63
8.7	Emergency Ventilation During Installation and Quenches .....	63

8.7.1	Emergency Exhaust Solutions.....	65
8.8	Fire Detection System and Fire Extinguishers .....	67
<b>9</b>	<b>Floor Plan .....</b>	<b>69</b>
9.1	Size and Mass of Equipment.....	69
9.1.1	Magnet Dimensions.....	70
9.1.2	Magnet Dimensions and Total Weight .....	71
9.2	Magnet Location.....	72
9.3	Minimum Floor Capacity.....	72
9.4	Floor Types.....	72
9.5	Magnet Platform .....	73
9.6	Magnet Pits.....	73
9.7	Maximum Field Strengths for NMR Equipment .....	74
9.8	Automation Considerations .....	75
9.9	Cabinet Position .....	75
9.10	Worktable Position.....	76
9.11	Service Access Requirements.....	76
<b>10</b>	<b>The CryoProbe System .....</b>	<b>79</b>
10.1	CryoCooling Unit .....	81
10.2	Helium Compressors.....	81
10.2.1	Available Models .....	81
10.2.1.1	Helium Compressor - Indoor Water Cooled .....	82
10.2.1.2	Helium Compressor - Indoor Air Cooled.....	82
10.2.1.3	Helium Compressor - Outdoor Air Cooled.....	83
10.2.2	Space Requirements and Specifications .....	83
10.2.2.1	Indoor Helium Compressors.....	83
10.2.2.2	Outdoor Helium Compressors .....	84
10.3	Helium Cylinders .....	85
10.4	Summary of CryoProbe Options.....	85
<b>11</b>	<b>Installation.....</b>	<b>89</b>
11.1	Overview.....	89
11.2	Accessibility.....	89
11.3	Installation Requirements Checklist .....	90
11.4	Installation Procedure.....	90
11.4.1	Magnet Assembly .....	90
11.4.2	Magnet Evacuation and Flushing with Nitrogen Gas.....	91
11.4.3	Cooling the Magnet to Liquid Nitrogen Temperatures .....	91
11.4.4	Cooling the Magnet to Liquid Helium Temperatures.....	91
11.4.5	Sub-cooling and Charging the Magnet.....	91
	<b>List of Figures .....</b>	<b>95</b>
	<b>List of Tables.....</b>	<b>97</b>
	<b>Glossary .....</b>	<b>99</b>
	<b>Index .....</b>	<b>101</b>



# 1 Introduction

This manual contains information about site planning and preparation prior to delivery of a Bruker AVANCE system. The manual should be read through carefully as mistakes made initially may be costly to remedy at a later stage.

The systems covered by this manual are AVANCE spectrometers in the range of 300-750 MHz. A **separate manual** is available for 800-950 MHz systems.

The chapters within this manual deal with various points that need to be considered for successful system operation. They have been included to familiarize you with general principles of successful site planning. For specific questions that may not be addressed in this manual, or for further information on a topic, do not hesitate to contact your local Bruker office. Please also review the Installation Questionnaire at the end of the manual.

Note that site planning is not only relevant for the installation of a new system, rather also by any changes in the equipment or devices, and by any renovations or room changes.

## 1.1 Units Used Within This Manual

The SI Unit Tesla (mT) is used throughout this manual whenever magnetic field strengths are discussed. Some readers may however be more familiar with the Gauss (G) Unit.

For comparison the conversion fact is: 1 mT=10 G

Likewise the unit kilowatt is used for the measure of heat energy (e.g. amount of heat generated by a device per hour). Some readers may be more familiar with these measurements in BTU/hour:

For comparison the conversion factor is: 1 BTU/hour=0.000293 kW.

(BTU = British Thermal Unit which is the required heat to raise 1 pound of H<sub>2</sub>O by 1 degree Fahrenheit).

Wherever possible both the metric and American (North and South) measure units have been used throughout this manual. In most cases the weights and measures have been rounded upwards where necessary. The following table offers the common metric to American conversion factors used in this manual:

Measure	Metric Units	American Standard Units	Conversion Factor (rounded to nearest hundredth)
<b>Linear</b>	meter (m)	feet (ft.)	1 m = 3.28 ft.
	centimeter (cm)	inch (in.)	1 m = 39.37 in. 1 cm = 0.394 in.
<b>Distance</b>	kilometer (km)	mile (mi.)	1 km = 0.62 mi.
<b>Area</b>	square meter (m <sup>2</sup> )	square foot (ft <sup>2</sup> )	1 m <sup>2</sup> = 10.76 ft <sup>2</sup>
<b>Volume</b>	cubic meter (m <sup>3</sup> )	cubic foot (ft <sup>3</sup> )	1 m <sup>3</sup> = 35.32 ft <sup>3</sup>
	liter (l)	quart (qt.)	1 l = 1.06 qt. (liquid)
<b>Weight</b>	kilogram (kg)	pounds (lbs.)	1 kg. = 2.21 lbs.

# Introduction

Measure	Metric Units	American Standard Units	Conversion Factor (rounded to nearest hundredth)
<b>Pressure</b>	bar	pounds/square inch (psi)	1 bar = 14.51 psi
		atmosphere (ATM)	1 bar = 0.99 ATM (standard)
<b>Flow</b> (e.g. gas flow)	cubic meter/minute (m <sup>3</sup> /min.)	cubic feet/minute (ft <sup>3</sup> /min.)	1 m <sup>3</sup> /min. = 35.32 ft <sup>3</sup> /min.
<b>Temperature</b>	°C	°F	$F = C \times 1.8 + 32$
	°F	°C	$C = (F - 32) / 1.8$
	°C	K	$K = C + 273.15$
	K	°C	$C = K - 273.15$
	°F	K	$K = (F + 459.67) / 1.8$
	K	°F	$F = K \times 1.8 - 459.67$
<b>Magnet Field Strength</b>	Tesla (T)	Gauss (G)	1 T = 10 <sup>4</sup> G
Heat Energy	BTU/hour	kW	1 BTU/hour = 0.000293 kW
BTU = British Thermal Unit which is the required heat to raise 1 pound of H <sub>2</sub> O by 1 degree Fahrenheit. SI = International System of Units.			

Table 1.1: Metric to American Conversion Factors

## 2 Safety

These safety notes must be read and understood by everyone who comes into contact with superconducting NMR Magnet Systems. Proper training procedures must be undertaken to educate all people concerned with such equipment about these requirements. It is essential that clear notices are placed and maintained to effectively warn people that they are entering a hazardous area. Please refer to **Bruker's General Safety Considerations for the Installation and Operation of Superconducting Magnets**, available from Bruker.

### 2.1 The Magnetic Field

Since the magnetic field of the NMR magnet system is three dimensional, consideration must be given to floors above and below the magnet, as well as to the surrounding space on the floor the magnet resides on. The magnetic field exerts attractive forces on equipment and objects in its vicinity. These forces, which increase drastically approaching the magnet, may become strong enough to move large equipment and to cause small objects or equipment to become projectiles.

**It is important to consider personnel and equipment in the rooms above, below, and adjacent to the room where the magnet will be located:**

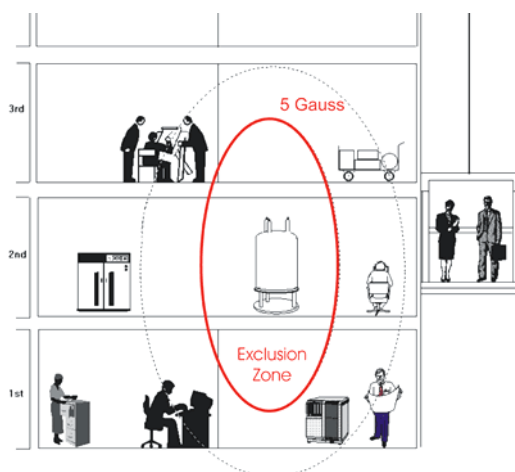

Figure 2.1: Stronger Stray Fields in Vertical Direction than in Horizontal Direction

The magnetic field may affect the operation of electronic **medical implants** such as pacemakers, if exposed to fields greater than 5 gauss. Medical implants such as aneurysm clips, surgical clips or prostheses may also be attracted. Further care must be taken around changing fields (e.g. pulsed gradient fields). Eddy currents could be generated in the implant resulting in heat generation and/or unwanted torques.

Ensure that all **loose ferromagnetic objects** are outside the 5 gauss (0.5 mT) field zone of the magnet before the magnet is ramped to field. Human experience and reaction speed are totally inadequate to cope with the extremely nonlinear forces the magnet exerts on iron objects. Therefore no ferromagnetic objects should be allowed to enter the magnet room after the magnet is energized.

## 2.1.1 Exclusion Zone

---

The **Exclusion Zone** is the area inside the magnet's 5 gauss (0.5 mT) field line, extended in all directions, including rooms above and below the magnet area.

Individuals with cardiac or other medically active implants must be prevented from entering this area. The exclusion zone must be enforced with a combination of warning signs and physical barriers.

## 2.1.2 Security Zone

---

The **Security Zone** is usually confined to the room that houses the magnet.

**Ferromagnetic objects** should not be allowed inside the security zone to prevent them from becoming projectiles.

## 2.1.3 Standards on Health and Safety in the Workplace

---

Guidelines on Limits of Exposure to Static Magnetic Fields are introduced by the ICNIRP (International Commission on Non-Ionizing Radiation Protection). They give separate guidance for occupational exposures and exposure of general public.

### Occupational Exposures:

It is recommended that occupational exposure of the head and the trunk should not exceed a spatial peak magnetic flux density of 2 mT (20 Gauss) except for the following circumstance:

For work applications for which exposures above 2 mT (20 Gauss) are deemed necessary, exposure up to 8 mT (80 Gauss) can be permitted if the environment is controlled and appropriate work practices are implemented to control movement-included effects. Sensory effects due to the movement in the field can be avoided by complying with basic restrictions set in the ELF guidelines. When restricted to the limbs, maximum exposures of up to 8 mT (80 Gauss) are acceptable.

### General Public exposures:

Based on scientific knowledge on the direct effects of static fields on humans, acute exposure of the general public should not exceed 400 mT (any part of the body). However, because of potential indirect adverse effects, ICNIRP recognizes that practical policies need to be implemented to prevent inadvertent harmful exposure of people with implanted electronic medical devices and implants containing ferromagnetic materials, and injuries due to flying ferromagnetic objects, and these considerations can lead to much lower restriction levels, such as 0.5 mT (IEC 2002). The exposure limits to be set with regard to these non biological effects are not, however, the duty of ICNIRP.

\* From ICNIRP Guidelines published 2009 (<http://www.icnirp.de/documents/statgdl.pdf>)

Example:

The European Community did release a **Directive 2004/40/EC** on the minimum health and safety requirements regarding the exposure of workers to the risks arising from physical agents (electromagnetic fields).

This directive, depending on the frequency, gives the following physical quantities to specify the exposure limit values of electromagnetic fields:

Frequency Range	Magnetic Field Strength H	Magnetic Flux Density B
0...1 Hz	$1.63 \times 10^5$ A/m	0.2 T or 200 mT

*Magnetic field strength* is a vector quantity (H), which, together with the magnetic flux density, specifies a magnetic field at any point in space. It is expressed in Ampere per metre. (A/m).

*Magnetic flux density* is a vector quantity (B), resulting in a force that acts on moving charges, expressed in (T). In free space and in biological materials, magnetic flux density and magnetic field strength can be interchanged using the equivalence  $1 \text{ A/m} = 4\pi \cdot 10^{-7} \text{ T}$ .

In Germany, regulation BGV B11 describes the maximum exposure doses in two basic tables. Table 2.1 applies to situations under the standard precautionary conditions, whereas Table 2.2 applies to systems with field strengths above 5 Tesla and can only be applied to certain subgroups of people, which meet nonstandard precautionary conditions. Details on the different precautionary conditions and subgroups of people are given in the document BGV B11 document.

Exposure	Maximum Magnetic Flux Density
Average over 8 hours	212 mT
Peak values for head and body	2T
Peak values for extremities	5T
<i>Standards on health and safety in the workplace for standard precautions and users, according to BGV B1.</i>	

Table 2.1: BGV B11 Standards for Standard Precautions and Users

Exposure	Maximum Magnetic Flux Density
Average over 8 hours	4T
Peak values for head and body	Table 2.1 is valid
Peak values for extremities	10T
<i>Health and safety standard in the workplace applicable under special conditions to selected subgroups of people, according to BGV B11.</i>	

Table 2.2: BGV B11 Standards Under Special Conditions for Selected Subgroups

The next table shows the maximum retention periods within different stray field regions below 5 Tesla for standard precautionary situations. The corresponding spatial regions within and around the super-conducting magnet can be worked out from the stray-field plots of the magnet being used.

Magnetic Flux	Retention Period	Parts of the Body
5T	< 20 Minutes	Extremities
4T	< 25 Minutes	Extremities
3T	< 34 Minutes	Extremities
2T	< 52 Minutes	Head/Body
1T	< 1 Hour 42 Minutes	Head/Body
0.5T	< 3 Hours 23 Minutes	Head/Body
0.3T	< 5 Hours 39 Minutes	Head/Body
<i>We do not take any responsibility for the numbers given in this table!</i>		

Table 2.3: Example of Maximum Retention Periods

If higher field strength is accessible inside the magnet by a user's extremities, a corresponding table for non-standard situations can be worked out from the table above. However, the analysis must be carried out in a more detailed and differentiated manner and a greater number of more important conditions must be strictly fulfilled.

## 2.2 Ventilation

---

Superconducting magnets use liquid nitrogen and liquid helium as cooling agents. During normal operation of the magnet system it can be expected that a boil-off of liquid cryogenes will occur:

- A normal boil-off of liquids contained in the magnet will occur based on the established boil-off specifications.
- A boil-off of cryogenes will occur during regular refills with liquid nitrogen and liquid helium.

A very large increase in volume accompanies vaporization of the cryogenic liquids into gas. The cryogenic gas to liquid volume ratios are approximately 740:1 for helium; 680:1 for nitrogen. Due to this large increase in volume the vapor may displace the air in an enclosed room. If someone is in the room, this may lead to **asphyxiation**. To prevent this and other dangers, the following minimum general safety rules concerning ventilation apply:

- Cryogenic liquids, even when kept in insulated storage dewars, remain at a constant temperature by their respective boiling points and will gradually evaporate. These **dewars** must always be allowed to vent or dangerous pressure buildup will occur.
- Cryogenic liquids must be handled and stored in well ventilated areas.
- **Exit doors must open to the outside**, to allow safe exit in the event the room becomes pressurized by helium gas during a magnet quench.
- Room layout, ceiling clearance and magnet height must be such that an easy **transfer of liquid** nitrogen and helium is possible. This will considerably reduce the risk of accidents.

### See also

- 📖 Oxygen Level Sensors [▶13]

### 2.2.1 Regular Ventilation

---

Regular HVAC systems should be able to handle 3 - 5 room air exchanges per hour, and provide temperature stability of +/- 1°C for 300-500 MHz systems, and +/- 0.5°C for 600 MHz and above,. Please refer to HVAC (Heating Ventilation Air Conditioning) [▶62] for more details.

### 2.2.2 Emergency Ventilation

---

Depending on the actual size of the magnet room, a large amount of He and/or N<sub>2</sub> gas could displace the air in the room. This is possible during the initial cooling of the magnet, during follow-up cryogen fills, or in case of a quench. Therefore, an emergency exhaust system may be required to avoid asphyxiation. Please refer to the section Emergency Ventilation During Installation and Quenches [▶63], for more details.

## Pits

**Pits:**

As discussed in HVAC (Heating Ventilation Air Conditioning) [▶ 62], continuous air flow (exhaust) is required within the confines of a magnet pit. A low exhaust down in the pit is recommended. Additional emergency ventilation may also be necessary, particularly if the pit is >1.09m (3.5') deep (average mouth-height of a person). Since nitrogen gas cannot be detected by the human senses, an oxygen sensor mounted in the pit will trigger an increased rate of exhaust.

### 2.2.3 Oxygen Level Sensors

Oxygen (O<sub>2</sub>) monitors, or level sensors, are required in the magnet room to detect low levels of O<sub>2</sub> due to cryogenic gases. At a minimum the following sensors must be provided:

- One oxygen level sensor must be above the magnet, to detect low oxygen levels caused by high helium gas levels.
- One oxygen level sensor approx. 30 cm off the floor of the magnet room.
- One additional oxygen level sensor approx. 30 cm off the bottom of the pit, in case the magnet is located inside a pit.

These monitors and sensors generally must be located outside the 0.5 mT (5 G) line. Check with original equipment manufacturer for information on the effects of magnet fields on these devices.

Please refer to Emergency Ventilation During Installation and Quenches [▶ 63] for more information on ventilation and exhaust solutions.

## 2.3 Safe Handling of Cryogenic Substances

Superconducting magnets use liquid helium and nitrogen as cooling agents, keeping the magnet core at a very low temperature. The safe handling of cryogenic liquids requires some knowledge of the physical properties of these liquids, common sense, and sufficient understanding to predict the reactions of such liquids under certain physical conditions.

Cryogenic liquids, even when kept in insulated storage vessels (dewars), remain at a constant temperature by their respective boiling temperature. As a result, a fraction of the liquid constantly evaporates into the gas phase, leading to a pressure build-up inside the storage dewar. A very important characteristic of cryogenics is their enormous increase in volume during the conversion from liquid to gaseous phase. This conversion follows a raise in gas temperature starting at the boiling temperatures of the cryogenic liquids and going up towards room temperature.

The gases are nontoxic and completely harmless as long as adequate ventilation is provided to avoid suffocation. During normal operation only **3-5 m<sup>3</sup>/day** of nitrogen are evaporated, but during a quench, an extremely large quantity of helium gas is produced within a short time.

Cryogenic liquids must be handled and stored in **well ventilated areas**. Containers for cryogenic liquids must be constructed with non-magnetic materials and should be specifically designed for use with particular cryogenics. Be sure to read and follow any specific instructions provided by the container manufacturer concerning their individual products.

## 2.3.1 What is a Quench

---

A magnet **quench** is the breakdown of superconductivity in a partially or fully energized magnet. The stored field energy is transformed into heat, leading to a fast evaporation of liquid helium. During a quench, an extremely large quantity of helium gas (i.e. 43 m<sup>3</sup> to 595 m<sup>3</sup> depending on the magnet type) is produced within a short time.

Although these gases are inert, if generated in large enough quantities, they can displace the oxygen in the room causing potential danger of suffocation (refer to Emergency Ventilation During Installation and Quenches [ 63]).

## 2.3.2 Refill of Liquid Nitrogen

---

**Keep contact with air at a minimum.** When liquid nitrogen is exposed to air, it can condense and become as hazardous as liquid oxygen. The **pressure relief valve** for the nitrogen vessel should be mounted at all times, even when the vessel is being refilled. Special attention is required for the **transportation of cryogenics by elevator**, no one should be allowed to be in the elevator with a cryogen dewar.

When the vessel is being refilled, liquid nitrogen should not be allowed to spill onto the room temperature bore closure flanges. Place gum rubber or Teflon tubes on the nitrogen neck tubes during refill. The transfer should be stopped immediately when the vessel is full. Failure to observe this can lead to the freezing of the O-rings and a subsequent vacuum loss of the magnet cryostat.

The liquid cryogen transport dewars used to refill the magnet must be of the low pressure type. **Never use high pressure gas-packs.** The dewar must have a fixture for pressurizing and transferring via a stainless steel or corrugated plastic tube (10 mm inner diameter). Where possible the dewar should be self pressuring. The typical transport dewar pressure for transferring liquid nitrogen is 0.10 - 0.20 bar (1-3 psi), the maximum 0.35 bar (5 psi).

## 2.3.3 Refill of Liquid Helium

---

Liquid helium is the coldest of all cryogenic liquids, therefore it will condense and solidify any other gas (air) coming in contact with it. The consequent danger is that pipes and vents may become blocked with frozen gas. Vacuum insulated pipes should be used for transferring liquid helium. The helium vessel should be checked weekly for helium level and overpressure.

Liquid helium must be kept in specially designed storage or transport dewars. A one-way valve is supplied to avoid air or moisture from entering the helium vessel. This is to prevent ice from building and plugging the neck tubes. The 0.2 bar valve must be mounted at all times even during a helium transfer.

A helium gas cylinder is typically used to pressurize the liquid helium transport dewars during the helium refills. The helium gas cylinder should never be brought close to the magnet and should always be kept well outside the 5 Gauss line. The gas cylinder should be secured to a wall or structural column well outside the 5 Gauss line to prevent a dangerous accident.

 **CAUTION****Danger of cold burns or freezing during the transfer of liquid helium.**

During the transfer of liquid helium it is possible that cold burns or freezing may occur.

- 
- ▶ The transfer of liquid helium can be done easily and safely, provided the helium transfer line is in good condition, is handled correctly, and the transfer pressure does not exceed 3.5 psi (0.24 bar).
  - 1. Never connect a warm helium transfer line to the magnet as the warm helium gas could disturb the magnet temperature.
  - 2. Always allow the helium transfer line to cool down to helium temperature before connecting it to the short end inserted into the helium fill port.
  - 3. Adequate protection and clothing is required at all times when handling, transferring, or operating near cryogenic fluids.

## 2.4 Earthquake Safety

---

In regions where there is a potential risk of earthquakes, additional precautions should be taken to reduce the chance of personal or property damage through movement or tipping of the magnet.

Many countries or regions have documented regulations, including building codes, regarding earthquakes. Before installing a magnet system, it is highly advisable that you check with local authorities on whether your area is prone to earthquakes and if there are any regulations in effect.

If your area is regarded as an earthquake area there are several shock absorbing methods or riggings available to reduce the likelihood of damage during an earthquake. Please contact Bruker for more information on earthquake securing equipment.

## 2.5 Country-Specific Safety Regulations

---

In addition to the above safety precautions, any country-specific safety regulations for operating NMR systems must be fulfilled. These may include, for example, regulations on:

- Facilities of a controlled access area around the magnet
- Working conditions at computer stations
- Use of anesthesia gases
- Handling of laboratory and transgenic animals

## 2.6 Emergency Planning

---

Due to the strong magnetic fields and presence of cryogens when using NMR systems, it is important to define and communicate what to do in case of problems or an emergency. An **Emergency Plan** can be defined as a documented set of instructions on what to do if something goes wrong. Emergency Plans are often defined as part of the Standard Operating Procedures (SOP), or as a stand-alone document. In any case every NMR laboratory should have an Emergency Plan in effect in case of problems or emergencies.

As every organization has its own policies and procedures, as well as varying laboratory layouts, an Emergency Plan should be individually defined for each laboratory as appropriate. Upon request Bruker can provide useful information on emergency planning.

## 2.6.1 Fire Department Notification

---

It is recommended that the magnet operator introduce the fire department and/or local authorities to the magnet site. It is important that these organizations be informed of the potential risks of the magnet system, i.e. that much of the magnetic rescue equipment (oxygen-cylinders, fire extinguishers, axe's etc.) can be hazardous close to the magnet system. On the other side, their expertise and experience can be invaluable in creating an Emergency plan.

- Within a NMR laboratory CO<sub>2</sub> magnetic fire extinguishers must NOT be used.
- Breathing equipment which uses oxygen tanks made out of magnetic material can be life threatening when used close to a magnet system which still has a magnetic field present.
- Helium gas escaping from the system must not be mistaken for smoke. Instruct the fire department and technical service not to „extinguish“ the magnet system with water. The outlet valves could freeze over and generate excess pressure within the system.
- NMR laboratory windows which are accessible during an emergency must be clearly marked with warning signs, visible from the outside.

# 3 Equipment

This section describes the types and functions of the various sub-systems that are delivered as part of our AVANCE UltraStabilized NMR systems. These include the following:

- Superconducting Magnet Components [[▶ 17](#)].
- Console and Other System Components [[▶ 18](#)].
- CryoProbe System (Optional) [[▶ 19](#)].
- Other Optional Components [[▶ 21](#)].

## 3.1 Superconducting Magnet Components

---

This section describes the basic operation of an NMR superconducting magnet.

<b>Purpose:</b>	The superconducting magnet is a complex system producing a very strong, homogeneous, and stable magnetic field, which is required for NMR.
<b>Magnet temperature:</b>	The magnet uses both liquid nitrogen and liquid helium. The magnet coil is immersed in liquid helium inside a dedicated helium vessel. Liquid nitrogen fills a different vessel and reduces the helium evaporation rate.
<b>Magnet current:</b>	After the initial charging with electrical current, the magnet runs in persistent mode. The current runs in a closed loop inside the system and the magnet itself is no longer connected to a continuous power supply.
<b>Maintenance:</b>	Magnet maintenance consists of refilling the system with cryogenic fluids at defined time intervals.

### See also

- 📄 [Compressed Gas \[\[▶ 56\]\(#\)\]](#)

## 3.2 Console and Other System Components

The next table lists the various parts of the console, monitoring & control units. Please also refer to the floor plan diagrams beginning in the chapter Floor Plan [ 69]. These scaled diagrams provide an idea of where the various pieces of NMR equipment should be placed.



Figure 3.1: Spectrometer and Magnet Control

1.	The <b>AVANCE console</b> main cabinet, where the actual NMR data acquisition is performed.
2.	The <b>Uninterruptable Power Supply (UPS)</b> feeds the BMPC II and provides continuous power in case of power failure. The UPS also acts as a power conditioner. It is recommended to have the UPS on emergency power.
3.	The <b>probe</b> , which is designed to hold the sample, transmit radio frequency signals which excite the sample and receive the emitted response. The probe is inserted into the bottom of the magnet and sits inside the room temperature shims. Coaxial cables carry the excitation signals from the console amplifiers to the probe and the NMR signal back from the sample to the receiver.
4.	The <b>Bruker Magnet Pump Control (BMPC II - high frequency systems only)</b> , which monitors the magnet status and cryogenic parameters, interfaces between the magnet, pump system, and user. The BMPC II includes the pumps that drive the Joule-Thompson cooling unit in order to maintain the temperature of ~2K.
5.	The <b>BCU-I Unit</b> cools VT gas to allow proper sample temperature regulation. The unit reduces the temperature of the air input (supplied by the variable-temperature unit) and provides cooling of the NMR sample within the magnet to at least -5 °C for a room temperature of 25 °C.
6.	The <b>BCU-II Unit</b> delivers very cold gas, either nitrogen or dry air, through a flexible isolated non-magnetic transfer line. It is possible to control the sample temperature down to -60°C inside the probe for solid or liquid NMR applications.
7.	The <b>workstation</b> acts as the operational computer for the user processing NMR data and sending/receiving data to/from the acquisition computer in the main console.
8.	<b>Air compressor</b> (not pictured). The air compressor should have a maximum duty cycle of 50%. When the area where the compressor is located is very humid, air conditioning should be used. If floor vibrations are a problem, insulation should be used.

### 3.3 CryoProbe System (Optional)

The Bruker CryoProbe™ Accessory for the AVANCE NMR spectrometers offers dramatic increases in signal to noise ratio, stability, and ease of use. For site planning details for the CryoProbe accessory, refer to The CryoProbe System [79].

The CryoProbe system consists of the following components:



Figure 3.2: CryoProbe System

1.	The <b>CryoProbe</b> represents the NMR probe inside the magnet bore, and is cooled by cryogenic helium gas. The CryoProbe maximizes efficiency and reduces thermal noise, thus enhancing the signal-to-noise ratio.
2.	The <b>CryoCooling unit</b> contains a cryocooler, a cryocontroller, a vacuum system, and He transfer lines. The unit cools compressed helium gas by expansion and provides and maintains the vacuum insulation. The unit also supervises all CryoProbe operations.
3.	The research grade <b>Helium gas cylinder</b> provides research grade helium gas (99.9999%) at high pressure (min. 200 bar) for flushing the probe prior to a cool-down cycle. The cylinder includes a regulator, an outlet valve, and a charging hose.
4.	A <b>transfer line</b> supports provide support for the probe and isolates the probe against vibrations.
5.	The <b>He compressor</b> provides compressed helium gas to the CryoCooling unit. The compressor connects to the CryoCooling unit by means of helium gas pressure lines. The indoor water-cooled helium compressor is shown to the right. Other models, including indoor air-cooled and outdoor air-cooled, are available.

## 3.4 CryoProbe Prodigy System (Optional)

The CryoProbe Prodigy is a new CryoProbe generation designed specifically for AVANCE III spectrometers. Costing significantly less than a conventional CryoProbe, the broadband CryoProbe Prodigy uses nitrogen-cooled RF coils and preamplifiers to deliver a sensitivity enhancement over room temperature (RT) probes of a factor of 2 to 3 for X-nuclei from  $^{15}\text{N}$  to  $^{31}\text{P}$ . The Prodigy package is comprised of the probe, a control unit (PCU) and a liquid nitrogen vessel, thus siting is easy and no additional infrastructure is required.



*Figure 3.3: CryoProbe Prodigy with Pump and Control Unit*

Special site planning specifications include:

- $\text{N}_2$  pressure: 6-10 bar (>99% purity), dew point  $-40^\circ\text{C}$ .
- $\text{N}_2$  flow rate: ~40 norm liter/h in steady state.
- Supply voltage 100-120 VAC (+/- 10%) or 220-230 VAC (+/- 10%), 50 or 60 Hz automatic detection.
- 1-Phase 0.5 kW for the PCU.

### 3.5 Other Optional Components



Figure 3.4: Other Options for AVANCE Systems

1.	<b>SampleCase</b> is a 24 sample, random-access, automation system that fits almost all shielded Bruker standard bore magnets.
2.	<b>SampleJet</b> is a robot which has been consciously designed to meet growing demand for simplicity, versatility and higher throughput in NMR sample tube automation.
3.	<b>SampleXpress</b> allows automatic measurement of NMR samples with Bruker NMR spectrometers. SampleXpress is controlled by TopSpin or IconNMR, and is equipped with integrated barcode reader registration, which is under control of SampleTrack.
4.	The <b>Bruker Smart Nitrogen Liquefier (BSNL)</b> is an accessory that uses the extra cooling capacity of the latest generation CryoPlatform to re-condense the evaporating nitrogen gas from the magnet dewar.
5.	The <b>imaging accessory</b> cabinet houses the gradient amplifiers for micro-imaging applications.



## 4 Magnet Access and Rigging

As the magnet is very heavy and fragile, the majority of this chapter focuses on movement of the magnet. The remaining crates (spectrometer, BMPC, etc.) are typically removed from the trucks with forklifts and are positioned in the NMR lab with a pallet jack.



---

### Transport Weight

The transport weight and size of the magnet system, console and their respective crates will affect the choice of equipment required for offloading and movement of the magnet.

---

On the morning of delivery, the magnet, the electronics, all accessories, and the required rigging equipment will arrive on flatbed trucks. A crane or a boom-truck should also be available on site that morning.



---

### Delivery Area

There must be sufficient space in the driveway or parking area for the overhead crane (or boom-truck) and for the delivery truck. There must also be sufficient leveled area for uncrating the magnet and other crates.

---

The crane or boom-truck will be used to unload the magnet crate and place it on a pallet jack located on a slab or dock in front of the access doors/opening to the NMR building. Then, the magnet will be transported to the assembly area in the NMR lab. This process depends on the particularities of the loading dock, the NMR building, and the pathway to the lab. Sometimes, the magnet can be lifted by the crane and lowered directly into the NMR building through a hatch in the roof, or lowered from the side of the building through an air-shaft to a level below ground.

Once the magnet is in place in the NMR room, an A-Frame is used to lift the magnet during the assembly phase.

The remainder of this chapter describes, in detail, how each of these steps are completed.

# Magnet Access and Rigging

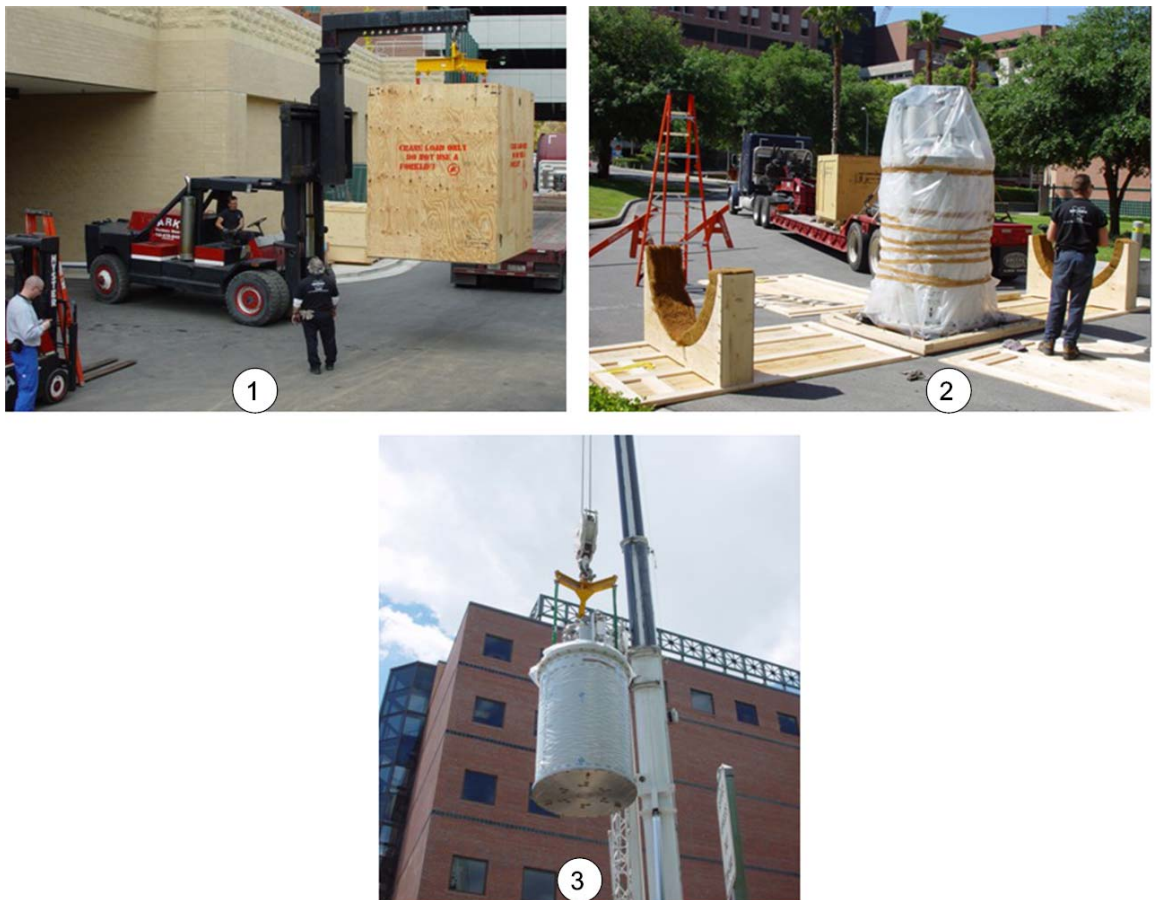

Figure 4.1: Unloading the Magnet

1.	Example of unloading the crated magnet with a boom-truck.
2.	Uncrating the magnet.
3.	Example of lifting the magnet over a building with a crane.

## 4.1 Considerations for Off-loading on Site

Before delivery, the customer must ensure that the site provides adequate access for delivery of the system and magnet. The following factors must be considered:

- An overhead crane or a boom-truck may be used to unload the magnet off the truck and position it correctly for access into the building. The size of the crane will depend on the magnet transport weight and minimum door dimensions, as well as the distance of reach (horizontal and vertical) to the access point into the building (e.g. access door, airway, etc.). This detail is usually attended to by the rigging firm.
- Area available for parking the crane and delivery truck, and also for uncrating the magnet.
- The entry way of the NMR building must be large enough to accommodate the magnet with any rigging equipment necessary. Please refer to the minimum doorway dimensions table.
- The load-bearing capacity of the area for parking the delivery truck and crane, as well as, the area for positioning the magnet prior to the entry into the building would need to be confirmed by the customer as being suitable for all rigging operations. Please refer to the magnet transport weights table.

## 4.2 Considerations for Transport to the NMR Room

Before delivery the customer must ensure that the system and magnet can be transported to the site. The section on Transport Dimensions and Weights [▶25] in this chapter provides the sizes and weights of the crates in which the system are shipped. The following must be considered:

- The access clearance (height and width) and **floor loading capacity** must be checked along the entire route that the magnet will take from the access point into the building to the NMR room. Please refer to the Transport Dimensions and Transport Weights tables.
- Transport will also be affected by any floor irregularities and the presence of door jams and steps. Use masonite **leveling sheets** to traverse floor irregularities such as cracks and door seals.
- **Elevator** capacity and dimensions must also be considered if the magnet must make an elevation change within the building.
- The **turning radius** can also be a factor if, for example, corners must be navigated. It is important to make sure the rigging equipment for magnet assembly (e.g. a long I-beam for the gantry) can be brought into the lab.
- The console and magnet must be moved in an **upright position**.

Refer to the section Rigging Equipment [▶30] for more information.

## 4.3 Transport Dimensions and Weights

### 4.3.1 Magnet Transport Dimensions

System	Crate Size (m)			Magnet Transport Dimensions (m) (for transport to the magnet room)		
	L	D	H	Width Un-crated	Height Un-crated w/o Pallet Jack*	Height Un-crated with Pallet Jack**
200 MHz/154 mm US PLUS LH	1.05	1.26	1.80	0.85	1.53	1.76
300 MHz/54 mm US LH	0.91	0.91	1.59	0.72	1.14	1.37
300 MHz/54 mm Fourier US LH	0.91	0.91	1.59	0.72	1.14	1.37
300 MHz/54 mm Ascend ULH	1.14	0.93	1.98	0.80	1.59	1.82
300 MHz/89 mm Ascend	1.14	0.93	1.98	0.80	1.59	1.82
300 MHz/154 mm US PLUS LH	1.05	1.26	1.80	0.85	1.53	1.76
400 MHz/54 mm Ascend	1.14	0.93	1.98	0.80	1.59	1.82
400 MHz/54 mm Ascend ULH	1.14	0.93	1.98	0.80	1.59	1.82
400 MHz/54 mm Ascend RS	1.34	1.14	1.98	0.85	1.53	1.76
400 MHz/89 mm Ascend	1.14	0.93	1.98	0.70	1.59	1.82

# Magnet Access and Rigging

System	Crate Size (m)			Magnet Transport Dimensions (m) (for transport to the magnet room)		
	L	D	H	Width Un-crated	Height Un-crated w/o Pallet Jack*	Height Un-crated with Pallet Jack**
400 MHz/89 mm Ascend DNP	1.14	0.93	1.98	0.80	1.59	1.82
400 MHz/154 mm US PLUS LH	1.51	1.28	2.12	0.95	1.74	1.97
500 MHz/54 mm Ascend	1.14	0.93	1.98	0.80	1.39	1.62
500 MHz/54 mm Ascend ULH	1.15	1.36	2.02	0.95	1.74	1.97
500 MHz/54 mm Ascend RS	1.34	1.14	1.98	0.85	1.53	1.76
500 MHz/89 mm Ascend	1.14	0.93	1.98	0.80	1.59	1.82
500 MHz/154 mm US PLUS LH	1.51	1.28	2.12	0.95	1.74	1.97
600 MHz/54 mm Ascend	1.14	0.93	1.98	0.80	1.59	1.82
600 MHz/54 mm Ascend ULH	1.51	1.28	2.12	1.10	1.86	2.09
600 MHz/89 mm Ascend	1.15	1.36	2.02	0.95	1.74	1.97
600 MHz/89 mm Ascend DNP	1.15	1.36	2.02	0.95	1.74	1.97
700 MHz/54 mm Ascend	1.15	1.36	2.02	0.95	1.74	1.97
750 MHz/54 mm Ascend	1.51	1.28	2.12	1.10	1.86	2.09
750 MHz/89 mm Ascend	1.75	1.75	2.18	1.37	1.93	2.16

LH = Long Hold, ULH = Ultra Long Hold

\* Measured from magnet bottom plate to helium tower - this is the absolute minimum height!

Note: The heights listed with pallet jack assume that the floor is level, thus the magnet needs only to be jacked up approx. 2 cm for transport. If the floor is uneven, the magnet may need to be jacked up accordingly, which could add as much as 10-15 cm to the transport height.

Table 4.1: Door Dimensions for Magnet Access

## 4.3.2 Magnet Stand Transport Dimensions

Magnet Stand & Accessories	Accessories Crate Size - including stand if applicable (m)		
	L	D	H
200 MHz/154 mm US PLUS LH	1.67	0.88	1.01
300 MHz/54 mm US LH	0.91	0.91	1.59
300 MHz/54 mm Fourier US LH	0.91	0.91	1.59
300 MHz/54 mm Ascend ULH (optional stand)	1.25 (0.97)	0.77 (0.76)	0.60 (1.20)

Magnet Stand & Accessories	Accessories Crate Size - including stand if applicable (m)		
	L	D	H
300 MHz/89 mm Ascend (optional stand)	1.25 (0.97)	0.77 (0.76)	0.60 (1.20)
300 MHz/154 mm US PLUS LH	1.67	0.88	1.01
400 MHz/54 mm Ascend (optional stand)	1.25 (0.97)	0.77 (0.76)	0.60 (1.20)
400 MHz/54 mm Ascend ULH (optional stand)	1.25 (0.97)	0.77 (0.76)	0.60 (1.20)
400 MHz/54 mm Ascend RS	0.97	0.76	1.20
- Cryo cooler box	1.20	0.78	1.14
- Flex line box	1.20	0.80	0.90
400 MHz/89 mm Ascend (optional stand)	1.25 (0.97)	0.77 (0.76)	0.60 (1.20)
400 MHz/89 mm Ascend DNP	0.97	0.76	1.20
400 MHz/154 mm US PLUS LH	1.80	0.93	1.34
500 MHz/54 mm Ascend (optional LC stand)	1.25 (0.97)	0.77 (0.76)	0.60 (1.20)
500 MHz/54 mm Ascend ULH	1.77	0.97	1.11
500 MHz/54 mm Ascend RS	0.97	0.76	1.20
- Cryo cooler box	1.20	0.78	1.14
- Flex line box	1.20	0.80	0.90
500 MHz/89 mm Ascend (optional stand)	1.22 (0.97)	0.42 (0.76)	0.82 (1.20)
500 MHz/154 mm US PLUS LH	1.80	0.93	1.34
600 MHz/54 mm Ascend	0.97	0.76	1.20
600 MHz/54 mm Ascend ULH	1.80	0.93	1.34
600 MHz/89 mm Ascend	1.77	0.97	1.11
600 MHz/89 mm Ascend DNP	1.77	0.97	1.11
700 MHz/54 mm Ascend	1.77	0.97	1.11
750 MHz/54 mm Ascend	1.80	0.93	1.34
750 MHz/89 mm Ascend	1.40	0.83	1.47

LH = Long Hold, ULH = Ultra Long Hold. Pallet is integrated in crate. Add 2-10 cm for pallet jack depending on floor quality. Allow at least 1 cm clearance on the sides and above the crate.

Table 4.2: Door Dimensions for Magnet Stand & Accessories Access

# Magnet Access and Rigging

## 4.3.3 Magnet Transport Weights

Magnet Type	Magnet Weight with Crate (kg)	Magnet Weight w/o Crate & Stand (kg)	Weight of Accessories with Crate (kg)
200 MHz/154 mm US PLUS LH	~710	534	~182
300 MHz/54 mm US LH	~330	204	Shipped with magnet
300 MHz/54 mm Fourier US LH	~330	204	Shipped with magnet
300 MHz/54 mm Ascend ULH (standard/optional stand)	~430	279	~80/160
300 MHz/89 mm Ascend (standard/optional stand)	~465	350	~80/160
300 MHz/154 mm US PLUS LH	~710	534	~182
400 MHz/54 mm Ascend (standard/optional stand)	~415	385	~80/160
400 MHz/54 mm Ascend ULH (standard/optional stand)	~435	405	~80/160
400 MHz/54 mm Ascend RS (stand/cooler/flexline)	~600	~404	~160/20/65
400 MHz/89 mm Ascend (standard/optional stand)	~660	561	~80/160
400 MHz/89 mm Ascend DNP	~660	561	~160
400 MHz/154 mm US PLUS LH	~2300	1500	~270
500 MHz/54 mm Ascend (standard/optional stand)	~670	440	~80/160
500 MHz/54 mm Ascend ULH	~1020	825	~270
500 MHz/54 mm Ascend RS (stand/cooler/flexline)	~670	~503	~160/220/65
500 MHz/89 mm Ascend	~710	578	~160
500 MHz/154 mm US PLUS LH	~2300	1500	~270
600 MHz/54 mm Ascend	~750	619	~176
600 MHz/54 mm Ascend ULH	~1086	963	~345
600 MHz/89 mm Ascend	~1400	1035	~270
600 MHz/89 mm Ascend DNP	~1400	1035	~270
700 MHz/54 mm Ascend	~1400	1035	~270
750 MHz/54 mm Ascend	~1615	~1426	~345
750 MHz/89 mm Ascend	~2730	~2310	~370
LH = Long Hold, ULH = Ultra Long Hold			
The weights of the accessories are approximations. The actual weight may vary depending on the options and accessories that are ordered.			
* For standard stand, weight will vary with optional stands.			

Table 4.3: Magnet Transport Weights

## 4.3.4 Spectrometer and Accessories Transport Dimensions

Spectrometer System (spectrometer crate)	Crate Size (m)			Dimension (m) for Transport to Magnet Room			
	L	D	H	Width Crated*	Width Uncrated*	Height Uncrated w/o Pallet Jack**	Height Uncrated with Pallet Jack**
AVANCE TwoBay	1.54	1.03	1.54	1.05	0.82	1.67	1.46
AVANCE OneBay	1.00	0.92	1.53	1.02	0.71	1.66	1.46
AVANCE MicroBay	1.01	0.83	1.16	0.85	0.71	1.19	1.13
AVANCE NanoBay	1.34	0.75	1.04	0.77	0.45	0.93	0.87

Note: The pallet is now integrated into the crate.

\* Transport width = width indicated + minimum 1cm clearance on each side. These are the widths if the console is inserted lengthways through the entrance.

\*\* Transport height = height indicated + 1 cm clearance on top + minimum 2 cm for pallet jack. The height will vary depending on how high the spectrometer needs to be jacked up to clear any floor irregularities (e.g. cracks).

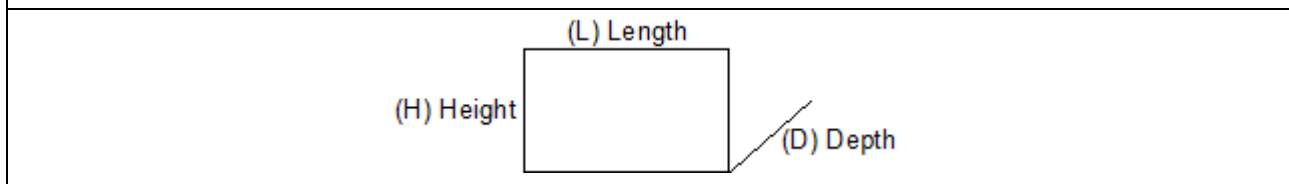

Table 4.4: Door Dimensions for Magnet Room Access: Spectrometers

Accessory	Crate Size (m)		
	L	D	H
CryoProbe (shipped in a CryoCase on a pallet)	1.20	0.80	0.68
CryoCooling Unit	1.66	0.95	0.68
Helium Compressor Water-cooled	0.94	0.84	1.18
Helium Compressor Indoor and Outdoor Unit, with 3 Control Cables (packed in three cartons on one pallet)	0.55	0.55	0.90
SampleXpress	0.96	0.96	0.52
SampleXpress Lite	0.57	0.69	0.42

Note: The accessories are typically transported to the magnet on a pallet jack.

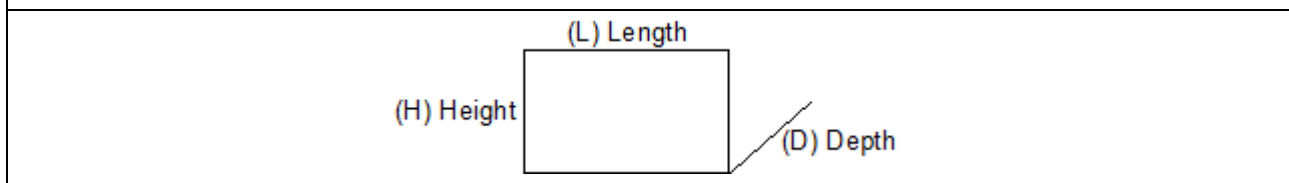

Table 4.5: Crate Dimensions for Accessories

## 4.3.5 Spectrometer and Accessories Weights

Unit	Weight (kg)
AVANCE TwoBay	400*
AVANCE OneBay	210*
AVANCE MicroBay (varies according to options)	approx. 210*
AVANCE NanoBay	120 (without pallet and packing material)
MAS Cabinet	160
Imaging Cabinet	150
HP Cabinet	200
UPS (optional - highly recommended when with CryoProbe system)	260 + 165
SampleXpress	48
SampleXpress Lite	22
Other Sample Changers (depending on model and options)	93-150
LC-NMR Unit, LC-NMR Console (MicroBay), LC-NMR Control Unit (host computer), plus any additional options/accessories	50-250 + weight of MicroBay
Gilson	39.9 + crate and accessories
BCU-I, BCU-II	50, 74
CryoProbe (shipped in a CryoCase on a pallet)	60
CryoCooling Unit	400
UPS for Cryocooling Unit	260 + 165
CryoProbe System He Compressor Water-cooled	160
CryoProbe System He Compressor Air-cooled	280
Emergency Generator (backup) for the He compressor and chiller (highly recommended)	Depends on manufacturer.
Weights include pallets and packing material as required.	
* Weights are for a standard AVANCE™ configuration, actual weights may increase depending on options selected.	

Table 4.6: Transport Weights of NMR Cabinets and Accessories

## 4.4 Rigging Equipment

All rigging equipment must be selected to handle the size and transport weights of the magnet system. For Ultra High Field magnet systems, a crane or a boom-truck is required to remove the magnet from the truck and place it on the dock or slab in front of the access doors to the building. Air skates should be used during transport over floors and through passage ways whenever possible. For lifting during installation, hydraulic lifts are preferred.

Rigging equipment is not included with the NMR system order. The following rigging equipment will be needed for a typical delivery and installation of an NMR magnet system:

- **Crane:** A crane able to handle magnet load is required to lift the magnet off the truck, place it on a flat surface for uncrating, and lift it again and place it on air-skates in front of the access doors, or to place the magnet inside the building (e.g. roof hatch).
- **Leveling Sheets:** Masonite (or other suitable material) sheets may be temporarily required to level the transport route from the access doors to the NMR room, in case of small imperfections.
- **Pallet Jack and/or Fork Lift:** For transporting system accessories to the NMR room.
- **A-Frame or Lifting Hook:** An A-Frame or lifting hook may be used inside the NMR room during assembly phase. When a lifting hook is used, the hook capacity must be certified to hold the required weight of the magnet **before** installation!

### See also

- 📖 [Ceiling Height Requirements \[▶33\]](#)



## 5 Ceiling Height Requirements

The assembly of the magnet system, the magnet energization, and refills with liquid helium require minimum height clearances.

- The ceiling height requirements for the magnet installation and cryogen refills do not need to be met over the entire NMR room. Figure 5.2 illustrates that the height requirements need only be met immediately above the magnet, over an area to allow for assembly of the lifting system (if applicable), and over an area to allow for insertion of the helium transfer line.
- If a soffit is to be used, it is important to consider the area of raised ceiling needed to set-up the lifting system being used to lift the magnet during the assembly phase of the installation. If a transverse I-beam is used in conjunction with the lifting system, this must fit within the confines of the soffit.
- An alternate hydraulic lifting system supporting the magnet at the flanges may be used in rooms with limited ceiling height.
- In lieu of a lifting system, a fixed lifting hook capable of supporting the magnet at a sufficient height can be used to assemble the magnet. However, this option is usually not ideal. See notes below.

### WARNING

#### Fixed Hook

Danger to personnel and equipment due to falling lifting system when using a fixed hook.

- ▶ Removing the heavy hoist directly over the magnet can be very difficult and dangerous for both personnel and the magnet.
  1. It is important to consider how the hoist system and harness will be removed from a fixed lifting hook after the magnet is installed.
  2. Ensure that the hook is certified to hold the weight of the equipment before use.



Figure 5.1: A-Frame Gantry for Lifting the Magnet Inside the Magnet Room

# Ceiling Height Requirements

## 5.1 Helium Transfer Line

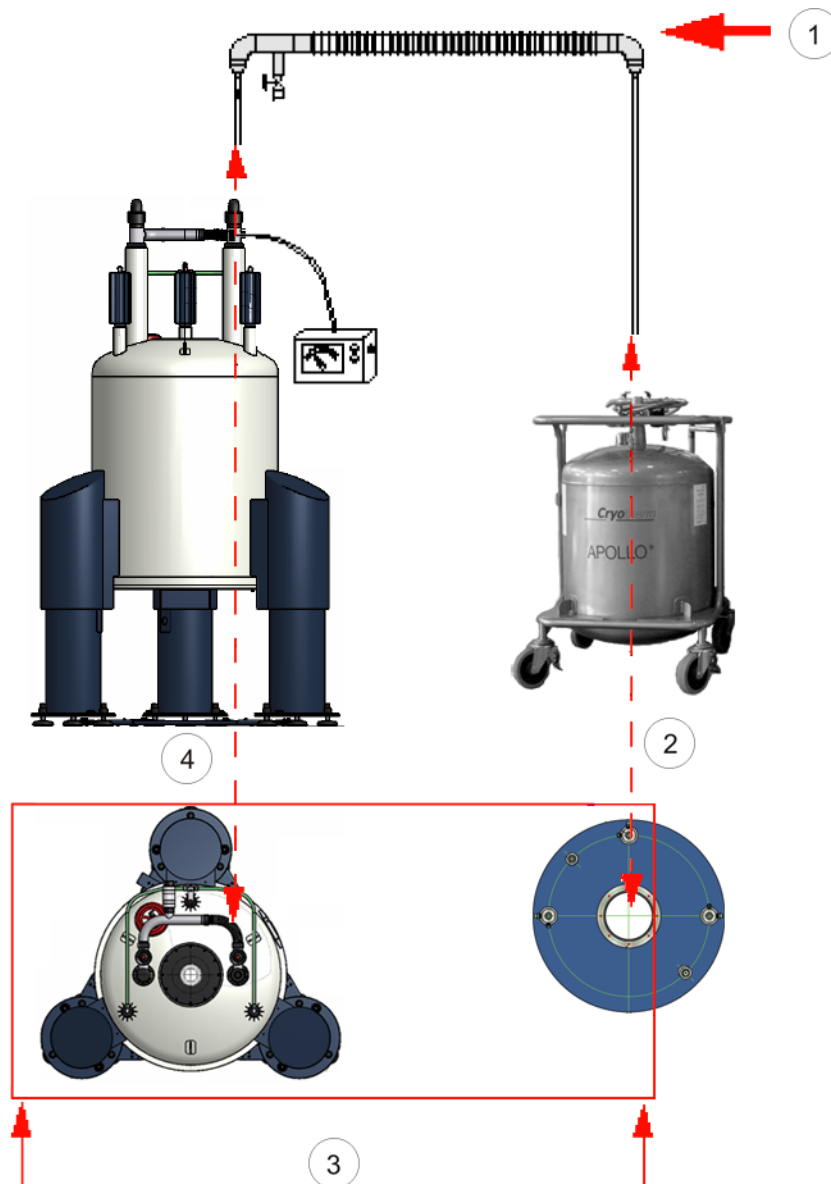

Figure 5.2: Ceiling Height Requirements

1.	Ceiling height must allow for insertion of helium transfer lines.
2.	Liquid helium dewar.
3.	Ceiling height requirements must be met over this area.
4.	Magnet.

# Ceiling Height Requirements

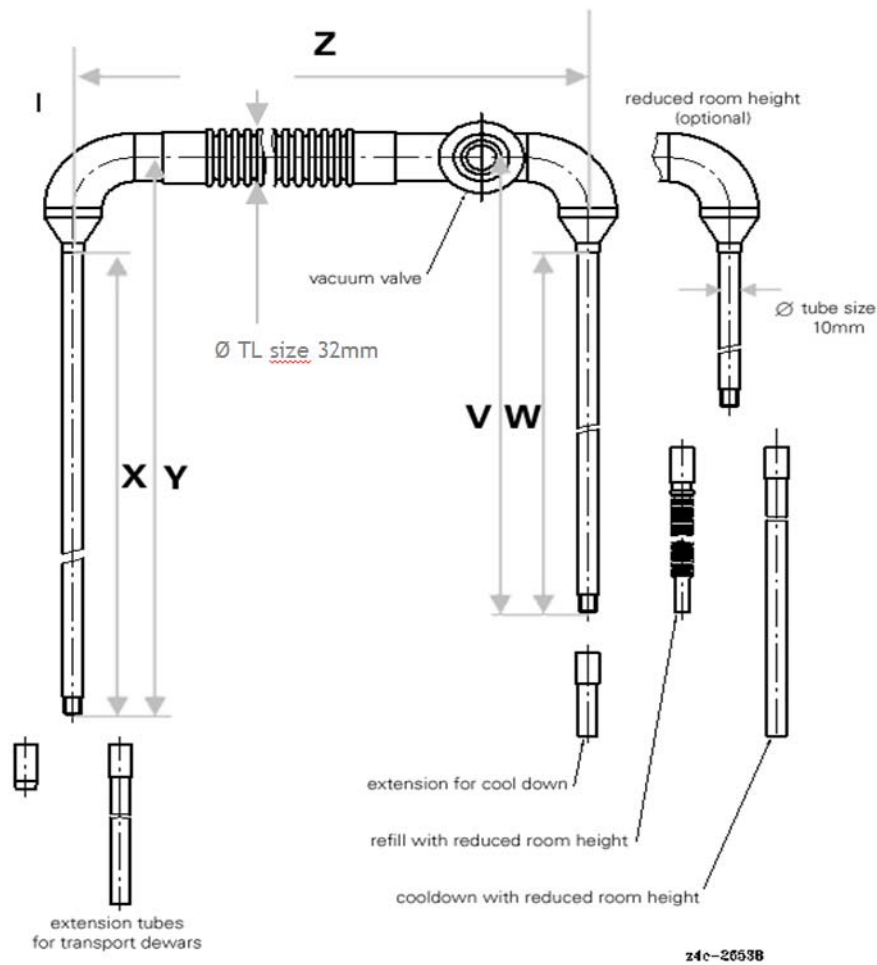

Figure 5.3: Helium Transfer Lines

Refer to the figure above for the following helium transfer line dimensions.

Magnets	Part Nr.	X (mm)	Y (mm)	Z (mm)	V (mm)	W (mm)	Remarks
Ascend / US Plus	53962	1455	1508	2060	708	655	D3XX
	29085	1455	1508	2060	433	380	Reduced Height
	29515	1455	1508	1250	503	450	Reduced Height
D232/D207/D241	O0011	1455	1508	1250	708	655	Standard
D220/D260	29136	1455	1508	2060	638	585	D220/D260

**Note:** When using soffits, sufficient space must be left for the required transfer line length. The magnet may need to be placed off-center within the soffit (as opposed to being centered).

Table 5.1: Helium Transfer Line Dimensions

## 5.2 Minimum Ceiling Height

The minimum ceiling height requirements for operation of each magnet are listed in the following table. Note that the values represent the absolute minimum, an extra 0.3-0.4 m above minimum requirements will make all procedures safer and more convenient.



**Note: The minimum ceiling height requirements for INSTALLATION may be greater than the values in the table below, depending on the options selected.**

The following text explains how the ceiling height requirements in the ceiling height requirements table were either calculated and/or their meaning:

**Minimum Operational Ceiling Height – Helium Transfer Line 29085:**

The minimum operational ceiling height using the helium transfer line 29085 is calculated by adding the height of the shim upper part that has to be inserted into the cryostat, to the height of the top flange of the cryostat.

**Minimum Ceiling Height with Helium Transfer Line 53962:**

The ceiling height using the standard helium transfer line 53962 is calculated by adding the height of the shim upper part that has to be inserted into the cryostat, to the height of the top flange of the cryostat.

**Minimum Ceiling Height for Adapter WB -> SB:**

For all wide bore systems, the minimum ceiling height is calculated to the top of the upper part reduction adapter WB -> SB.

Magnet Type	Minimum Operational Ceiling Height – Helium Transfer Line 29085 (m)	Minimum Ceiling Height with Helium Transfer Line 53962 (m)	Minimum Ceiling Height for Adapter WB -> SB (m)
200 MHz/154 mm US PLUS LH	3.13	3.41	3.07
300 MHz/54 mm US LH	2.42	2.62	---
300 MHz/54 mm Fourier US LH	2.42	2.62	---
300 MHz/54 mm Ascend ULH	2.52	2.80	---
300 MHz/89 mm Ascend	2.87	3.16	---
300 MHz/154 mm US PLUS LH	3.13	3.41	3.07
400 MHz/54 mm Ascend	2.52	2.80	---
400 MHz/54 mm Ascend ULH	2.72	3.00	---
400 MHz/54 mm Ascend RS	2.66	2.94	---
400 MHz/89 mm Ascend	2.86	3.16	---
400 MHz/89 mm Ascend DNP	3.48	3.48	---
400 MHz/154 mm US PLUS LH	3.50	3.78	---
500 MHz/54 mm Ascend	2.52	2.80	---
500 MHz/54 mm Ascend ULH	3.00	3.29	---
500 MHz/54 mm Ascend RS	2.66	2.94	---
500 MHz/89 mm Ascend	3.10	3.39	3.21
500 MHz/154 mm US PLUS LH	3.50	3.78	3.79
600 MHz/54 mm Ascend	2.85	3.14	---

## Ceiling Height Requirements

Magnet Type	Minimum Operational Ceiling Height – Helium Transfer Line 29085 (m)	Minimum Ceiling Height with Helium Transfer Line 53962 (m)	Minimum Ceiling Height for Adapter WB -> SB (m)
600 MHz/54 mm Ascend ULH	3.25	3.53	---
600 MHz/89 mm Ascend	3.25	3.53	3.43
600 MHz/89 mm Ascend DNP	3.25	3.53	3.43
700 MHz/54 mm Ascend	3.00	3.28	---
750 MHz/54 mm Ascend	3.25	3.53	---
750 MHz/89 mm Ascend	3.43	3.96	3.60
LH = Long Hold, ULH = Ultra Long Hold			

Table 5.2: Ceiling Height Requirements



## 6 Magnetic Stray Fields

Magnetic stray fields are three dimensional, and extend further in the vertical direction than in the horizontal direction. A number of studies have been carried out on the long term **effects of magnetic fields on personnel**. As a general rule the working place (e.g. workstation, sample preparation area etc.) must be placed outside the **0.5 mT (5 G)** line. For further information on acceptable magnetic field limits contact your countries health authorities or your area Bruker office.

We strongly recommend using all the mounting devices supplied to change gradient coils or probes. Furthermore, samples must be exchanged by using the sample supports without entering the extremities inside the magnet's bore. These preventive measures minimize doses of magnetic flux and must be applied as a general rule of thumb.

Various devices are affected by the magnet and must be located outside the limits specified in the following section. For comparison the earth's magnetic field is 0.05 mT (0.5 G).

Stray Field Distances	Device	Effects
200 mT (2000 G)	All devices should be outside this line. Refer to current standards on health and safety (e.g. BGV B11 in the European Community) in the workplace for specifications on how long personnel may remain within this area.	
5 mT (50 G)	Magnet power supply, RF power amplifier, Cryo-cooling platform.	Electrical transformers which are a component of many electrical devices may become magnetically saturated in fields above 50 Gauss (5 mT). The safety characteristics of equipment may also be affected.
2 mT (20 G)	Magnetic storage material	The information stored on tapes may be destroyed or corrupted.
1 mT (10 G)	Computers, X-ray tubes, credit cards, bank cards, watches, clocks, cameras, TFT computer monitor.	The magnetically stored information in computers and credit cards may be corrupted in fields greater than 1 mT (10 G). Small mechanical devices such as watches or cameras may be irreparably damaged. (Digital watches may be worn safely).
<b>0.5 mT (5 G)</b>	<b>Pacemakers, Medical Implants Cathode Ray tubes, CryoProbe system.</b>	<b>Magnetic fields greater than 0.5 mT (5 G) will deflect a beam of electrons leading to a distortion of the screen display.</b>
0.1 mT (1 G)	Only very sensitive electronic equipment such as image intensifiers, nuclear cameras and electron microscopes will be affected.	

Table 6.1: Effects of Magnetic Fields on Equipment

The accompanying tables in this chapter display the horizontal stray fields in the radial, direction, as well as, the vertical stray field in the axial direction.

# Magnetic Stray Fields

Please note all measurements in the following tables are in meters!

## 6.1 Horizontal Stray Fields

Magnet Type	5.0 mT (50 G)	3.0 mT (30 G)	1.0 mT (10 G)	0.5 mT (5 G)	0.2 mT (2 G)	0.1 mT (1 G)	0.05 mT(0.5 G)
200 MHz/154 mm US PLUS LH	0.55	0.62	0.78	0.90	1.16	1.47	1.89
300 MHz/54 mm US LH	0.40	0.43	0.51	0.60	0.81	1.05	1.38
300 MHz/54 mm Fourier US LH	0.40	0.43	0.51	0.60	0.81	1.05	1.38
300 MHz/54 mm Ascend ULH	0.40	0.43	0.51	0.60	0.81	1.05	1.38
300 MHz/89 mm Ascend	0.36	0.39	0.48	0.55	0.72	0.91	1.17
300 MHz/154 mm US PLUS LH	0.65	0.72	0.88	1.00	1.29	1.63	2.10
400 MHz/54 mm Ascend	0.38	0.41	0.46	0.50	0.65	0.83	1.08
400 MHz/54 mm Ascend ULH	0.38	0.41	0.46	0.50	0.65	0.83	1.08
400 MHz/54 mm Ascend RS	0.38	0.41	0.46	0.50	0.65	0.83	1.08
400 MHz/89 mm Ascend	0.44	0.47	0.55	0.60	0.69	0.82	1.03
400 MHz/89 mm Ascend DNP	0.54	0.62	0.87	1.10	1.52	1.93	2.45
400 MHz/154 mm US PLUS LH	0.97	1.07	1.30	1.50	2.00	2.55	3.31
500 MHz/54 mm Ascend	0.47	0.50	0.56	0.60	0.74	0.96	1.26
500 MHz/54 mm Ascend ULH	0.47	0.50	0.56	0.60	0.74	0.96	1.26
500 MHz/54 mm Ascend RS	0.47	0.50	0.56	0.60	0.74	0.96	1.26
500 MHz/89 mm Ascend	0.44	0.47	0.55	0.60	0.69	0.82	1.03
500 MHz/154 mm US PLUS LH	0.97	1.07	1.30	1.50	2.00	2.55	3.31
600 MHz/54 mm Ascend	0.52	0.56	0.62	0.70	0.92	1.18	1.55
600 MHz/54 mm Ascend ULH	0.52	0.56	0.62	0.70	0.92	1.18	1.55
600 MHz/89 mm Ascend	0.68	0.74	0.88	1.00	1.30	1.65	2.13
600 MHz/89 mm Ascend DNP	0.68	0.74	0.88	1.00	1.30	1.65	2.13
700 MHz/54 mm Ascend	0.49	0.52	0.65	0.80	1.10	1.42	1.87
750 MHz/54 mm Ascend	0.68	0.74	0.88	1.00	1.30	1.65	2.13
750 MHz/89 mm Ascend	0.95	1.02	1.20	1.40	1.85	2.40	3.10

LH = Long Hold, ULH = Ultra Long Hold  
Distances are measured in **radial** direction from magnetic center.

Table 6.2: Horizontal Stray Fields of Various Magnets

## 6.2 Vertical Stray Fields

Magnet Type	5.0mT (50 G)	3.0mT (30 G)	1.0mT (10 G)	0.5mT (5 G)	0.2mT (2 G)	0.1 mT (1 G)	0.05 mT (0.5 G)
200 MHz/154 mm US PLUS LH	1.10	1.21	1.53	1.80	2.26	2.71	3.30
300 MHz/54 mm US LH	0.57	0.62	0.77	0.90	1.12	1.34	1.63
300 MHz/54 mm Fourier US LH	0.57	0.62	0.77	0.90	1.12	1.34	1.63
300 MHz/54 mm Ascend ULH	0.57	0.62	0.77	0.90	1.12	1.34	1.63
300 MHz/89 mm Ascend	0.68	0.75	0.94	1.10	1.37	1.64	1.98
300 MHz/154 mm US PLUS LH	1.18	1.32	1.69	2.00	2.53	3.06	3.74
400 MHz/54 mm Ascend	0.64	0.70	0.87	1.00	1.24	1.47	1.77
400 MHz/54 mm Ascend ULH	0.64	0.70	0.87	1.00	1.24	1.47	1.77
400 MHz/54 mm Ascend RS	0.64	0.70	0.87	1.00	1.24	1.47	1.77
400 MHz/89 mm Ascend	0.79	0.86	1.05	1.20	1.45	1.70	2.02
400 MHz/89 mm Ascend DNP	0.82	0.92	1.23	1.50	1.99	2.47	3.09
400 MHz/154 mm US PLUS LH	1.48	1.66	2.15	2.55	3.25	3.95	4.85
500 MHz/54 mm Ascend	0.80	0.87	1.06	1.20	1.48	1.75	2.09
500 MHz/54 mm Ascend ULH	0.80	0.87	1.06	1.20	1.48	1.75	2.09
500 MHz/54 mm Ascend RS	0.80	0.87	1.06	1.20	1.48	1.75	2.09
500 MHz/89 mm Ascend	0.79	0.86	1.05	1.20	1.45	1.70	2.02
500 MHz/154 mm US PLUS LH	1.48	1.66	2.15	2.55	3.25	3.95	4.85
600 MHz/54 mm Ascend	0.90	0.99	1.21	1.40	1.71	2.03	2.45
600 MHz/54 mm Ascend ULH	0.90	0.99	1.21	1.40	1.71	2.03	2.45
600 MHz/89 mm Ascend	1.25	1.38	1.72	2.00	2.49	2.98	3.60
600 MHz/89 mm Ascend DNP	1.25	1.38	1.72	2.00	2.49	2.98	3.60
700 MHz/54 mm Ascend	0.99	1.09	1.37	1.60	2.01	2.42	2.95
750 MHz/54 mm Ascend	1.25	1.38	1.72	2.00	2.49	2.98	3.60
750 MHz/89 mm Ascend	1.70	1.90	2.40	2.80	3.50	4.20	5.10
LH = Long Hold, ULH = Ultra Long Hold							
Distances are measured in <b>axial</b> direction from magnetic center.							

Table 6.3: Horizontal Stray Fields of Various Magnets

## 6.3 Stray Field Plots

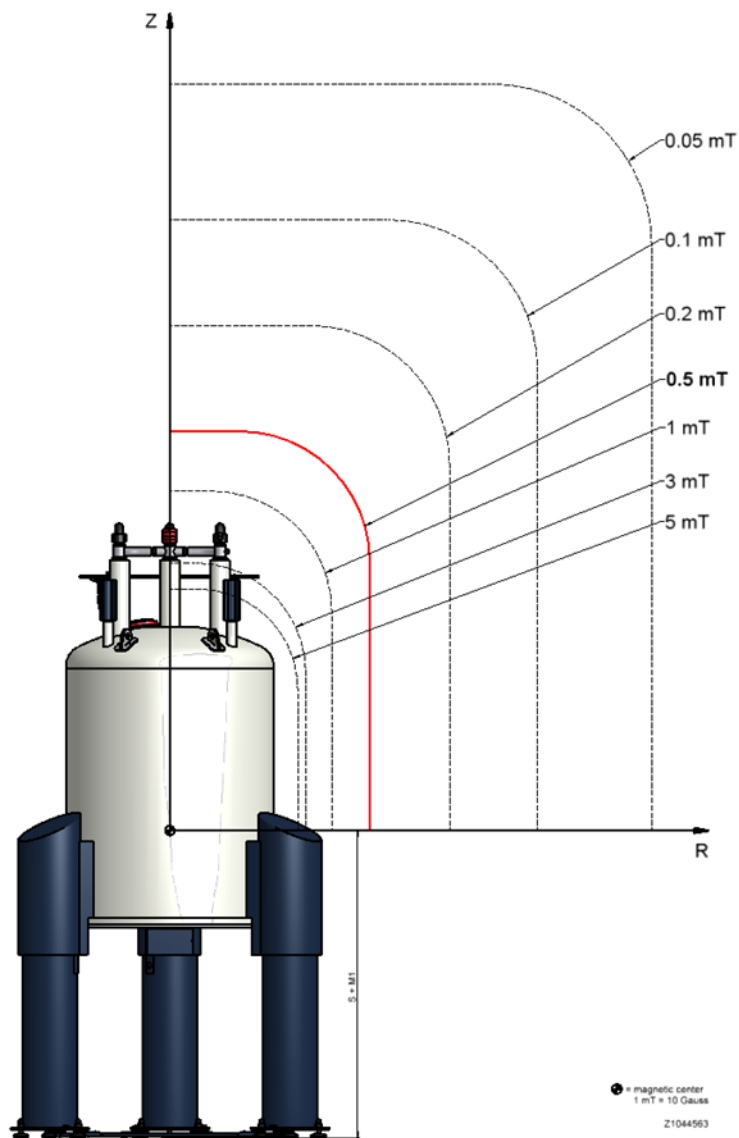

Figure 6.1: Example of a Stray Field Plot 750 MHz/89 mm Ascend

# 7 Environment and Site Survey Measurement

This chapter covers the various site survey topics related to the NMR laboratory. The measurements and associated guidelines include:

- Vibrations
- Magnetic Environment
- Electromagnetic Interference: DC and AC EMF
- RF Interference

---

**Note:**

The results of measurements carried-out during a site survey only reflect the specific conditions that were present during the survey. Although these results are useful as a reference, they would not be conclusive for the after-the-installation system performance if one or more site conditions change. These changes may be related but not limited to sources of vibrations and electromagnetic field and RF interference like electro-mechanical equipment (HVAC, motors, pumps, freezers, etc.), elevators, car/bus/train traffic, power lines, transformers, radio/TV stations and other possible RF sources.

---

## 7.1 Vibrations

---

External vibrations may cause field modulations in the sample cavity. This could result in vibration sidebands, matched NMR signals that appear on either side of a main signal peak. The effect of vibrations on NMR performance will depend on the type of work being carried out, the type of system and the site building materials.

- Ideally the site should be at basement level, or on the ground floor (slab on grade), to minimize building vibrations.
- Possible sources of vibrations are generators, compressors, fans, machinery etc. Vibrations from external sources such as cars, trains, airplanes, and construction sites can also cause problems.
- Measuring the extent of vibrations at the magnet location is a relatively simple matter; if you suspect a problem you should contact your local Bruker office.

### 7.1.1 Vibration Guidelines

---

Measurements of floor accelerations ( $\text{mm}/\text{sec}^2$ ) are required in both vertical and horizontal directions over a minimum frequency range of 0 to 100 Hz. Recording both average and peak-hold values is recommended.

All magnets are equipped with vibration dampers in order to reduce vibrations on the magnet. The isolation performance is given by a transmissibility characteristic for the specific dampers integrated within the magnet. The higher the frequency of floor vibrations, the better the damping (less of the vibration is transmitted).

The acceleration peaks measured directly on the proposed magnet floor must be multiplied by the transmissibility factor of the dampers at the specific frequencies at which these acceleration peaks have been recorded. The results must then be compared to the **maximum 0.1 mm/sec<sup>2</sup>** that can be tolerated at the magnet.

## 7.1.2 Vibration Damping Measures

All Ascend and UltraShield™ Plus magnets are, or optionally can be, equipped with vibration isolation units. Several options are available depending on the magnet model:

- **Elastomer Isolators (EMI)** with vertical damping.
- **Air Spring Isolator (ASI)**
- **Air Spring and Damped Isolators (ADI)** with vertical damping.
- **Air Piston and Damped Isolators (API)** with vertical and horizontal damping.



Figure 7.1: Example of Vibration Damping Isolators

## Environment and Site Survey Measurement

1.	<b>Air Spring and Damped Isolators (ADI)</b> with vertical damping.
2.	<b>Elastomer Isolators (EMI)</b> with vertical damping.
3.	<b>Air Spring Isolator (ASI)</b>
4.	<b>Air Piston and Damped Isolators (API)</b> with vertical and horizontal damping.

Magnet Type	ASI	EMI	ADI	API
200 MHz/154 mm US PLUS LH	---	Standard	Optional (1050 mm)	Optional (1050 mm)
300 MHz/54 mm US LH	Optional AH0060	Standard	Optional AH0061	---
300 MHz/54 mm Fourier US LH	Optional AH0060	Standard	---	---
300 MHz/54 mm Ascend ULH	---	Standard	Optional (570 or 700 mm)	Optional (570 or 700 mm)
300 MHz/89 mm Ascend	---	Standard	Optional (770 or 950 mm)	Optional (770 or 950 mm)
300 MHz/154 mm US PLUS LH	---	Standard	Optional (1050)	Optional (1050)
400 MHz/54 mm Ascend	---	Standard	Optional (570 or 700 mm)	Optional (570 or 700 mm)
400 MHz/54 mm Ascend ULH	---	Standard	Optional (570 or 700 mm)	Optional (570 or 700 mm)
400 MHz/54 mm Ascend RS	---	---	Standard (570 mm), Optional (700 mm)	Optional (570 or 700 mm)
400 MHz/89 mm Ascend	---	Standard	Optional (770 or 950 mm)	Optional (770 or 950 mm)
400 MHz/89 mm Ascend DNP	---	---	Standard (950 mm)	Optional (950 mm)
400 MHz/154 mm US PLUS LH	---	---	Standard (1050 mm)	Optional (1050 mm)
500 MHz/54 mm Ascend	---	Standard	Optional (570 or 700 mm)	Optional (570 or 700 mm)
500 MHz/54 mm Ascend ULH	---	---	Standard (700 mm)	Optional (700 mm)
500 MHz/54 mm Ascend RS	---	---	Standard (570 mm), Optional (700 mm)	Optional (570 or 700 mm)
500 MHz/89 mm Ascend	---	---	Standard (950 mm)	Optional (950 mm)
500 MHz/154 mm US PLUS LH	---	---	Standard (1050 mm)	Optional (1050 mm)
600 MHz/54 mm Ascend	---	---	Standard (700 mm)	Optional (700 mm)
600 MHz/54 mm Ascend ULH	---	---	Standard (800 mm), Optional (950 mm)	Optional (800 or 950 mm)
600 MHz/89 mm Ascend	---	---	Standard (880 mm)	Optional (880 mm)
600 MHz/89 mm Ascend DNP	---	---	Standard (880 mm)	Optional (880 mm)
700 MHz/54 mm Ascend	---	---	---	Standard (700 mm), Optional (880 or 950 mm)

Magnet Type	ASI	EMI	ADI	API
750 MHz/54 mm Ascend	---	---	---	Standard (800 mm), Optional (950 mm)
750 MHz/89 mm Ascend	---	---	Standard (950 mm), Optional (1050 mm)	Optional (950 or 1050 mm)
LH = Long Hold, ULH = Ultra Long Hold				

Table 7.1: Vibration Damping Options

## 7.2 Magnetic Environment

The presence of any ferromagnetic materials in the immediate vicinity of the magnet will decrease the magnets homogeneity and may degrade overall performance. Although minimum requirements for routine NMR are not stringent, the magnetic environment must be optimized if more sophisticated experiments are being carried out. Usually, the effect of metal pipes, radiators, and other such objects can be “shimmed out”, but whenever possible, this should be avoided.

To assist in site planning two sets of guidelines are given below: “**minimum requirements**” and “**acceptable environment**”.

### Note:



If minimum requirements can not be met, the customer should consider a different site because NMR performance is likely to be reduced. By acceptable environment we mean an environment with which most customer sites comply. This is a situation which is desirable, though not always achievable.

### 7.2.1 Minimum Requirements

Minimum requirements **must be met** or a different site should be considered because NMR performance is likely to be reduced.

#### 7.2.1.1 Static Iron Distribution

There should not be any present within the 0.5 mT (5 G) region. You should consider removing iron piping that is likely to lie within such fields prior to installation. If the magnet must be located close to iron or steel support beams a proper alignment is important. Support beams should pass through or be symmetric to the magnet axis.

The 0.5 mT (5 G) limit is suitable for a mass of up to 200 kg. For greater masses the limiting area must be extended accordingly. (The presence of static magnetic material close to the magnet presupposes that these masses are firmly secured e.g. radiators, pipes).

#### 7.2.1.2 Moveable Magnetic Material

For all magnet systems, no moveable masses should be located within the 0.5 mT (5 G) region. Potential sources of moving iron are metal doors, drawers, tables chairs etc. For larger masses (> 200 kg), distorting effects may be experienced at fields as low as 0.1 mT (1 G). For high precision work (e.g. NOE difference experiments) extending the region for no moveable magnetic

material to 0.05 mT (0.5 G) may be justified. The table in section Moving Objects [ 48] serves as a guideline for moveable magnetic material.

## 7.2.2 Acceptable Environment

By „acceptable environment“ we mean an environment with which most customer sites comply. This is a situation which is desirable, though not always achievable.

### 7.2.2.1 Static Objects

The next table gives a list of common sources of magnetic interference. These items should be located according to the recommendations below. It must be emphasized however, that such recommendations represent a situation that may not be achievable. Please consult with Bruker for possible solutions if one or more of these recommendations cannot be satisfied.

#### 7.2.2.1.1 Recommendations for Static Magnetic Objects

Object	Actual distance from magnetic center (m): Ascend Magnets	Actual distance from magnetic center (m): UltraShield PLUS Magnets
Iron or steel beams	3	3
Steel reinforced walls	3	3
Radiators, plumbing pipes	3	3
Metal table, metal door	3	3
Filing cabinet, steel cabinet	3	3
Massive objects, e.g. boiler	3	3

Table 7.2: Recommendations for Static Magnetic Objects

## 7.2.2.2 Moving Objects

The table below serves as a guideline for moveable magnetic material.

Note that D.C. operated elevators, trains, and trams may cause disturbances over much larger distances (see Guidelines for DC Interference [▶ 49]). In addition, these may also cause vibrational disturbances.

### 7.2.2.2.1 Recommendations for Movable Magnetic Objects

Object	Actual distance from magnetic center (m): Ascend Magnets	Actual distance from magnetic center (m): UltraShield PLUS Magnets
Steel cabinet doors	4	4
Large metal door, hand trolley	4	4
Elevators*	6	6
Trucks, cars, fork-lifts	9	9
Trains, subways, trams	30	30

Table 7.3: Recommendations for Moveable Magnetic Objects

## 7.3 Electromagnetic Interference

Possible sources of interference are power lines which may carry fluctuating loads, heavy duty transformers, large electric motors, air conditioning systems, power transformers, etc.

The fluctuating electromagnetic fields arising from such devices can interfere with the magnet homogeneity. Of particular concern are sudden changes in load as may be produced by elevators, trams, subways etc. Some laboratory equipment such as mass spectrometers and centrifuges will also give rise to fluctuating fields. Other sources of interference include radio and television stations, satellites and other RF transmitters that may operate in the vicinity of NMR frequencies of interest.

**If you suspect that you have a source of interference located near the proposed magnet site then you should contact Bruker Biospin for a site survey.**

### 7.3.1 Types of EMF Interference

- DC Interference
- 50/60 Hz Interference
- RF Interference

### 7.3.2 DC EMF Interference

DC interference generally comes from devices operated on DC, such as elevators, trains, subways, trams, etc. The locations of both the device and its power supply & lines relative to the proposed NMR site are essential to the amplitude and orientation of DC fields and how they may interfere with the NMR system. DC feeder lines are just as disturbing as a subway, and they do not run necessarily parallel to the track.

## 7.3.2.1 Measuring DC Fluctuating Fields

DC EMF measurements should be conducted using a **fluxgate magnetometer**. The fluxgate sensor is capable of accurately measuring magnetic field changes below 1mG. The sensor is connected to a magnetometer, and the voltage output from the meter is then converted into digital form. The magnetic field is recorded and plotted on a computer display in real time.

## 7.3.2.2 Guidelines for DC Interference

When determining the effect of fluctuating magnetic fields, two parameters are important: the size of the fluctuation and the rate of change.

- Field changes of up to 5 mG, regardless of the rate of change, are generally considered harmless for standard NMR work.
- Field changes larger than 5 mG will be compensated by the digital NMR lock, as long as their rate of change is less than 10 mG/sec.
- Field changes faster than 10 mG/sec need to be addressed in more detail along with the types of NMR experiments to be performed, in order to better assess whether the NMR performance will be affected. **Please consult with Bruker to assess the level of interference and explore solutions.**

The following table lists the minimum distances between the source of interference and the magnet center.

Source of Interference	Recommended Minimum Distance from Magnet Center (m)
DC trains, subways, trams*	100
DC elevators*	9
Mass spectrometer (slow ramp)	12**
Mass spectrometer (sudden fly back)	30**
* Elevators, trains, subways, and trams are also a source of vibrational interference.	
** Mass spectrometer specifications depend on the manufacturer.	

Table 7.4: Minimum Distances from Sources of DC EMF Interference

## 7.3.2.3 Reducing DC Interference

The amplitude of the “full external perturbation” (peak-to-peak) is measured with the fluxgate magnetometer at the proposed magnet location but in the absence of magnet. There are two levels of compensation against these external DC field perturbations:

1. First, the magnet screens itself against external perturbations, hence only a fraction of the full perturbation is left at the magnet center. We call this residual field perturbation after magnet screening. It’s value is relevant to NMR experiments without lock, relevant to many solids experiments and high resolution experiments using gradients which require lock hold.
2. Second, the advanced digital NMR lock further minimizes the interference after magnet screening. The digital lock is less susceptible to field perturbations than the older analog lock. The final response may depend on the lock substance and concentration.

## 7.3.3 16-2/3 Hz and 50/60 Hz EMF Interference

---

Interference from 16-2/3 Hz generally comes from modern electric trains and/or streetcars that run at 16-2/3 Hz. Likewise, the 50/60 Hz interference generally comes from electrical wiring, transformers and fluorescent lights located in the vicinity of the magnet as well as near the NMR cabinet and workstation. The magnetic field further modulates this interference, increasing the likelihood of disturbances.

### 7.3.3.1 Measuring 16-2/3 Hz and 50/60 Hz Fluctuating Fields

---

The amplitude and orientation of the 16-2/3 Hz and 50/60 Hz fluctuating fields should be mapped within the proposed NMR room with power lines active using a hand-held meter. Specific locations that must be checked carefully include:

- Magnet area.
- Console area.
- Along the wall inside the NMR room at 5 cm (~2") from wall, and 3.8 cm (4") from wall.
- Approximately 5 cm (~2") below the existing lights in the room.
- Near the main outlets 230V (USA - 208V) locations in the room.

### 7.3.3.2 Guidelines for 16-2/3 Hz and 50/60 Hz Interference

---

The amplitude at which interference is likely is ~ **5 mG (0.0005 mT) RMS**. Since this amplitude is based on laboratory tests, ideal values should be well below 2.5 mG (0.00025 mT) RMS.

The magnet should not be placed within a 6 m (20') radius of a normally-sized transformer. If there is a large transformer adjacent to the proposed magnet location, measurements will be required to determine if the transformer will adversely affect NMR spectra.

The magnet should not be placed directly under fluorescent lights. Fluorescent lighting may cause interference, and may switch off temporarily during a quench.

### 7.3.3.3 Reducing 16-2/3 Hz and 50/60 Hz Interference

---

The general goal of reducing 16-2/3 and 50/60 Hz interference is to shield the source of the interference from the magnet system. Soft iron has been found to be effective in reflecting this interference, and thus providing an effective shield for the magnet. Bruker provides planning for shielding using various metals and shielding techniques, please contact your Bruker office for further information.

## 7.3.4 RF Interference

---

The NMR instrument is effectively a very sensitive radio frequency receiver. Possible sources of interference are local radio or television broadcasts, low Earth orbit satellite systems, and signals emitted by personal paging systems. Of particular concern will be interference at frequencies at which NMR experiments are carried out. Although the interference effects will depend greatly on the strength of the transmitter, as a rule of thumb only broadcasting transmitters located within a radius of approximately 5 kilometers (3 miles) are likely sources of interference.

RF interference may also occur between two or more spectrometers located in close proximity and operating at the same nominal 1H resonance frequency.

## 7.3.4.1 Measuring RF Fluctuating Fields

Radio Frequency Interference measurements should be conducted using a spectrum analyzer. The analysis should be done for the resonance frequency of each of the nuclei of interest (proportional to the 1H resonance frequency of the spectrometer). The minimum frequency sweep is 400 kHz. Any peaks with RF fields above -80 dBm should be recorded, as well as any broad frequency ranges with any level of RF signals.

Below is a list of the most common studied nuclei at the corresponding frequencies for the NMR systems discussed in this manual.

### See also

 Reducing RF Interference [▶51]

## 7.3.4.2 Most Commonly Studied Nuclei

Nuclei	NMR Frequency (MHz)						
	200	300	400	500	600	700	750
1H	200.000	300.000	400.000	500.000	600.000	700.000	750.131
2H	30.701	46.072	61.422	76.773	92.124	107.474	115.151
11B	64.167	96.294	128.378	160.462	192.546	224.630	240.697
13C	50.288	75.468	100.613	125.758	150.903	176.048	188.631
15N	20.265	30.423	40.560	50.697	60.834	70.971	76.145
19F	188.154	282.404	376.498	470.592	564.686	658.780	705.948
27Al	52.114	78.204	104.261	130.318	156.375	182.432	195.603
29Si	39.730	59.627	79.495	99.362	119.229	139.096	149.202
31P	80.961	121.495	161.976	202.456	242.937	283.418	303.963

Table 7.5: List of Most Commonly Studied Nuclei and Corresponding Resonance Frequencies

## 7.3.4.3 Guidelines for RF Interference

As a general guideline the level of any RF interference should be less than an electrical field strength of -65 dBm at the side of the magnet. However, past experience has shown that broadband RF fields having smaller intensity (about -80dBm) may interfere with the NMR experiments. Therefore, it is important to make a note of any measurements exceeding -80 dBm.

## 7.3.4.4 Reducing RF Interference

Screening a site for possible RF Interference is complicated and expensive. Shielding of the NMR room with a Faraday cage is a possible solution, though having to take such measures is quite rare.

When designing and manufacturing the Bruker spectrometers, care is taken to provide adequate shielding and the instruments rarely suffer from interference in normal RF environments. Furthermore, the advanced BSMS digital lock system - included with all Bruker AVANCE spectrometers - allows a shift in the 2H lock frequency with certain limits. This may allow enough variation in the absolute magnet field strength to shift the NMR signal away from that of local broadcasting frequencies.

RF interference may occur between two or more spectrometers located in close proximity and operating at the same nominal  $^1\text{H}$  resonance frequency. These problems can be avoided by energizing the different magnets at slightly different fields, such that their operational frequencies are separated by  $\sim 200$  kHz of the nominal  $^1\text{H}$  resonance frequency.

# 8 Utility Requirements

## 8.1 Electrical Power Requirements

---

When planning the electrical power requirements of your site make provision for extra equipment which you may install, e.g. Personal Computers, workstations, air conditioning systems, etc.

Each AVANCE™ cabinet (except NanoBay) comes supplied with four spare electrical outlets (230V/10A) which can be used to power standard ancillary equipment. Two outlets are designed to power the NMR Workstation and Imaging cabinet (optional). This leaves two spare outlets for accessories such as the Sample Changers etc. The table in this section lists the power requirements of other equipment which, because of their large power consumption, require power sources separate to that of the AVANCE™ cabinet.

### Other Power Requirement Considerations

- For installation of the AVANCE system a 230V / 16A outlet is needed for the turbo-pumps, as well as an additional 230V / 16A outlet for the magnet power supply (during installation and service).
- A TwoBay with Solid Accessory 600/700 MHz can be approximated to a standard TwoBay plus High Power cabinet and so the total power requirements is 9.6 kW.
- The power requirements for the CP-MAS will depend on the amplifiers that are used. The control unit itself will not use more than 100W.
- If line voltage fluctuations exceed -5% to +10% a voltage stabilizer must be used. The lifetime of the various electrical components in the spectrometer will also be lengthened when a voltage stabilizer is used. Contact your local Bruker BioSpin office for more information on voltage stabilizers.
- Where total interruption of power occurs frequently, you should consider installing a UPS (Uninterruptable Power Supply) possibly linked to an automatic cut-in generator. This is particularly advisable when long-time experiments are to be run.
- The power supply to the spectrometer must be "clean" (no spikes), i.e. it must not share with air conditioners, compressors, etc.
- All grounding for mains in the lab must be connected together to avoid differences in earth potential.

## Utility Requirements

System and Amplifiers	Mains Supply	Power Consumption (kW)*	No. of Spare Electrical Outlets	Length of Mains Cable (m)
TwoBay with BLARH100 + BLAX300	230V 50/60 Hz / 16A single phase; or 208V 60 Hz / 20A single phase in USA	2.6	4 (230V max. 10 amp.)	5.5
TwoBay with BLAXH300/50	230V 50/60 Hz / 16A single phase; or 208V 60 Hz / 20A single phase in USA	2.2 9.6	4 (230V max. 10 amp.)	5.5
TwoBay optimized for solids 300 to 700 MHz	230V 50/60 Hz / 32A single phase or 400V 50/60 Hz / 16A triple phase; or 208V 60 Hz / 32A single phase in USA	5.0	4 (230V max. 10 amp.)	5.5
OneBay with BLAXH100/50	230V 50/60 Hz / 16A single phase; or 208V 60 Hz / 20A single phase in USA	1.6 2.2	4 (230V max. 10 amp.)	5.5
MicroBay with BLA2BB	230V 50/60 Hz / 16A single phase; or 208V 60 Hz / 20A single phase in USA	1.2 1.6	4 (230V max. 10 amp.)	5.5
NanoBay	230V 50/60 Hz / 16A single phase; or 208V 60 Hz / 20A single phase in USA	1.0	---	5.5
Imaging Cabinet	230V 50/60 Hz / 32A single phase or 400V 50/60 Hz / 16A triple phase; or 208V 60 Hz / 30A single phase in USA	2.4	---	---
Bayvoltex Chiller for MicroImaging Systems	230V 50/60 Hz / 16A single phase or 208V 60 Hz / 20A single phase in USA	approx. 0.45 kW	---	---
BCU-I/BCU-II	230V 50/60 Hz / 16A single phase or 208V 60 Hz / 20A single phase in USA (power for BCU-II must come from separate outlet).	0.45 kW (BCU-I) 2.3 kW (BCU-II)	---	---
UPS for AVANCE Spectrometer Cabinet	UPS requirements: At least 2,6 kW for the spectrometer cabinet (depends on configuration). The battery time must be selected according to the maximum duration anticipated for a power failure.			
* Includes the NMR workstation and computer monitor, and was measured using 2 amplifiers operating at maximum output in CW mode. For systems fitted with additional amplifiers allow 300W for each additional amplifier.				

Table 8.1: Requirements of Basic System (2 Channels)

## 8.1.1 CryoProbe Utility Requirements

<b>CryoProbe:</b>			
	None.		
<b>CryoPlatform:</b>	<b>CryoCooling Unit</b>		
		Electrical service:	1 phase, 230 VAC, 60 Hz, not supplied from spectrometer
		Heat generation:	800 W peak, 500 W average
		Air:	> 4.5 Bar independent of spectrometer air, dedicated line suggested
		UPS (optional):	500 Watts
	<b>Helium Compressor (water cooled)*</b>		
		Electrical service:	3 phase, 208 VAC, 60 Hz, 25 A, starting current 110 A
		Heat generation:	8.5 kW peak, 7.5 kW average
		Water:	Minimum flow 420 l/h, forward temperature < 25°C cooling power 10 kW, water quality pH 6.5-8.2, hardness (mg[CaCO <sub>3</sub> ]/l) < 200, Molybdate-reactive silicate (mg/l) < 50 suspended matter (mg/l) < 10). Caution: Do not use demineralized or deionized water.
	<b>Helium Compressor (indoor air cooled)**</b>		
		Electrical service:	3 phase, 208 VAC, 60 Hz, 25 A, starting current 110 A
		Heat generation:	8.5 kW peak, 7.5 kW average
	<b>Helium Compressor (outdoor air cooled)**</b>		
		Electrical service:	3 phase, 208 VAC, 60 Hz, 35 A, starting current 110 A
		Heat generation:	8.5 kW peak, 7.5 kW average
<b>Helium Cylinder</b>			
	Research grade 6.0:	99.9999% pure, batch tested ok	
<b>Console</b>	UPS (recommended):	>2.6 KW (dependent on configuration)	
	Additional requirements are described in detail in the CryoProbe Site Planning Guide. If you require additional information please e-mail your request to sales@bruker-biospin.com.		
<p>* The compressor generates heat and requires a cooling mechanism. The water cooled compressor can be cooled with an appropriate water chiller. See Bruker BioSpin's guide to 'Cooling the CryoPlatform' Helium Compressor' for recommendations about water or process chillers.</p> <p>** The compressor generates heat and requires a cooling mechanism. The air-cooled compressor must be sited outdoors or where sufficient air-conditioning capacity or appropriate ventilation can be provided. It should not be in the same room as the NMR spectrometer.</p>			

Table 8.2: CryoProbe System Utility Requirements

## 8.2 Telecommunication

---

Please refer to the AVANCE NMR layout in chapter Floor Plan [▶69]. The following ports are required:

- Telephone/data ports behind the workstation.
- Dedicated analog modem (telefax) port behind the monitoring unit (BMPC).

## 8.3 Compressed Gas

---

### 8.3.1 General Requirements

---

**Compressed gas line:** The standard AVANCE system requires one compressed gas line with two regulated outputs. Two additional secondary connectors are preferred.

**Regulators:** Watts Regulator R119-03C (Watts Fluid Air Company), pressure range 0-8.6 bar (0 - 125 psi), with gage head included.

- Compressed nitrogen gas needed for temperature control with VT experiments in order to achieve optimal NMR performance. For example, the BCU-I cooling unit requires a dew point of  $-51^{\circ}\text{C}$  ( $-60^{\circ}\text{F}$ ) for the compressed gas.
- Compressed air or nitrogen gas for spinning.
- Compressed air or nitrogen gas for sample ejection, and for the magnet's vibration isolation units.
- Compressed air or nitrogen gas for the optional CryoProbe system.

### 8.3.2 Compressed Gas Options

---

#### Option 1 (preferred for 500 MHz and up):

Nitrogen gas only: 57 l/min. (2 scfm) for non-MAS experiments, or 227 l/min. (8 scfm) for MAS experiments. The pressure should be 6-8 bar (80-120 psi).

#### Option 2 (good for 500 MHz and up where spinning is common):

Nitrogen gas for VT work and sample spinning (cannot be provided by a N2 separator).

Compressed air: 57 l/min. (2 scfm) for lifting pneumatic dampers.

N2 gas: 57 l/min. (2 scfm) for spinning and VT work.

#### Option 3 (good for 500 MHz and up where spinning is not common):

Nitrogen gas for VT work (can be provided by a N2 separator):  $\sim 28$  l/min. (1 scfm).

Compressed air: 57 l/min. (2 scfm) for lifting, spinning, and pneumatic dampers.

#### Option 4 (good for lower-field instruments: 200-400 MHz)

Compressed air for lifting, spinning, pneumatic dampers and VT work: 57 l/min. (2 scfm) at 6-8 bar (80-120 psi.).

**Note:** A nitrogen separator (supplied by Bruker) can be built into the AVANCE cabinet as an available solution for option 3. This will produce the nitrogen gas required for VT work. However, this is not suitable for larger flow rates required by MAS experiments.

The nitrogen separator is suitable for use with the BCU-I cooling unit. However the nitrogen output from the separator is not pure enough and this unit should not be used with a N2 exchanger or BCU-II cooling unit for low temperature work.

## 8.3.3 Gas Requirements For Accessories

- If use of a Bruker sample changer in high throughput mode is planned, a secondary regulator, T-split from the supply line, is recommended.
- For MAS (Double Bearing) a second regulator is mandatory. Make sure the supply line cross-section is sufficient to deliver the necessary volume at the required pressure.
- If a CryoCooling unit is to be installed, a secondary regulator, T-split from the supply line is recommended.
- If the Emergency Sample Protection Device is to be used in conjunction with the CryoProbe system, a cylinder of air or nitrogen gas is required.

### 8.3.3.1 Compressed Gas Requirements

System	Operating Pressure	Average Consumption	Recommended Minimum Gas Supply**
AVANCE	6-8 bar (80-120 psi)	45 l/min. (~1.6 cfm)	57 l/min. (~2 cfm)
AVANCE + SampleJet	6-8 bar (80-120 psi)	100 l/min. (~3.6 cfm)	100 l/min. (~3.6 cfm)
AVANCE + SampleXpress	4-7 bar (58-102 psi)	~15 l/min. (~0.6 cfm)	100 l/min. (~3.6 cfm)
AVANCE + SampleXpress Lite	4-7 bar (58-102 psi)	~15 l/min. (~0.6 cfm)	100 l/min. (~3.6 cfm)
AVANCE + MAS (DB*)	6-8 bar (80-120 psi)	220 l/min. (~8 cfm)	300 l/min. (~11 cfm)
AVANCE + SampleCase	5 bar (73 psi)	100 l/min. (~3.6 cfm)	100 l/min. (~3.6 cfm)
AVANCE + SampleMail	5-7 bar (73-102 psi)	100 l/min. (~3.6 cfm)	100 l/min. (~3.6 cfm)
AVANCE + Gilson	6-8 bar (80-120 psi)	46 l/min. (~1.7 cfm)	57 l/min. (~2 cfm)
Vibration Isolation Units	6-8 bar (80-120 psi)	3 l/min. (~0.2 cfm)	3 l/min. (~0.2 cfm)

Note: 1 bar =  $10^5$  Pascal (Pa).

\* DB= Double Bearing

\*\* This is the actual consumption and minimum needed at the instrument input after the N2 supply (either a bulk tank, or a N2 separator).

For non-MAS work, if an air-compressor and N2 separator are used, the flow requirements are 50% higher, i.e. 3 cfm. It is recommended to use a dual unit oil-less air-compressor rated at min. double capacity of the specified requirement. Please refer to the next section on air compressors.

Table 8.3: Compressed Gas Requirements

## 8.3.4 Compressed Gas Specifications

**Oil Content:**

< 0.005 ppm (0.005 mg/m<sup>3</sup>)

### Water Content:

For the BCU-I cooling unit the compressed gas should have a dew point of -51°C (-60°F). For the BCU-II cooling unit, the dew point requirement is -100°C (-148°F).

For room temperature work and higher: Dew point of < 4°C (39.2°F).

For low temperature work: The dew point must be at least 20°C (68°F) below the operating temperature.

If a cooling unit is used, then the dew point of the compressed nitrogen should be at least 10°C (50°F) below the temperature at the heat exchanger output.

### Solid Impurities:

Use 5 micron filters for high resolution NMR. For MAS probes use 1 micron filters. The filters should retain a minimum of 99.99% of the specified particles.

## 8.3.5 Compressed Air System

When designing a suitable compressed air system the following points must be taken into consideration:

- To prevent magnetic impurities from entering the magnet use only copper or stainless steel lines. Do not use iron or steel pipes. Plastic piping is unsuitable where very low dew points are required. Water vapor in the air will permeate plastic piping limiting minimum dew points to typically -25°C.
- To avoid surges in the air pressure (e.g. during sample lift) install a container of 10-20 liters in the air supply line to act as a buffer. Locate the buffer after the dryers in the supply line. **Buffer containers** must meet the appropriate safety requirements. They must have a working pressure of 16 bar and be proofed up to 30 bar. Use tanks which are internally coated with water and acid resistant material. This will prevent corrosion from impurities such as SO<sub>2</sub>.

The three major components in a suitable compressed air supply line include the compressor, dryer and appropriate filters:

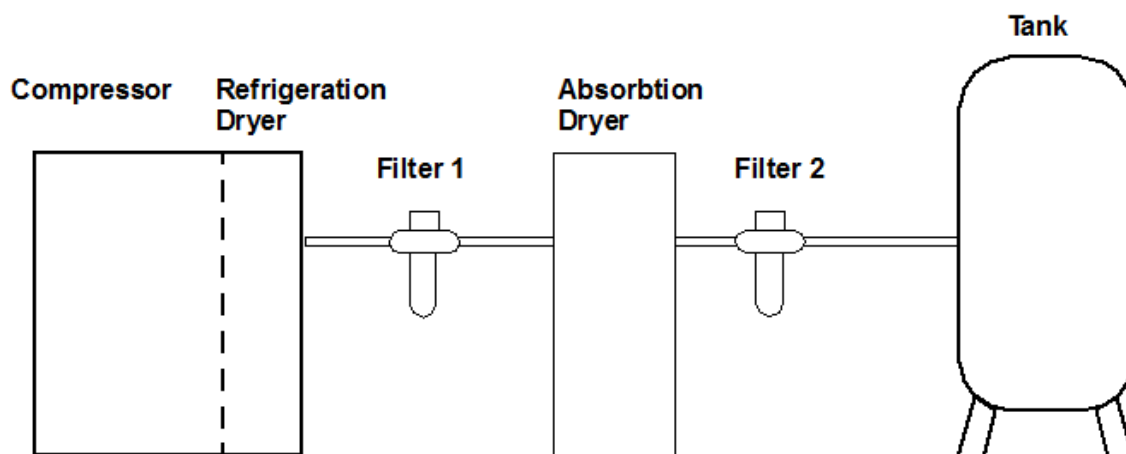

Figure 8.1: Example of a Typical Dryer/Filter System Setup

Filter 1:	General purpose liquid and dust removal filter (0.1 mg/m <sup>3</sup> - 0.1 ppm, 1 micron).
Filter 2:	High-efficiency dust, liquid and aerosol filter (0.1 mg/m <sup>3</sup> - 0.01 ppm, 1 micron).

When using a dryer/filter system setup, the following questions should be addressed:

- Pressure loss in piping?
- Efficiency loss in dryer?
- Pressure loss in filter?
- What is the required pressure?
- What is the required flow rate?

### 8.3.5.1 Air Compressors

---

When choosing an air compressor the following points should be considered:

- Ideally the compressor should be installed in a **dust free**, cool (use air conditioning as required) and dry place.
- The compressor must be **oil-free**. This can be achieved by using membrane or Teflon coated piston and scroll compressors. The compressor should be fitted with a fine dust inlet filter.
- The compressor must be capable of delivering the required flow rate and pressure suited to your particular system (see Compressed Gas Requirements [▶ 57]). Generally the compressor should be large enough so it does not run continuously (e.g. > 50% of the time), which will cause overheating.
- The extra cost of choosing an oversized system may often be justified. The reduction in duty cycles will lower maintenance costs and extend the life of the system. A suitable compressor coupled to an adequate buffer will ensure a more **constant flow rate** leading to better performance. When spinning, the system uses a constant flow of air, but surges will occur during sample lift. When referring to Compressed Gas Requirements [▶ 57] you should add on 10 l/min. to the average consumption if the system is fitted with anti-vibration devices such as pneumatic dampers or a VIP system.
- Take into account the **pressure loss** along the line between the compressor and the final gate valve. The pressure drop depends on the pipe diameters. An internal diameter of 8 mm has been found to be suitable. The plastic tubing used to carry the supply from the final gate valve to the console has an outside diameter of 8 mm and is supplied by Bruker.
- Some types of **dryers**, e.g., absorption dryers can use up to 25% of the air flow to regenerate the drying material. If this type of dryer is used then the output capacity of the compressor must be sufficient to supply this requirement.
- Many compressors are fitted with dryer and a tray to collect **excess water**. Regular checking of the dryer and emptying of the water collector will ensure trouble free operation. This arrangement is quite satisfactory in environments with normal humidity (< 80%). However in areas of higher humidity (> 80%) a cooling coil with an automatic water drain must be fitted to the compressor outlet. This will ensure that filters do not become overloaded.
- Although not directly concerned with air quality, compressors are a **source of vibrations** which may interfere with NMR performance. You should consider using a compressor fitted with a vibration damping housing if it is to be situated close to the spectrometer. The output noise level should be < 75 dBA.

## 8.3.5.2 Dryers

---

### 8.3.5.2.1 Refrigeration Dryers

---

This type of dryer removes moisture from gas by cooling to within a few degrees of the freezing point of water. The condensed moisture is removed in a separator and drain trap mechanism located immediately downstream of the dryer. This drain should be valve switched automatically.

#### Advantages

- None of the compressed gas is wasted in regeneration which is more suitable if the capacity of the compressor is marginal.
- Maintenance free.
- Not as susceptible to oil mist contamination as adsorption dryers, thus do not have the same need for pre-filters.

#### Disadvantage

- These type of dryers are limited because of their inability to produce very low dew points. The recommended dew point for room temperature work of 4°C is only just achievable. Therefore if low temperature NMR is to be carried out, this type of dryer is unsuitable.

### 8.3.5.2.2 Absorbtion Dryers

---

The air is passed through cartridges of synthetic zeolite known as Molecular Sieves. The sieves are hygroscopic and retain water molecules when air is passed through them. Two sieves are normally used alternatively. A portion of the dry air output of sieve A is fed into sieve B to regenerate it. The amount used in regeneration is typically 15% but up to 25% may be required for very low dewpoints. The process is automatically reversed at regular intervals with the output of sieve B used to regenerate sieve A.

#### Advantages

- Much lower dew points are achievable compared to refrigeration dryers.
- Automatic Regeneration: Normally the sieves will last for many years if they do not become contaminated with oil, e.g. from mist in the air.
- The drying agent may be easily replaced.

#### Disadvantages

- Up to 25% of throughput is used to achieve the automatic regeneration.
- Requires the use of more dust filters.
- Filters at the input (oil < 0.01 mg/m<sup>3</sup>) are required due to the susceptibility to oil contamination from mist in the air.
- The use of absorption dryers may lead to the generation of dust and so the dried air output must be fed through an appropriate filter (1 micron).
- These dryers require more maintenance than refrigeration dryers.
- They can be noisy when switching between the two cartridges.

- Due to the different absorption rates of nitrogen and oxygen the **N<sub>2</sub>/O<sub>2</sub> composition** may change. To prevent this an absorption dryer should be placed between the compressor and buffer tank.

### 8.3.5.3 Filters

---

Micro-filters must be fitted as the last element in the supply line. For specification see the section Compressed Gas Specifications [▶ 57].

Absorption dryers are prone to oil contamination and as such the input must be fitted with a oil filter (oil < 0.01 mg/m<sup>3</sup> 99.9% removal efficiency). To protect the dryers, regardless of type, you are advised to install a water filter and an oil filter between the compressor and the dryer. Adsorption dryers may generate dust and may need extra dust filters at the output.

The output of refrigeration dryers must be fed through a carbon activated filter.

Water filters must be fitted with automatic water drains as opposed to manual drains. The use of valve switched drains is strongly recommended. Floater switched drains have a tendency to become jammed and hence require regular maintenance.

If you are particularly concerned about oil contamination in the air supply then you must consider using a submicron filter followed by an activated charcoal filter as this combination is particularly effective in removing oil.

### 8.3.6 Helium Gas Recovery System

---

Some customers prefer to contract the cryogen maintenance out to local suppliers. Other customers may decide to install a permanent on site supply of cryogens. Helium, in particular, is expensive and recycling of evaporated gas is often economically viable. Financial considerations depend mostly on price and availability of liquid helium, and must be considered in each case individually. In general however, a low loss magnet in an area with regular helium supply will not consume enough helium to pay off the installation costs of a **Helium Gas Recovery System**. For further information regarding such a system contact Bruker.

Storage tanks of course must be situated well away from the magnet room. Where an in-house nitrogen supply is available, the customer must decide whether to pipe the liquid nitrogen directly to the magnet room or to use transport dewars. Experience has shown that the latter option is simpler. Using transport dewars it is easier to keep track of the cryogen evaporation rate when the magnet is filled regularly from a dewar of fixed volume.

## 8.4 Water

---

If the system is equipped with the CryoProbe option and the compressor is water cooled, then cooling water is needed to remove the ca. 7.5 kW of heat output from the water-cooled type He compressor used in conjunction with the CryoProbe. The cooling water requirements for the CryoProbe system are found in the section CryoProbe Utility Requirements [▶ 55].

Microimaging systems may also be water cooled, such as with the Bayvoltex Chiller. Check with the manufacturer of the cooling device or Bruker, for water requirements.

## 8.5 Lighting

---

Operation is most convenient when the computer monitor(s) may be viewed under subdued lighting. However, normal office lighting will be needed in other areas of the NMR room. The most convenient arrangement is to have separately switchable lights using standard light bulbs. Make sure that reflections from strong artificial light do not fall upon the monitor screen. Care should also be taken to minimize reflections from sources such as windows.

- Do not direct spotlights toward the magnet; this could change the surface temperature.
- Consideration should be given to the relative placement of lights to the air conditioning inputs, which mostly contain the temperature sensors for the air conditioners. Otherwise the switching of lights might result in a system over-reaction and a considerable temperature change.
- Lights are generally not recommended within a radius of 3m (~10') from the magnet.

## 8.6 HVAC (Heating Ventilation Air Conditioning)

---

Constant air pressure, temperature and humidity is crucial for high performance operation. Ideally, an absolute room temperature of between 17-25°C should be kept.

**Room should not fluctuate** more than +/- 1°C for 300-500 MHz systems, and +/- 0.5°C for 600 MHz and above, per hour, near the magnet or cabinets. Even with small changes within this narrow range, it is essential that these are random and there is **no periodicity of temperature changes**. Air drafts, particularly those created from air conditioning or heating systems, can have negative effects on the magnet., thus the location and orientation of air-diffusers must prevent the air from blowing towards the magnet and spectrometer cabinet. If possible, it is recommended to have the exhaust (air-return) closer to the NMR spectrometer equipment (AVANCE console, UPS, BMPC II, CryoCooling unit, BCU-I) that releases most of the heat output into the space. This would help with removing the heat closer to its sources and ultimately help with the overall temperature stability in the room.

Humidity should be kept between **30% and 80%**. Conditions other than these may warrant the installation of an air conditioner with appropriate humidity controls.

The heat output of the standard AVANCE system for high resolution work is about 4.6 kW (18,000 BTU/hr.). This includes the main AVANCE cabinet, the BMPC (high frequency systems only), the BCU-I, and the workstation.

The heat output of the AVANCE system equipped with High Power amplifiers for solids NMR is between 6 kW (25,000 BTU/hr.) to 10 kW (40,000 BTU/hr.) depending on the high power configuration.

### See also

- 📖 Emergency Ventilation During Installation and Quenches [▶63]

### 8.6.1 Avance System Stability

---

The following table lists the heat generated by various systems. The heat output is constant and it is essential to minimize or avoid short term oscillations of the HVAC system, and provide a continuous slow flow of air that in turn reduces the speed of any temperature changes. In other words, it is recommended to have a continuous and slow exchange of air in the NMR room, hence minimizing fluctuations. Most of the heat is generated in the AVANCE cabinet, the magnet pump assembly and the BCU-I. The magnet itself does not dissipate any heat.

System	Heat Generated
AVANCE TwoBay (with 3 channels & BCU-I)	3.00 kW peak*
AVANCE OneBay	2.50 kW peak
AVANCE MicroBay (3 channels)	2.00 kW peak
AVANCE NanoBay	Not available
Imaging Cabinet	1.0 kW average
BMPC II (high frequency systems only)	0.7 kW average, 1.25 kW peak
BCU-I, BCU-II	BCU-I: 0.5 kW average BCU-II: 1.5 kW average, 2.4 kW peak
Gilson	Approx. 0.5 kW average
CryoCooling Unit	0.5 kW average, 0.8 kW peak
He Compressor (note: heat from the outdoor He compressor is not dissipated inside the room)	7.5 kW average 8.5 kW peak
* A TwoBay configured for solids can generate a peak of 5.0 kW.	

Table 8.4: Heat Generated by Typical AVANCE Systems

The temperature of any air or nitrogen flow attached to the probe must be stable. This is particularly relevant if the compressed gas flow is piped into the magnet room from outside the building.

## 8.6.2 Atmospheric Pressure Changes

Rapid changes in the temperature may result in atmospheric pressure changes. High atmospheric pressure could reduce the helium boil off if the magnet cryostat is not equipped with an electronic atmospheric pressure device. The boil-off rate could be even lower than the minimum value which could be measured by the flow meter. Electronic **atmospheric pressure devices**, which, for example, holds the pressure at 1030 hPa, stabilize field drift and helium boil-off when changes in atmospheric pressure occur. The atmospheric pressure device is available as an option for many Bruker magnets, contact Bruker for details.

## 8.7 Emergency Ventilation During Installation and Quenches

Due to the large amount of liquid helium contained in the magnet, an emergency exhaust system may be required to prevent O<sub>2</sub> depletion during a magnet quench.

Likewise, during the installation, refilling and cooling of superconducting magnets, large volumes of nitrogen or helium gases may be generated under certain conditions. Although these gases are inert, if generated in large enough quantities, they can displace the oxygen in the room causing potential danger of suffocation.

The following table lists the maximum helium capacity and the typical gas flow rates for helium gas during a quench for current magnet systems. Generally, the gas flow rate is equal to half the volume in one minute.

## Utility Requirements

Magnet Type	Minimum Helium Capacity (m <sup>3</sup> )	Gas Flow Rate (m <sup>3</sup> )
200 MHz/154 mm US PLUS LH	40.4	20.2
300 MHz/54 mm US LH	39.2	19.6
300 MHz/54 mm Fourier US LH	39.2	19.6
300 MHz/54 mm Ascend ULH	83.6	41.8
300 MHz/89 mm Ascend	99.9	50.0
300 MHz/154 mm US PLUS LH	74.8	37.4
400 MHz/54 mm Ascend	75.5	37.8
400 MHz/54 mm Ascend ULH	101.4	50.7
400 MHz/54 mm Ascend RS	106.6	53.3
400 MHz/89 mm Ascend	75.5	37.8
400 MHz/89 mm Ascend DNP	75.5	37.8
400 MHz/154 mm US PLUS LH	150.3	75.2
500 MHz/54 mm Ascend	62.9	31.5
500 MHz/54 mm Ascend ULH	162.8	81.4
500 MHz/54 mm Ascend RS	180.6	90.3
500 MHz/89 mm Ascend	75.5	37.8
500 MHz/154 mm US PLUS LH	150.3	75.2
600 MHz/54 mm Ascend	65.2	32.6
600 MHz/54 mm Ascend ULH	261.3	130.6
600 MHz/89 mm Ascend	96.2	48.1
600 MHz/89 mm Ascend DNP	96.2	48.1
700 MHz/54 mm Ascend	97.7	48.9
750 MHz/54 mm Ascend	244.2	122.1
750 MHz/89 mm Ascend	350.1	175.1
LH = Long Hold, ULH = Ultra Long Hold		

Table 8.5: Maximum Helium Capacity and Gas Flow Rate

Regarding the emergency gas exhaust, important considerations include, but are not limited to, the following:

- Amount of liquid helium:** Taking the 750 WB US<sup>2</sup> magnet as an example, the total amount of liquid helium is 473 liters. In case of a quench, the liquid transforms into gas and expands by a factor of 740. Therefore, the total amount of helium evaporated gas in case of a quench will be ca. 350 m<sup>3</sup> (12,360 ft<sup>3</sup>).
- Maximum helium gas flow:** The maximum flow of helium gas is calculated on the assumption that half of the volume of liquid evaporates in 1 minute, thus the maximum flow would be 175 m<sup>3</sup> (6,180 ft<sup>3</sup>) for the 750 WB US<sup>2</sup> magnet. The gas should be removed from the room immediately through an emergency exhaust system.
- O<sub>2</sub> level sensors:** Oxygen level sensors are required to detect low O<sub>2</sub> levels within the NMR room for each system. One sensor is needed above the magnet for detecting low O<sub>2</sub> levels due to He gas exhaust in case of a quench or during He fills. An additional sensor is needed

close to the floor for detecting low O<sub>2</sub> levels due to N<sub>2</sub> gas exhaust during magnet cooling or regular N<sub>2</sub> fills. In case of placing the magnet inside a pit, a third sensor is needed inside a pit to detect low O<sub>2</sub> levels from N<sub>2</sub> gas.

- **Emergency exhaust solutions:** Refer to the section Emergency Exhaust Solutions [▶65].



### **Pits:**

When a magnet is installed in a pit, it is important to ensure there is continuous air-flow (exhaust) within the pit. This is done to prevent any buildup of nitrogen gas in the confines of the pit.

## 8.7.1 Emergency Exhaust Solutions

In many cases doors and windows will provide sufficient ventilation in larger rooms. It is important to compare the volume of helium gas that would be released after a quench and the space volume of the NMR magnet room, in order to determine the optimum and practical solution for emergency ventilation. Generically it is recommended that an emergency exhaust system be installed in smaller rooms, or rooms not connected to the outside. The following exhaust solutions are recommended:

### **Passive Exhaust**

This system is based on louvers in the ceiling, or upper parts of outside walls, that open up due to the pressure of helium gas.

### **Active Exhaust**

In addition, an active system based on a purge fan and exhaust duct close to the ceiling is recommended. This way, adequate exhaust of cryogenic gases will be provided not only during a quench, but also during the initial cooling of the magnet and regular cryogen refills.

Normally it is sufficient to operate this fan manually, as the probability of an unattended quench after the installation is rather low.

If desired, this fan can be operated with an automatic switch:

- it should be installed in addition to a manual switch.
- measures should be taken to prevent it from being turned on during a fire.

### **Quench Pipes**

This solution may be required when the NMR room is small and any of the other options are not sufficient to ensure safety after a magnet quench.

This solution is based on a pipe connected directly to the magnet, which is then routed to the outside of the building. It is important to note the following:

- The helium exhaust from the magnet should be vented directly to the outside of the building.
- The ducts should have sufficient diameter to avoid excessive pressure build-up due to the flow impedance of the duct.
- The location of the exit end of the duct must not be accessible to anyone other than service personnel. In addition the exit opening should be protected from the ingress of rain, snow, animals, etc.

- It is also essential that any gas which vents from the exhaust duct cannot be drawn into the air conditioning or ventilation system intakes. The location of the duct's output should be carefully sited to prevent this from happening during any adverse atmospheric conditions and winds.
- Insulation of exhaust piping should also be provided to prevent cold burns and O<sub>2</sub> condensation during a quench.

### Pits

---

#### Pits:



As discussed in HVAC (Heating Ventilation Air Conditioning) [▶ 62], continuous air flow (exhaust) is required within the confines of a magnet pit. A low exhaust down in the pit is recommended. Additional emergency ventilation may also be necessary, particularly if the pit is >1.09m (3.5') deep (average mouth-height of a person). Since nitrogen gas cannot be detected by the human senses, an oxygen sensor mounted in the pit will trigger an increased rate of exhaust.

---



Figure 8.2: Emergency Quench Pipes

#### Exhaust for Ceiling Soffits

The opposite of a pit, a soffit is a hole that has been cut in the ceiling to facilitate cryogen fills and/or the magnet installation. Though it is not required to install ventilation in a soffit, it is important to understand that the soffit will be the first area to fill up with helium gas during a quench or during a helium fill. It is important to elicit extra caution in this case.

A passive louver or an exhaust duct with fan are practical solutions when soffits are used.

## Air Conditioning as an Exhaust

It is recommended that the air conditioning system be adequate to dissipate the sudden gas buildup during a quench. In addition the air conditioning must have a safety feature which **draws all the air out** of the room and **brings fresh air** in during a quench, rather than just recirculating the old air through the system. The air conditioning system could, for example, be connected to an oxygen level sensor.

Please contact Bruker for further information on exhaust solutions.

## 8.8 Fire Detection System and Fire Extinguishers

---

Rooms containing NMR magnets should be equipped with **temperature sensors** for fire detection. These must respond *only* to a sudden rise of temperature, and not be triggered by a quench (sudden drop of temperature).

Optical sensors cannot discriminate between smoke from a fire and fog caused by a quench so these may not be used.

**Fire extinguishers** in the vicinity of the magnet room must be **non-magnetic** (stainless steel or aluminum). It is the obligation of the customer to inform the local fire department about the dangers of magnetic fields. These magnets stay at field for a long time even in a most blazing fire!

Ceiling sprinkler heads should be made of metal instead of glass. A quench could falsely trigger the alcohol-filled glass vials, which can shatter in the presence of cold helium gas. Sprinklers should not be located directly over the magnet.

Any sprinkler lines or other metal pipes located above the magnet should be thermally-insulated to prevent O<sub>2</sub> condensation or water freezing in the line from the large amount of cold He gas following a magnet quench.



# 9 Floor Plan

## 9.1 Size and Mass of Equipment

The floor of the NMR room must be sufficiently strong to support the console, magnet, and ancillary equipment. The following tables provide the dimensions and weights of NMR equipment, and the footprint and weight of magnets (filled with cryogens and including stand). The floor should also be as rigid as possible to reduce the effect of vibrations.

Component	Width (m)	Depth (m)	Height (m)	Weight (kg)
AVANCE Cabinet	1.31	0.83	1.55	454
Table / Workstation	1.20	1.00	0.75	68
Microlmaging Cabinet	0.69	0.83	1.55	205 / 150
B-CU-I	0.50	0.55	0.48	46
BCU-II	0.55	0.59	0.74	74
BMPC II (for high frequency systems)	0.85	0.70	1.70	254
UPS - Main Unit (for high frequency systems)	0.3	0.6	0.7	165
- Battery Pack	20.34	90.62	20.79	216
For the CryoProbe option refer to The CryoProbe System [▶79].				

Table 9.1: Dimensions and Weights of NMR Equipment

## 9.1.1 Magnet Dimensions

The values in the following table correspond to the following figure:

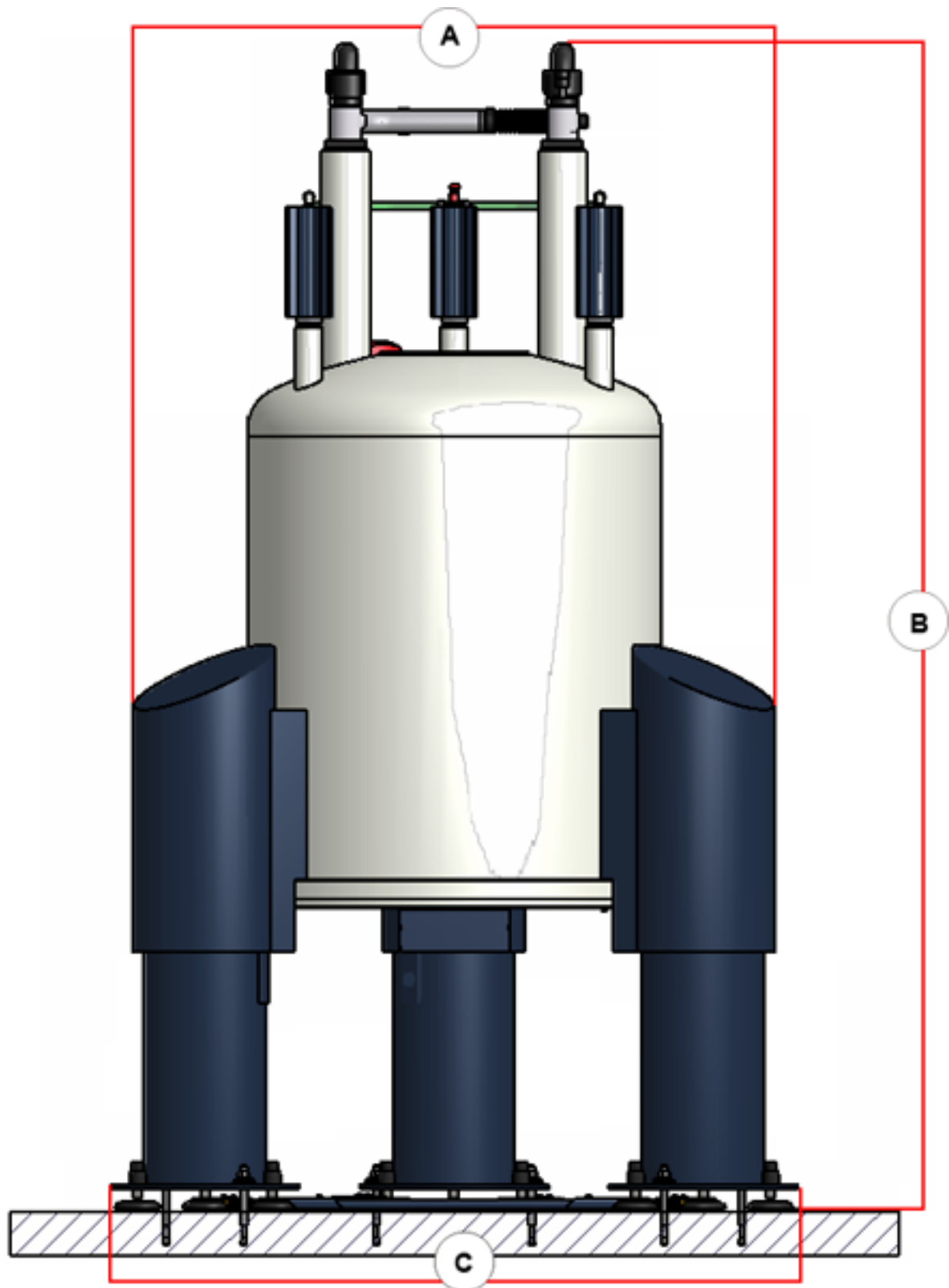

Figure 9.1: Magnet Dimensions

A.	Maximum magnet diameter
B.	Magnet height from the floor, including stand.
C.	Overall footprint diameter
<i>Refer to the Magnet Dimensions and Total Weights table for the values of A, B, and C.</i>	

## 9.1.2 Magnet Dimensions and Total Weight

Magnet	A Maximum Magnet Diame- ter (m)	B Magnet Height from the Floor Including Stand (m)	C Overall Foot- print Diameter (m)	Total Magnet Weight incl. Stand & Cryo- gens (kg)*
200 MHz/154 mm US PLUS LH	0.85	2.75	1.43	780
300 MHz/54 mm US LH	0.72	1.93	0.89	292
300 MHz/54 mm Fourier US LH	0.72	1.93	0.89	292
300 MHz/54 mm Ascend ULH	1.30	2.14	1.38	411
300 MHz/89 mm Ascend	1.30	2.49	1.38	540
300 MHz/154 mm US PLUS LH	0.85	2.75	1.43	780
400 MHz/54 mm Ascend	1.30	2.14	1.38	484
400 MHz/54 mm Ascend ULH	1.30	2.14	1.38	532
400 MHz/54 mm Ascend RS	0.85	2.27	1.46	548
400 MHz/89 mm Ascend	1.30	2.49	1.38	682
400 MHz/89 mm Ascend DNP	1.30	2.72	1.38	850
400 MHz/154 mm US PLUS LH	1.10	3.09	1.79	2000
500 MHz/54 mm Ascend	1.30	2.14	1.38	650
500 MHz/54 mm Ascend ULH	0.95	2.61	1.67	1050
500 MHz/54 mm Ascend RS	0.85	2.27	1.46	675
500 MHz/89 mm Ascend	0.80	2.72	1.38	770
500 MHz/154 mm US PLUS LH	1.10	3.09	1.79	2000
600 MHz/54 mm Ascend	0.80	2.47	1.38	850
600 MHz/54 mm Ascend ULH	1.10	2.84	1.79	1435
600 MHz/89 mm Ascend	0.95	2.86	1.67	1446
600 MHz/89 mm Ascend DNP	0.95	2.86	1.67	1446
700 MHz/54 mm Ascend	0.95	2.61	1.67	1446
750 MHz/54 mm Ascend	1.10	2.84	1.79	~1874
750 MHz/89 mm Ascend	1.37	3.04	2.18	~2908
LH = Long Hold, ULH = Ultra Long Hold				
* With standard magnet stand, the weight with optional stands will vary.				

Table 9.2: Magnet Dimensions and Total Weights

## 9.2 Magnet Location

---

When locating the magnet, certain considerations must be made with regards to the laboratory environment:

- To increase magnet homogeneity, the magnet should be located away from permanent iron structures such as support beams in walls and floors. Reference: Electromagnetic Interference [▶ 48].
- To increase temperature stability, the magnet should not be placed in direct sunlight or near any artificial heat source. The magnet should also not be placed under or in close proximity to air-vents or in an area that experiences air drafts. Air should not be blown directly down or towards the NMR magnet.
- When possible, avoid a situation where a significant stray field ( $>5\text{ G} / 0.5\text{ mT}$ ) extends into adjacent rooms.
- There should be free access to the magnet from all sides.

It is important to determine the optimal position in the NMR room, based on the following orientation elements:

- **The front of the manifold:** The front of the helium manifold is defined by a U-shaped opening. The manifold connects the two (or three) helium turrets at the top of the magnet.
- **The He fill port:** The right turret (when looking at the front of the magnet) is the helium fill port. It is necessary to provide a path to either the right side or the front of the magnet so liquid helium transport dewars can be rolled in place.

## 9.3 Minimum Floor Capacity

---

The floor must be sufficiently strong to support the mass of the equipment, plus the weight of any installation devices, e.g. forklifts, hoists etc. The floor must also be as rigid as possible to reduce the effects of vibration. Wooden floors tend to have resonance frequencies of 10-15 Hz, whereas concrete floors display a resonance frequency in the 30-50 Hz range. Since higher frequencies are much more easily dampened by various devices, concrete floors will lead to less vibration problem than wooden floors.

## 9.4 Floor Types

---

Generally a **liquid nitrogen resistant floor material** must be used, such as PVC or wood that has been painted or varnished. Unfinished wood must not be used as this will absorb liquid nitrogen. This also implies that wood floors must be regularly maintained to help prevent absorption.

Many of the system components contain highly sensitive electronic devices that must be protected from **Electrostatic Discharge** (ESD) by proper floor covering and grounding practices.

To prevent ESD damage in the magnet room, the system must be installed on an ESD resistant flooring such as vinyl, and properly grounded. One of the most important characteristics of an **ESD resistant floor** is its ability to conduct charges to ground. The second most important aspect is its **anti-static property**.

## 9.5 Magnet Platform

For smaller magnet systems, ladders and small platforms are most commonly used to facilitate sample insertion, cryogen fills, etc.

Ladders for platforms must be constructed of wood or aluminum to keep magnetic interference down to a minimum.

If climbing a ladder is not a feasible option, a magnet platform may be required. These are typically built to facilitate sample insertion on the larger systems (600 MHz and up), however smaller platforms can be used on smaller systems.

The platform must be constructed of wood or other non-magnetic material. It must accommodate the magnet and provide safe access for sample insertion and cryogen fills. Consult your Bruker office for further guidelines when using a magnet platform.



Figure 9.2: Example of a Simple Magnet Platform

## 9.6 Magnet Pits

If the ceiling height is not sufficient, then a magnet pit may be an option. Important issues that need attention include but are not limited to the following:

- Special rigging equipment and a temporary platform to support and lower magnet inside the pit.
- Continuous ventilation and emergency exhaust inside the pit (please refer to special notes related to pits in sections HVAC (Heating Ventilation Air Conditioning) [▶ 62] and Emergency Ventilation During Installation and Quenches [▶ 63]).
- Magnet refills and access for transport dewars.
- Cable lengths.
- Tuning and matching the probe.
- Siting the BCU-I or BCU-II cooling unit.
- Siting the CryoPlatform™.

Consult your local Bruker Installation Engineer for pit design and construction details.



*Figure 9.3: Example of a Magnet Pit*

### **9.7 Maximum Field Strengths for NMR Equipment**

---

Once the location of the magnet has been decided, it is time to determine where the remainder of the equipment will be placed. Protection of motors and electronics from magnetic stray fields is crucial.

Unit	Maximum Field Strength
AVANCE cabinet	1.0 mT (10 G) line
TFT computer monitor	1.0 mT (10 G)*
Computers e.g. NMR workstation, PC	0.5 mT (5 G)
CPMAS, Micro-imaging, high power units	1.0 mT (10 G)
Printer Plotter	0.5 mT (5 G)
Gas cylinders	0.5 mT (5 G)
Heavy metal office furniture e.g. filing cabinet**	0.5 mT (5 G) - not recommended in magnet room
Movable metal chair	Not recommended in magnet room
BCU-I, BCU-II	5.0 mT (50G) - max. 2.7m from magnet center
LC-NMR system & accessories	0.5 mT (5 G)
He compressor (CryoCooling)	0.5 mT (5 G)
Gilson	0.5 mT (5 G)
BMPC II (high frequency systems only)	1.0 mT (10 G)
CryoProbe system components (e.g. He steel cylinder and its transport path)	0.5 mT (5 G)
CryoCooling unit	5.0 mT (50 G)
* The working place for personnel should be outside the 0.5 mT (5 G) line. An additional TFT monitor and keyboard can be located at the 1.0 mT (10 G) line for probe adjustments etc.	
** Use wooden furniture if access during critical measurements is required.	

Table 9.3: Maximum Field Strength for NMR Equipment

## 9.8 Automation Considerations

Bruker **sample changers** have been developed for most magnet systems. These sample changer's multiple NMR sample tubes and can be used in conjunction with any of the low or high field magnets. The sample changers utilize mechanical mounting equipment to attach the sample changer to the magnet. This allows for easy sample changer adjustment in X, Y, and Z directions.

**Micro-imaging and high power cabinets** are not as sensitive to the magnet stray field as units contained in the main AVANCE cabinets. In terms of performance they will operate satisfactorily at fields of up to 2 mT. However at this distance they may interfere with the magnet homogeneity and so it is recommended that they be kept beyond the 1 mT line.

Contact Bruker for site considerations if planning on any other automation options.

## 9.9 Cabinet Position

The various units within the AVANCE™ cabinet, especially the acquisition computer, must be kept at a minimum distance from the magnet. Protection of the acquisition computer and digital electronics from the magnet's stray field is best achieved by positioning the cabinet so that the acquisition computer is no closer than the 1.0 mT (10 G) line. Any ancillary cabinets such as microimaging or high power must also be placed outside the 1.0 mT (10 G) line (see Maximum Field Strengths for NMR Equipment [▶74]). To allow adequate ventilation for the cabinet, it must

be positioned no closer than 30 cm from the back of the cabinet to any walls. For service access to the rear, there must be sufficient space for the cabinet to be pulled out from the wall. For ease of cabling, locate electrical outlets and compressed air supply close to the rear of the cabinet.

## 9.10 Worktable Position

---

Magnetic storage devices are sensitive to the stray field and attention must be given to their position relative to the magnet.

- The flat LCD panel should be turned (or able to be turned) towards the magnet to facilitate tuning and matching.
- The workstation and additional disks, CD-ROM drives, etc., which are normally placed on the worktable, should not be exposed to fields greater than 1.0 mT (10 G).
- For convenience of operation, no direct light should fall on the LCD panel, nor should there be a strong light source at the back of the panel. A separate dimmer or at least partial switching is recommended for the lights in the worktable area.

## 9.11 Service Access Requirements

---

The following recommendations will ensure that there is sufficient space for accessing the system, as well as providing adequate ventilation:

- Ventilation: A minimum of 30 cm must be left between the back of the cabinet and any wall to ensure proper ventilation.
- Service access - AVANCE: Sufficient space (~ 60 cm) must be left in front of the AVANCE so the cabinet may be pulled away from the wall for service. Service access to the sides is not required.
- Service access - Magnet: There must be enough space between the magnet legs and the wall such that a service person can walk all the way around the magnet. Also, when refilling the cryogen levels, large dewars must be brought close to the magnet. Ensure that the magnet room is suitably spacious to allow easy access for the dewars. If a platform is not used then there must also be enough room for a ladder. As a rule of thumb the magnet must be accessible to a distance of 2 m over at least half of its circumference and be no closer than 0.77 m to the nearest wall.

The following are miscellaneous, but important things to think about when creating a workable floor plan:

- For ease of cabling, locate electrical outlets and compressed air supply close to the rear of the cabinet and by the magnet.
- The door to the magnet room must be easily accessible from all parts of the room. It is advantageous to have the doors located so that traffic through the room does not approach the magnet.
- As a rule gas cylinders must be stored outside the room. If for any reason they must be placed in the magnet room located as far away from the magnet as possible and secured properly to a wall well outside the 5 Gauss.
- Ensure that convenient and safe pathways are available so that cryogen transport dewars can easily be moved into and out of the magnet room. This includes making sure that the cryogen dewars do not run over cabling, and that the equipment/furniture is located to allow for access.
- Make provision for sample/solvent preparation and storage space, documentation storage space, personal computers, printer/plotter tables, workstations etc.

- Under no circumstances should movable office chairs made of magnetic material be used in the NMR room.
- Make provision for installing a telephone and lines for, e.g. Internet access. It is most convenient if the operator can use the phone while sitting at the spectrometer worktable.

Finally, before a final layout is decided, consider future equipment that may need to be installed. Remember that once installed, the magnet must not be moved.

### Layout Examples

The following layout examples of some NMR systems include the equipment and utilities. A description of each of the NMR system components is presented in the chapter Equipment [ 17], while the details regarding the utility requirements are presented in the chapter Utility Requirements [ 53].

If a CryoProbe System is planned, be sure to refer to The CryoProbe System [ 79] for specific information on CryoProbe site requirements.

## Avance 400MHz/54mm US Layout

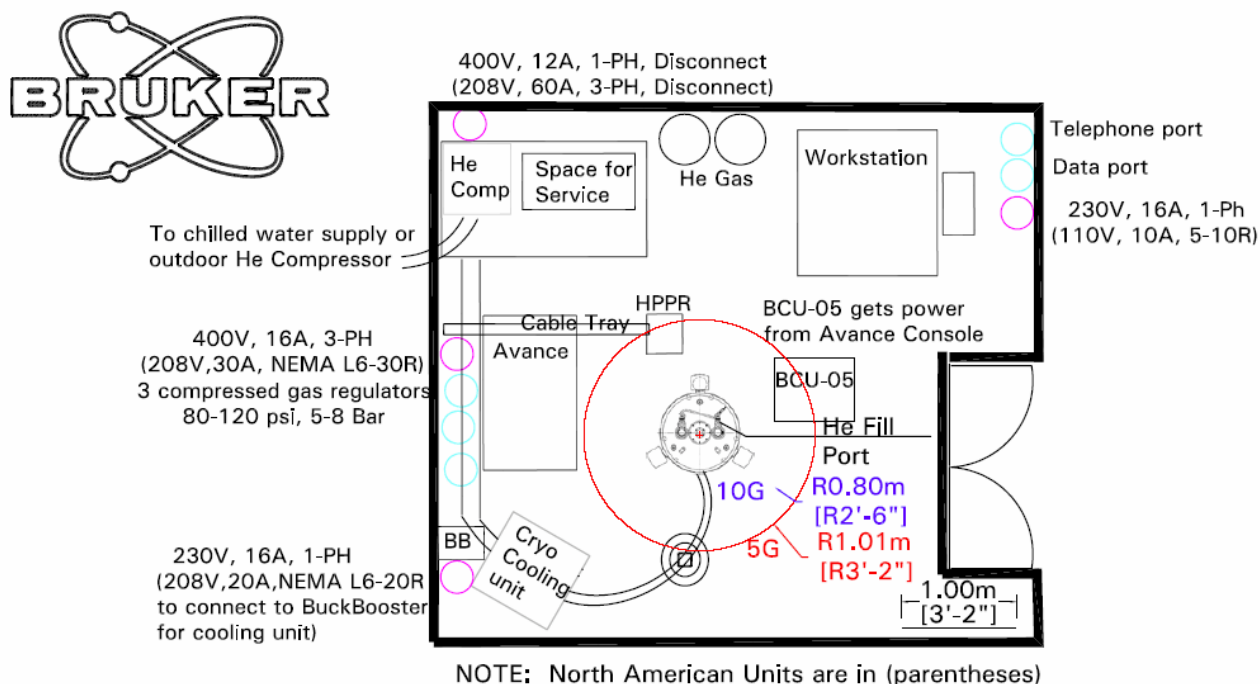

Figure 9.4: AVANCE 400 MHz Example Layout

# Avance 600MHz/54mm US Layout

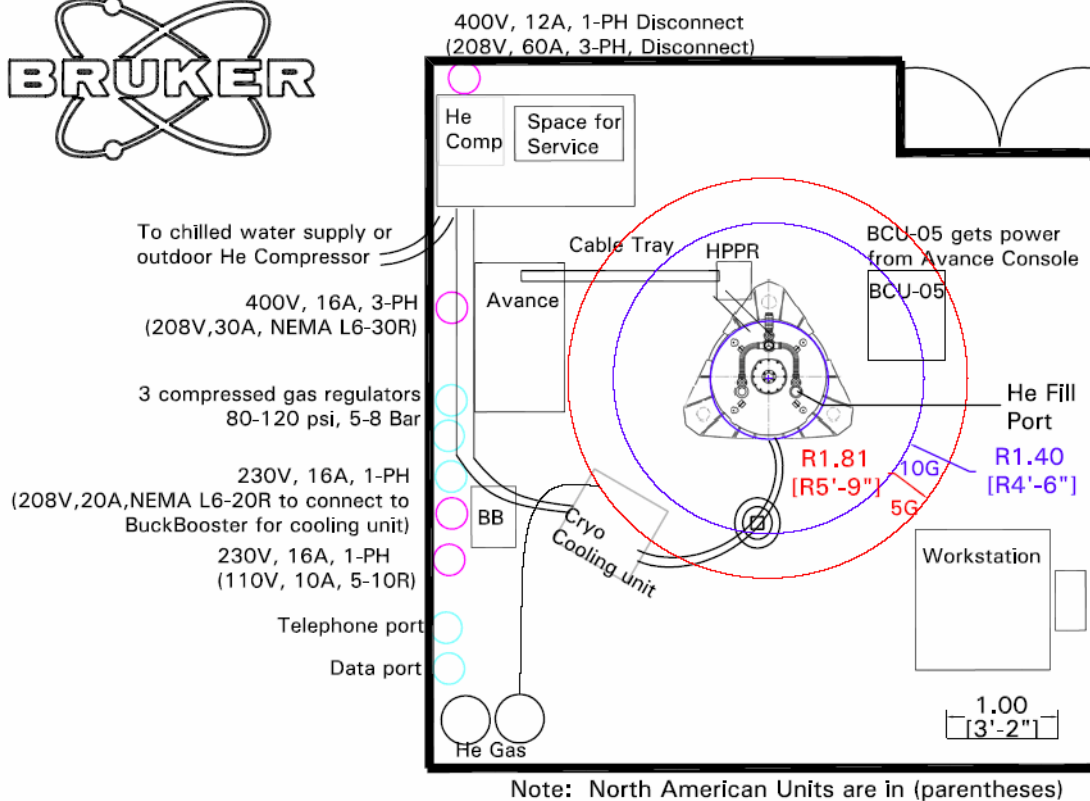

Figure 9.5: AVANCE 600 MHz Example Layout

# 10 The CryoProbe System

The CryoProbe accessory for the AVANCE™ Series NMR Spectrometers offers dramatic increases in signal to noise ratio (S/N) by reducing the operating temperature of the NMR coil assembly and the preamplifier.

The CryoProbe accessory consists of two major components: the CryoProbe and the CryoPlatform. The CryoProbe is similar to a standard probe, however contains cryogenically cooled RF coil and electronics. The CryoPlatform, which provides cryogenic cooling for the CryoProbe, is made up of:

- CryoCooling Unit with control electronics.
- Helium Compressor (along with any associated cooling equipment).
- Helium Gas Cylinder (for purging of the CryoProbe).
- Helium transfer lines and transfer line support.

The CryoCooling Unit must be sited adjacent to the magnet, whereas the Helium Compressor and Helium Gas Cylinder may be sited remotely. The first step in the site planning involves review of the magnet area to determine if floor space is available to accommodate the CryoCooling Unit. The CryoCooling Unit is optimally located level with the magnet. Other configurations, such as magnet pits that can not accommodate the CryoCooling Unit, require special consideration.

# The CryoProbe System

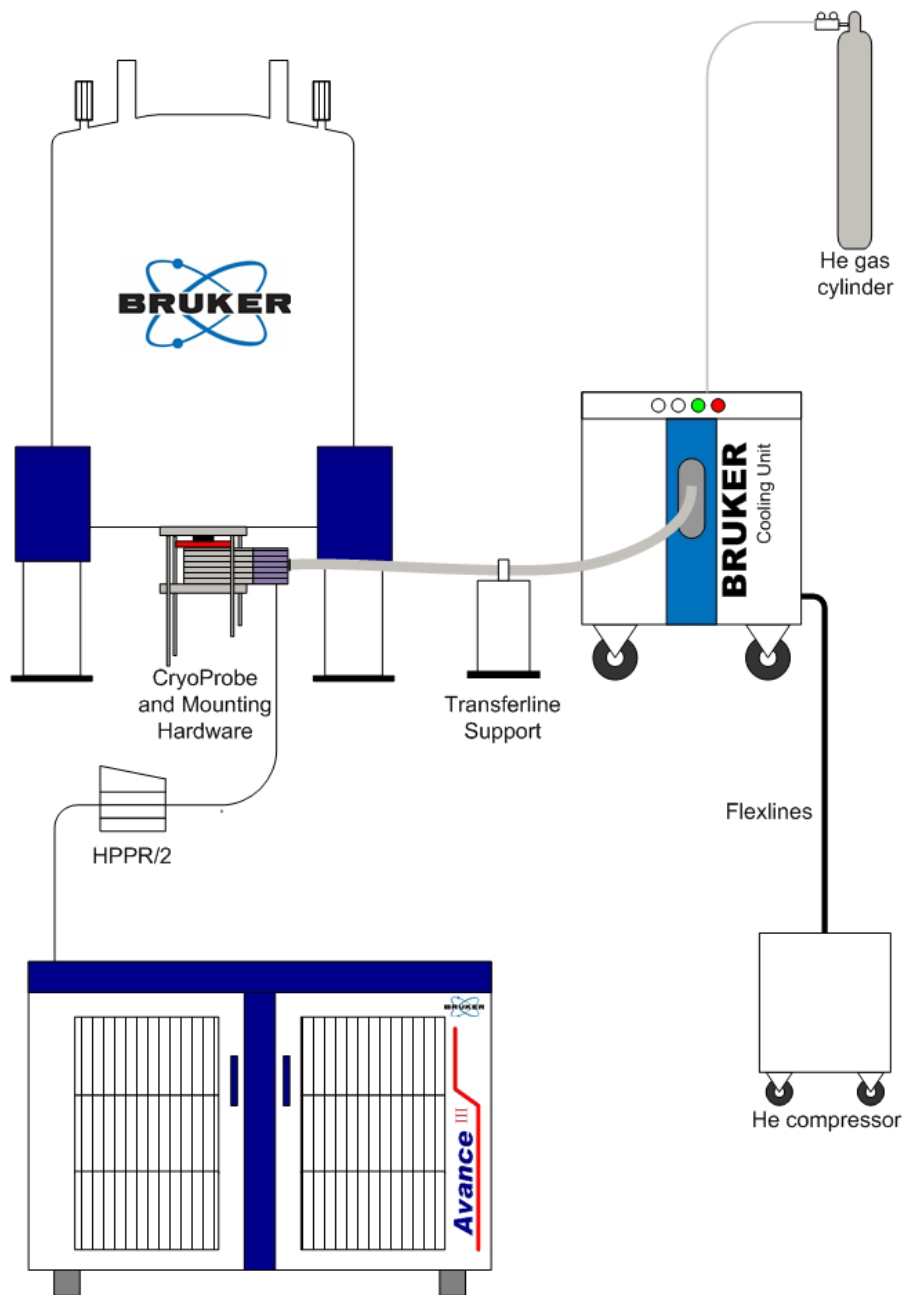

Figure 10.1: CryoProbe System Overview

Refer to the layout examples for more information.

## 10.1 CryoCooling Unit

The CryoCooling Unit is installed adjacent to the magnet outside the 50 Gauss (5 mT) line. The shim cable must be 180° from the CryoProbe front plate. The shim stack may be rotated if necessary.

Dimensions:	Width: 68 cm Depth: 89 cm Height: 96 cm
Weight:	400 kg
Voltage:	230 V AC +/- 10%, 1 phase, 50-60 Hz.
Required external fuse upstream:	T 10 A (T = time-lag fuse)
Power consumption:	Peak 0.8 kW Average 0.5 kW (systems produced before June 2005: peak power of 1.5 kW)
Acoustic noise:	Maximum 61 dB(A) 2 meters distant
Maximum room ambient temperature:	30°C. No operation above this temperature is approved.
Helium gas supply:	A high purity helium (He) gas cylinder (6 N = 99.9999% or better, maximum impurity concentration 1 ppm).
Compressed air or nitrogen supply:	With a pressure of > or = to 4.5 bar.
Position:	Outside 50 Gauss (5 mT) stray field.

Table 10.1: CryoCooling Unit Specifications

## 10.2 Helium Compressors

The next step in the site planning for a CryoProbe accessory involves determining the type and location of the helium compressor. Since the helium compressor generates a considerable amount of heat (7.5 kW average, 8.5 kW peak), it must be cooled to prevent overheating. Bruker offers both water cooled and air cooled helium compressors. In either case, placing the compressor in a remote room (up to 20 meters away) or an enclosure will keep the noise of the unit out of your laboratory. Outdoor helium compressors may be sited up to 40 meters from the CryoCooling Unit.

### 10.2.1 Available Models

Three models of helium compressors are currently available. All the compressors must be sited outside the 5 Gauss (0.5 mT) line, generate the same amount of heat (7.5 kW average) and have the same power requirements (3 Phase, 208 V). The correct helium compressor for your laboratory may be determined based on the desired location for the unit (indoor, outdoor, and distance from the CryoCooling Unit) and the availability of a chilled water supply. Helium transfer lines connect the helium compressor to the CryoCooling unit and are available in several different lengths as shown below.

# The CryoProbe System

## 10.2.1.1 Helium Compressor - Indoor Water Cooled

- Requires chilled water source (supplied by customer) with a flow of  $\geq 420$  L/Hr, incoming temperature  $\leq 25^\circ\text{C}$ . Caution: Do not use demineralized or deionized water.
- Ambient operating temperature  $5\text{--}28^\circ\text{C}$ .

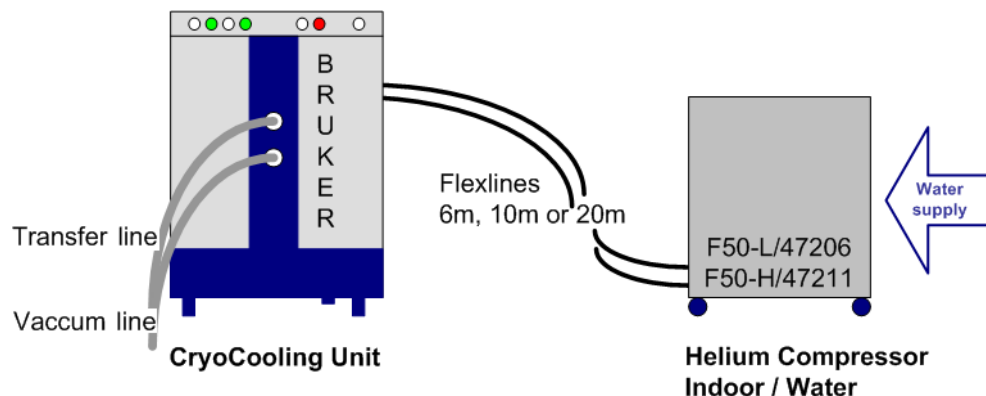

Figure 10.2: Helium Compressor - Indoor Water Cooled

## 10.2.1.2 Helium Compressor - Indoor Air Cooled

- The room air handling system must be able to dissipate 7.5 kW of heat. The low power version (400 MHz systems only) requires dissipation of 4.8 kW.
- Siting this helium compressor in the same room as the NMR is not recommended.
- Ambient operating temperature  $5\text{--}28^\circ\text{C}$ .

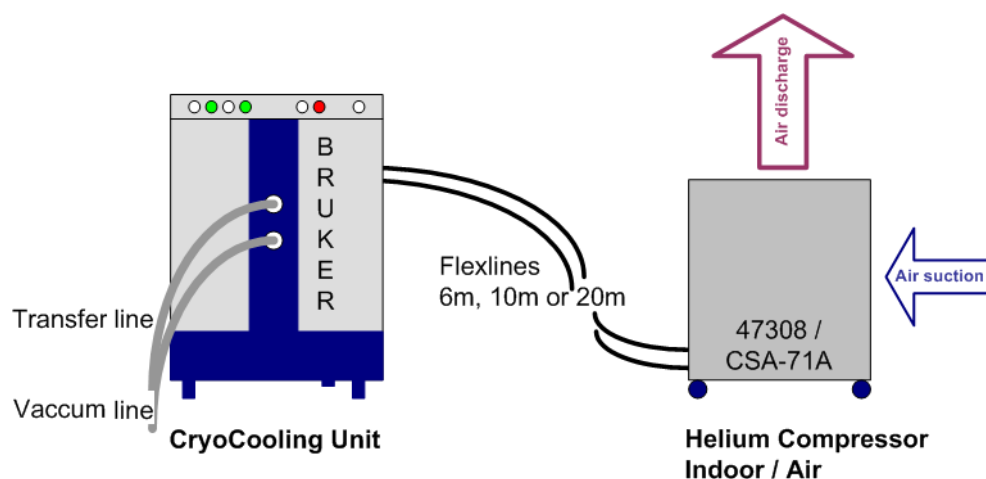

Figure 10.3: Helium Compressor - Indoor Air Cooled

## 10.2.1.3 Helium Compressor - Outdoor Air Cooled

- The Outdoor Air Cooled helium compressor consists of an Outdoor Unit and an Indoor Unit.
- The outdoor unit is specified to operate between the temperatures of  $-30^{\circ}\text{C}$  to  $45^{\circ}\text{C}$ .

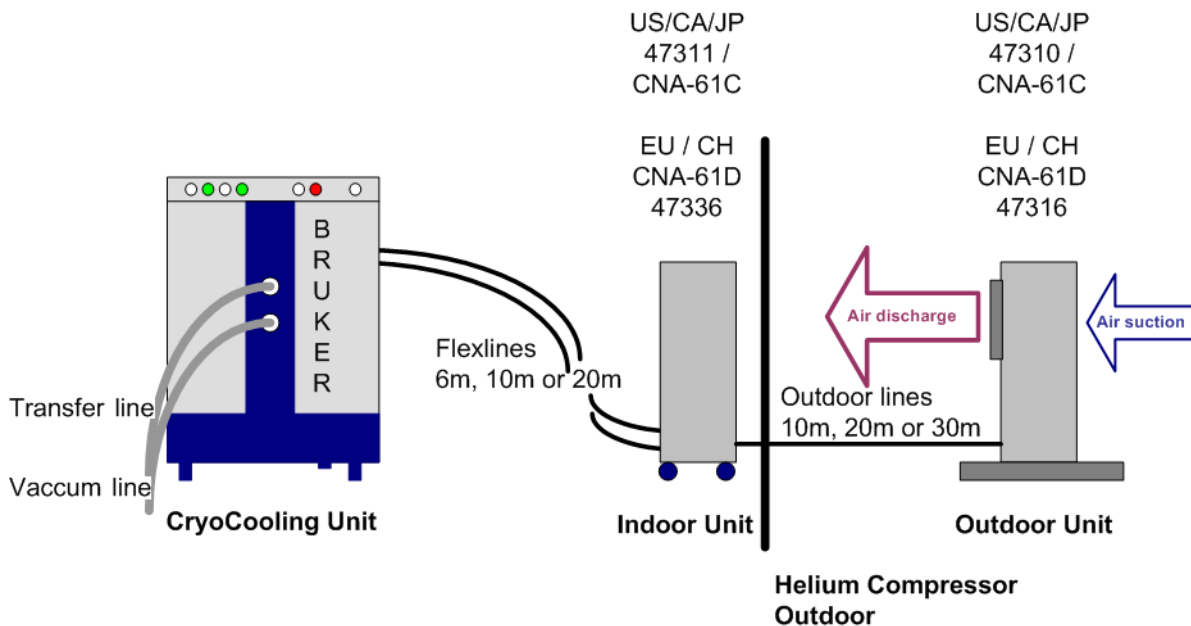

Figure 10.4: Helium Compressor - Outdoor Air Cooled

## 10.2.2 Space Requirements and Specifications

### 10.2.2.1 Indoor Helium Compressors

The indoor helium compressors (air or water cooled) have space requirements to allow for air-flow and servicing the unit. The minimum room space needed is 1.25 m (width) x 0.8 m (depth) x 0.7 m (height).

Sumitomo Type:	F-50L	F-50H	CSA-71A
Type of Compressor:	Water-cooled	Water-cooled	Air-cooled
Dimension:	Width: 45 cm Depth: 48.5 cm Height: 59.1 cm	Width: 45 cm Depth: 48.5 cm Height: 59.1 cm	Width: 55 cm Depth: 55 cm Height: 88.5 cm
Weight:	120 kg	120 kg	140 kg
Voltage:	3 x 200 V	3 x 400 V (380, 400, 415 @ 50 Hz, or 460, 480 @ 60 Hz	3 x 200 V @ 50/60 Hz US no plug supplied
Mainly delivered to:	USA/CA/JP	EU/CH	USA/CA/JP
Operating Current:	26 A	13 A	25 A
Minimum Circuit Am- pacity:	35 A	17 A	35 A

Sumitomo Type:	F-50L	F-50H	CSA-71A
Maximum Fuse Size:	60 A	30 A	60 A
Compressor LRA:	160 A	75 A	100 A
Power Requirements			
Minimum:	9 kVA	9 kVA	9 kVA
Recommended:	12 kVA	12 kVA	12 kVA
Power Consumption			
Cool Down max. 50/60 Hz:	7.2/8.3 kW 6.5/7.5 kW	7.2/8.3 kW 6.5/7.5 kW	7.2/8.3 kW 6.5/7.2 kW
Steady State max. 50/60 Hz:			
Water supply to remove the heat load (cooling power > 8.3 kW):	Flow: 420 l/hour Temperature: 4-28°C Water Quality: PH 6.5-8.2 Hardness: mg[CaCo3]/l < 200 Molybdate-reactive silicate: < 50 mg/l Suspended matter: < 10 mg/l Maximum pressure: < 7 bar (100 PSI)		---
Helium Gas Supply:	A high purity helium (He) gas cylinder (6 N = 99.9999% or better, maximum impurity concentration 1 ppm).		
Acoustic Noise:	Maximum 60 dB(A), 2 meters distant.		
Ambient Operating Temperature:	5 to 28°C (41 to 82.4°F)		30°C

Table 10.2: Technical Data for Indoor Compressors

## 10.2.2.2 Outdoor Helium Compressors

The outdoor helium compressor has an outdoor and an indoor unit. Each component has space requirements for airflow and servicing. The indoor component requires a space of 0.5 m (width) x 1.3 m (depth) x 1 m (height) and the outdoor component requires a space of 1.4 m (width) x 1.7 m (depth) x 1.25 m (height).

Sumitomo Type:	CNA-61C		CNA-61D
Type of Compressor:	Air		Air
Dimension:	Width: 91 cm Depth: 405 cm Height: 105 cm	Width: 27 cm Depth: 575 cm Height: 63 cm	Width: 91 cm Depth: 40 cm Height: 105 cm
Weight:	115 kg	45 kg	115 kg
Voltage:	3 x 200 V		3 x 400 V
Mainly delivered to:	USA/CA/JP		EU/CH
Operating Current:	27 A		13 A
Minimum Circuit Am- pacity:	50 A		30 A

Sumitomo Type:	CNA-61C		CNA-61D
Maximum Fuse/Circuit Breaker Size:	50 A		30 A
Compressor LRA:	156 A		74 A
Power Requirements			
Minimum:	11 kVA		11 kVA
Recommended:	14 kVA		14 kVA
Power Consumption			
Cool Down max. 50/60 Hz:	8.0/9.2 kW 7.5/8.5 kW		8.0/9.2 kW 7.5/8.5 kW
Steady State max. 50/60 Hz:			
Acoustic Noise:	Maximum 66 dB(A), outdoor unit only.		
Ambient Operating Temperature:	-30 to 45°C (-22 to 113°F)	5 to 28°C (41 to 82.4°F)	-30 to 45°C (-22 to 113°F)

Table 10.3: Technical Data for Outdoor Compressors

## 10.3 Helium Cylinders

The next step in the site planning for a CryoProbe accessory involves determining the location for the helium gas cylinder. A research grade helium cylinder (grade 6.0, 99.9999%) is supplied by the customer and is connected to the CryoCooling unit. The cylinder must be outside the 5 Gauss line in a serviceable location (i.e. changing the bottle should not interfere with nearby magnets). The helium regulator is supplied by Bruker.

Two lengths of helium gas line are available (10 m and 20 m).

The helium compressor and helium gas cylinder may be sited in a remote room or in the same room as the spectrometer as shown in the layout examples.

## 10.4 Summary of CryoProbe Options

### Helium Compressors (3 Options)

- Indoor Air Cooled
- Indoor Water Cooled
- Outdoor Air Cooled

### Helium Gas Transfer Lines

#### For Indoor Helium Compressors (3 Options)

- 6 m
- 10 m
- 20 m

#### For Outdoor Helium Compressors (11 Options)

- 3 m indoor line / 10 m outdoor line
- 3 m indoor line / 20 m outdoor line
- 3 m indoor line / 30 m outdoor line
- 6 m indoor line / 10 m outdoor line
- 6 m indoor line / 20 m outdoor line
- 6 m indoor line / 30 m outdoor line
- 10 m indoor line / 10 m outdoor line
- 10 m indoor line / 20 m outdoor line
- 10 m indoor line / 30 m outdoor line
- 20 m indoor line / 10 m outdoor line
- 20 m indoor line / 20 m outdoor line

## Helium Cylinder High Pressure Gas Line (2 Options)

- 10 m
- 20 m

## Helium Transfer line from CryoCooling Unit to CryoProbe

- A standard length transfer line, determined by the magnet, is delivered with each CryoPlatform. Longer transfer lines may be ordered if necessary to accommodate the CryoCooling unit in your laboratory. If a longer transfer line is required a special review of your site will be required.

## CryoPlatform

### CryoCooling Unit

- Located outside 50 Gauss (5 mT) line.
- Must be serviceable from all sides.
- Must be at least 0.5 meters from walls on all sides.

### Helium Compressor- Indoor Water or Air Cooled

- Located outside 5 Gauss line.
- Minimum room space is 1.25 m (width) x 0.8 m (depth) x 0.7 m (height).
- Must be serviceable from top and left side.
- The distance between the CryoCooling unit and the helium compressor component is defined by the helium transfer lines ordered.
- Chilled water lines must be supplied to helium compressor (water cooled unit only).
- Ambient operating temperature 5°–28°C.



### Note:

The indoor helium compressor has rollers and is connected to flexible helium transfer lines. Water-cooled models are additionally connected to water lines supplied by the customer (typically high pressure flexible water tubing).

---

## **Helium Compressor - Outdoor Air Cooled**

- Consists of one small indoor unit, one outdoor unit, and transfer lines connecting the units.
- Requires indoor space of 0.5 m (width) x 1.3 m (depth) x 1 m (height).
- Requires outdoor space of 1.4 m (width) x 1.7 m (depth) x 1.25 m (height).
- The distance between the CryoCooling unit and the two helium compressor components is defined by the transfer lines ordered.
- Ambient operating temperature for outdoor components is -30–45°C.

## **Helium Cylinder**

- The distance between the CryoCooling unit and the helium cylinder is defined by the gas line ordered.
- Must be in a serviceable location (to change cylinder and not interfere with magnet).



# 11 Installation

Please fill out and return the Site Planning Checklist prior to the delivery of the magnet system. If this checklist was not provided, please contact your Bruker representative immediately.

All general requirements such as power supply, compressed air supply, etc. must be installed before the system can be delivered. Installation requirements such as cryogen supplies are totally separate from normal operation requirements. The system can only be delivered and installed after the completion of all construction work in the lab. The lab must be cleaned from all remaining dirt, dust, particles, etc.

The magnet transport crates should be kept indoors out of direct sunlight. The crates should not be opened until a Bruker magnet engineer arrives. Failure to do so may invalidate the warranty. The crates are shipped with Shockwatch™ and Tiltwatch™ indicators.

## 11.1 Overview

The spectrometer system will arrive at the site in crates. The crates should only be opened by the Bruker BioSpin service engineer. The commissioning of the magnet involves several stages as outlined in the table below. The installation timeline given below is an approximation; each site is slightly different.

Duration	Procedure
ca. 3-8 hours	Transport fixtures are removed. Cryostat is assembled.
2-4 days	The magnet is evacuated and flushed through with nitrogen.
1-3 days	Cool down of the magnet with liquid nitrogen.
1 day	Cool down of the magnet with liquid helium.
1-2 days	Charging of the magnet.
1 day	Cryo-shimming of the magnet.

Table 11.1: Overview of Magnet Commissioning

## 11.2 Accessibility

Before the arrival on site, the customer must ensure the equipment can be delivered, and transported safely to the final location inside the NMR room. Please refer to Magnet Access and Rigging [▶23] for details.

## 11.3 Installation Requirements Checklist

---

For the installation the customer must provide the following:

- Lifting equipment and minimum ceiling height as outlined in the table in Sub-cooling and Charging the Magnet [▶ 91]. Pallet jack and/or fork lift for transporting system accessories.
- A cylinder of N<sub>2</sub> gas 50l/200 bar (~2 cu.ft, 3000 psi) with reducing regulator valves to deliver pressure of 0.5 bar (~8 psi), as specified in Compressed Gas Specifications [▶ 57].
- A cylinder of He gas 50l/200 bar (~2 cu.ft, 3000 psi) with reducing regulator valves to deliver a pressure of 0.2 bar (~3 psi), as specified in the section Compressed Gas Specifications [▶ 57].
- Quantities of liquid helium and nitrogen as specified in the table in Sub-cooling and Charging the Magnet [▶ 91].
- Liquid helium and nitrogen transport dewars as specified in Compressed Gas [▶ 56].
- One power outlet 230V/16A (USA 208V/30A) single phase and two more 230V/16A (USA 208V/20A) single phase power outlets are needed to run a vacuum pump, a heat gun, and a power supply unit. These power outlets must be available in addition to the main power source used to run the spectrometer.
- Minimum two standard doublet outlets 230V/16A (USA 110V/20A); ideally, these should be plentiful around the laboratory.
- Step ladder (non-magnetic e.g. aluminum, fiberglass, or wood).

Where possible the customer should provide the following:

- Heat gun or hand held hair dryer (min. 1200 W).
- Roughing pump 10<sup>-2</sup> mbar (14.5 x 10<sup>-5</sup> psi).
- Pair of insulated gloves.
- Electric screwdriver.

## 11.4 Installation Procedure

---

The various steps and procedures mentioned in the Overview [▶ 89] will be discussed in detail in the following sections.

### 11.4.1 Magnet Assembly

---

Once the magnet is lifted off the delivery truck using a suitable overhead crane, it can be transported to the magnet room with a pallet jack.

An A-Frame or a fixed lifting hook must be provided to lift the magnet for assembly. The assembly area should be clean, dry and free of dust. Under certain circumstances, lifting equipment may be provided by Bruker. The table found in Sub-cooling and Charging the Magnet [▶ 91] lists the minimum ceiling height, minimum hook height, and the weight for each magnet.

When arranging suitable lifting gear, the customer is asked to ensure that the lifting gear has been certified to lift the weight required.

#### See also

- 📄 Overview [▶ 89]

### 11.4.2 Magnet Evacuation and Flushing with Nitrogen Gas

---

Once the magnet has been assembled and placed in the magnet room, rough pumping of the cryostat can begin. At the same time the cryostat is flushed through with dry nitrogen gas. The customer must provide a 50l/200 bar (~2 cu.ft, 3000 psi) cylinder of dry nitrogen gas (99.9999% purity). The cylinder should be fitted with a secondary regulator valve to deliver a pressure of 0.5 bar (~8 psi).

For some installations the customer is asked to provide a roughing pump, e.g. rotary pump capable of reducing pressures within the cryostat to  $10^{-3}$  mbar. Further pumping of the cryostat is then carried out to reduce the internal pressure to  $10^{-6}$  mbar. It is convenient, if the customer can provide a suitable pump such as a diffusion or turbo pump. If such a pump is available the customer should contact Bruker Biospin to confirm its suitability. Where no such pump is available then it will be supplied by Bruker.

### 11.4.3 Cooling the Magnet to Liquid Nitrogen Temperatures

---

This next stage involves filling the magnet with liquid nitrogen. The quantity of liquid nitrogen required is listed in the table in the Overview [▶ 89]. The transfer dewars used for precool generally have a capacity of 250 - 500 liters with a fixture for pressuring and transferring via a stainless steel or corrugated plastic tube of 10 mm (~3/8") diameter.

### 11.4.4 Cooling the Magnet to Liquid Helium Temperatures

---

For this procedure, the customer must provide the following:

- A cylinder of helium gas: 50l/200 bar (~2 cu.ft, 3000 psi), 99.996%, with secondary regulator valve to deliver pressure of max 0.2 bar (~3 psi).
- Quantities of liquid helium as specified in the table found in the Overview [▶ 89].
- Liquid helium dewar: 250 - 500 liter capacity, with NW25 flange or suitable outlet compatible with the 10 mm (~3/8").

When ordering the helium the customer should arrange to have it delivered immediately before cooling the magnet to liquid helium temperature. If delivered to the site much earlier, losses due to evaporation will occur and must be taken into account (usually 1% of nominal volume/day).

### 11.4.5 Sub-cooling and Charging the Magnet

---

The final stage involves sub-cooling the magnet to reduced temperature (~4K) and bringing the magnet to field. During the charging there is a possibility for the magnet to experience a quench. The quantities of liquid helium for final cool down and energization/cryoshimming as well as extra liquid helium required after one quench are specified in the table below. The customer is required to provide the cryogenes needed for the complete installation including up to two training quenches.

The values of liquid nitrogen and helium in the table below are the minimum requirements. An extra 20-30% of each is advisable, particularly as many suppliers will take back unused cryogenes.

## Installation

Magnet Type	Magnet Weight Empty with Magnet Stand (kg)*	Magnet Weight Filled with Magnet Stand (kg)	LN2 Needed for Pre-cool (l)	LHe Needed for Cool-down and Charging (l)	LHe After a Training Quench (l)
200 MHz/154 mm US PLUS LH	649	780	480	200	100
300 MHz/54 mm US LH	242	292	150	150	50
300 MHz/54 mm Fourier US LH	242	292	150	150	50
300 MHz/54 mm Ascend ULH (standard/optional stand)	311/399	411/499	300	200	100
300 MHz/89 mm Ascend (standard/optional stand)	382/470	540	600	400	150
300 MHz/154 mm US PLUS LH	649	780	480	200	110
400 MHz/54 mm Ascend (standard/optional stand)	417/505	484/572	400	200	100
400 MHz/54 mm Ascend ULH (standard/optional stand)	437/525	532/620	500	300	150
400 MHz/54 mm Ascend RS (stand/cooler/flexline)	~524	548	400	400	150
400 MHz/89 mm Ascend (standard/optional stand)	593/681	682	600	400	150
400 MHz/89 mm Ascend DNP	681	850	600	400	150
400 MHz/154 mm US PLUS LH	1700	2000	900	600	300
500 MHz/54 mm Ascend (standard/optional stand)	472/560	650/740	400	200	100
500 MHz/54 mm Ascend ULH	1025	1050	600	400	150
500 MHz/54 mm Ascend RS (stand/cooler/flexline)	~623	675	400	400	150
500 MHz/89 mm Ascend	698	770	600	400	150
500 MHz/154 mm US PLUS LH	1700	2000	900	600	300
600 MHz/54 mm Ascend	730	850	500	300	160
600 MHz/54 mm Ascend ULH	1158	1435	850	600	400
600 MHz/89 mm Ascend	1235	1446	750	500	250
600 MHz/89 mm Ascend DNP	1235	1446	750	500	250
700 MHz/54 mm Ascend	1235	1446	750	500	250
750 MHz/54 mm Ascend	~1626	~1874	850	600	400
750 MHz/89 mm Ascend	~2568	~2908	1700	1600	700
LH = Long Hold, ULH = Ultra Long Hold					
The weights of the accessories are approximations. The actual weight may vary depending on the options and accessories that are ordered.					
* For standard stand, weight will vary with optional stands.					

*Table 11.2: Magnet Transport Weights*

**See also**

 [Overview \[▶ 89\]](#)



## Figures

Figure 2.1:	Stronger Stray Fields in Vertical Direction than in Horizontal Direction .....	9
Figure 3.1:	Spectrometer and Magnet Control .....	18
Figure 3.2:	CryoProbe System .....	19
Figure 3.3:	CryoProbe Prodigy with Pump and Control Unit .....	20
Figure 3.4:	Other Options for AVANCE Systems .....	21
Figure 4.1:	Unloading the Magnet .....	24
Figure 5.1:	A-Frame Gantry for Lifting the Magnet Inside the Magnet Room .....	33
Figure 5.2:	Ceiling Height Requirements .....	34
Figure 5.3:	Helium Transfer Lines .....	35
Figure 6.1:	Example of a Stray Field Plot 750 MHz/89 mm Ascend .....	42
Figure 7.1:	Example of Vibration Damping Isolators .....	44
Figure 8.1:	Example of a Typical Dryer/Filter System Setup .....	58
Figure 8.2:	Emergency Quench Pipes .....	66
Figure 9.1:	Magnet Dimensions .....	70
Figure 9.2:	Example of a Simple Magnet Platform .....	73
Figure 9.3:	Example of a Magnet Pit .....	74
Figure 9.4:	AVANCE 400 MHz Example Layout .....	77
Figure 9.5:	AVANCE 600 MHz Example Layout .....	78
Figure 10.1:	CryoProbe System Overview .....	80
Figure 10.2:	Helium Compressor - Indoor Water Cooled .....	82
Figure 10.3:	Helium Compressor - Indoor Air Cooled .....	82
Figure 10.4:	Helium Compressor - Outdoor Air Cooled .....	83



## Tables

Table 1.1:	Metric to American Conversion Factors .....	7
Table 2.1:	BGV B11 Standards for Standard Precautions and Users.....	11
Table 2.2:	BGV B11 Standards Under Special Conditions for Selected Subgroups.....	11
Table 2.3:	Example of Maximum Retention Periods .....	11
Table 4.1:	Door Dimensions for Magnet Access .....	25
Table 4.2:	Door Dimensions for Magnet Stand & Accessories Access .....	26
Table 4.3:	Magnet Transport Weights .....	28
Table 4.4:	Door Dimensions for Magnet Room Access: Spectrometers .....	29
Table 4.5:	Crate Dimensions for Accessories .....	29
Table 4.6:	Transport Weights of NMR Cabinets and Accessories.....	30
Table 5.1:	Helium Transfer Line Dimensions.....	35
Table 5.2:	Ceiling Height Requirements.....	36
Table 6.1:	Effects of Magnetic Fields on Equipment .....	39
Table 6.2:	Horizontal Stray Fields of Various Magnets.....	40
Table 6.3:	Horizontal Stray Fields of Various Magnets.....	41
Table 7.1:	Vibration Damping Options.....	45
Table 7.2:	Recommendations for Static Magnetic Objects.....	47
Table 7.3:	Recommendations for Moveable Magnetic Objects.....	48
Table 7.4:	Minimum Distances from Sources of DC EMF Interference.....	49
Table 7.5:	List of Most Commonly Studied Nuclei and Corresponding Resonance Frequencies .....	51
Table 8.1:	Requirements of Basic System (2 Channels).....	54
Table 8.2:	CryoProbe System Utility Requirements .....	55
Table 8.3:	Compressed Gas Requirements .....	57
Table 8.4:	Heat Generated by Typical AVANCE Systems.....	63
Table 8.5:	Maximum Helium Capacity and Gas Flow Rate .....	64
Table 9.1:	Dimensions and Weights of NMR Equipment .....	69
Table 9.2:	Magnet Dimensions and Total Weights .....	71
Table 9.3:	Maximum Field Strength for NMR Equipment.....	75
Table 10.1:	CryoCooling Unit Specifications .....	81
Table 10.2:	Technical Data for Indoor Compressors .....	83
Table 10.3:	Technical Data for Outdoor Compressors .....	84
Table 11.1:	Overview of Magnet Commissioning .....	89
Table 11.2:	Magnet Transport Weights .....	92



# Glossary

## **BMPC**

---

Bruker Monitoring and Pump Control Unit

## **IconNMR**

---

IconNMR is the data acquisition software available for AVANCE systems, that provides an easy-to-use software interface for common  $^1\text{H}$  and  $^{13}\text{C}$  experiments in a range of common NMR solvents.

## **Quench**

---

A magnet quench is the breakdown of superconductivity in a partially or fully energized magnet. The stored field energy is transformed into heat, leading to a fast evaporation of liquid helium. During a quench, an extremely large quantity of helium gas (i.e. 43 m<sup>3</sup> to 595 m<sup>3</sup> depending on the magnet type) is produced within a short time. Although these gases are inert, if generated in large enough quantities, they can displace the oxygen in the room causing potential danger of suffocation. Although these gases are inert, if generated in large enough quantities, they can displace the oxygen in the room causing potential danger of suffocation.

## **SampleTrack**

---

SampleTrack is a BRUKER laboratory automation and management system with a standardized interface for BRUKER spectrometers. As a software tool for the laboratory network, SampleTrack manages all automation process steps in an analytical environment.

## **SCFM**

---

Standard Cubic Feet per Minute

## **TopSpin**

---

TopSpin™ is our software package for acquisition, processing and analyzing NMR data, streamlined for your convenience. TopSpin was designed for Windows® and Linux® users with a highly intuitive interface utilizing the most widespread standards familiar from word processing, graphics, or presentation programs, providing the same look-and-feel for your NMR applications.



# Index

## A

Air compressor .....	18
Air conditioning .....	48
Airplanes .....	43
Automobiles .....	43
AVANCE Cabinet	
Dimensions and weight.....	69

## B

B-CU-I	
Dimensions and weight.....	69
BCU-I cooling unit .....	56, 58
BCU-I Unit.....	18
BCU-II	
Dimensions and weight.....	69
BCU-II cooling unit.....	58
BCU-II Unit.....	18
BMPC	
Dimensions and weight.....	69
BMPC II.....	18
Breathing equipment.....	16
BSNL.....	21
Buffer containers .....	58

## C

Centrifuges.....	48
Compressors.....	43
Concrete floors.....	72
Constant flow rate .....	59
Construction sites .....	43
CP-MAS .....	53
Crane .....	31
Crates .....	25
Cryogen	
Transport dewars .....	14
Cryogen maintenance.....	61
Cryogenic liquids.....	13
Storage containers .....	13
Cryogenics	

Boil-off of liquids .....	12
Cryogenic gas to liquid volume ratios.....	12
High pressure gas-packs.....	14
Safe handling of cryogenic liquids .....	13

## D

D.C. operated elevators, trains .....	48
DC EMF .....	49
Dewars.....	76
Digital Lock .....	49

## E

Earthquakes.....	15
Electric motors .....	48
Electrical outlets.....	76
Electrostatic Discharge .....	72
Elevators.....	14, 48
Emergency access .....	16
Emergency Plan .....	15
ESD resistant flooring .....	72

## F

Fans.....	43
Faraday cage.....	51
Ferromagnetic materials .....	46
Ferromagnetic objects .....	9, 10
Fire extinguishers .....	16
Floor Types	
PVC .....	72
Vinyl.....	72
Wood .....	72
Fluxgate magnetometer.....	49
Fork Lift.....	31

## G

Gas cylinder.....	14
Gas cylinder storage.....	76
Generators.....	43

## H

He fill port.....	72
-------------------	----



SampleCase .....	21
SampleJet.....	21
SampleXpress.....	21
Satellite systems .....	50
Service access	
Magnet.....	76
Spectrometer .....	76
Solid Impurities .....	58
Standard Operating Procedures .....	15
Subways .....	48
Sunlight.....	72
Support beams.....	72

## T

Television broadcasts.....	50
Trains .....	43
Trams .....	48
Transformers.....	48
Transportation	
Overhead crane .....	24

## U

UPS.....	53
Dimensions and weight.....	69

## V

Ventilation	
Emergency ventilation.....	12
HVAC systems .....	12
When using a magnet pit.....	73
Vibration	
Guidelines .....	43
Vibration dampers .....	43
Vibrations .....	43
Voltage stabilizer .....	53
VT gas.....	18

## W

Water Content: .....	58
Wooden floors .....	72
Workstation	
Dimensions and weight.....	69





**End of Document**



[www.bruker.com](http://www.bruker.com)



## Installation Questionnaire NMR-Spectrometers

Customer Information					
<b>Customer Name</b> (Responsible Person)					
<b>Company / Institution</b>					
<b>Address/ Street/ Building/ Room</b>					
<b>Postal Code/ Town</b>					
<b>Phone</b>		<b>FAX</b>			
<b>E-mail</b>					
<b>Contract No.</b>		<b>Order No.</b>		<b>Spectrometer</b>	
The site is prepared as recommended in the "Site Planning Guide" and ready for the spectrometer installation commencing at				Date: _____	
<b>Main Field of Laboratory Research:</b>					
<b>Special Agreements or Conditions</b>	No    If yes, please specify: _____				
<b>Will the NMR system be equipped with</b> (additional Questionnaire necessary):	Cryo Probe	BSNL	Imaging Cryo Probe		
	Other: _____				
Safety Precautions					
<b>Will the access to your NMR laboratory be restricted to authorized and qualified personnel only?</b>	Yes				No
<b>When not, can the area around the fringe field of the magnet system be blocked or roped?</b>	Yes				No
<b>Are the emergency exits defined and marked?</b>	Yes				No
<b>What is the air exchange rate in the NMR Laboratory?</b> <small>(Minimum requirement 3 times the room volume per hour)</small>	Exchange rate (approx.): _____ m <sup>3</sup> /hour				
<b>In case of a hazard (magnet quench) are there over pressure exhaust systems installed?</b> (With the site planning manual there are worst case volumes for each magnet system available)	Yes				No
<b>Are Oxygen level meters installed in the NMR laboratory?</b>	Yes , how many: _____				No
<b>Are there smoke detectors installed?</b>	Yes				No
	Distance to the designated place for the magnet system: _____ m				
<b>Is there sprinkler system installed?</b>	Yes				No
	Distance to the designated place for the magnet system: _____ m				
<b>Are the local maintenance staff and authorities (fire department) introduced to the possible risks of a magnet system?</b>	Yes				Not yet



<b>Loading Deck / Access to the Installation Site</b>	
Will the system be offloaded at the central loading dock?	Yes <span style="float: right;">No</span>
Will the system be stored in a dry and air conditioned room?	Yes <span style="float: right;">No, but &lt;35 ° C, &lt; 80 % humidity</span> No
Description of the transportation route to the laboratory and equipment available to shift the boxes (forklift / pallet lifter / hoist of suitable capacity)	Flat route: Yes <span style="float: right;">No</span> Ramp (grade): _____ Transportation device: _____
Can all transportation operations be carried by one or two persons?	Yes <span style="float: right;">No</span>
What is the minimum height and width on the route to the lab (door dimensions)?	Height: _____ Width: _____
Is there an elevator needed on the route?	No Yes, Capacity: _____ kg Dimensions: _____ Width: _____ Height: _____ Depth: _____
What is the minimum floor capacity on the route?	Floor Capacity (approx.): _____ kg / m <sup>2</sup>
Does the access route floor have any sufficient load bearing capacity without special measures?	Yes <span style="float: right;">No</span>
Is the access route from offloading area to the installation site negotiable with standard load handling equipment?	Yes <span style="float: right;">No</span>
Laboratory entrance?	Minimum opening width: _____ m Minimum door height: _____ m
Is there anything else to be known for unloading and transportation to the laboratory?	_____ _____ _____
<b>Site Preparation</b>	
Because of floor vibrations, on which floor level will the NMR system be installed?	_____
Are some big machines, air conditioning systems, elevators nearby?	Yes, distance: _____ m <span style="float: right;">No</span>
Are other NMR systems already installed in the neighborhood?	Yes <span style="float: right;">No</span>
Floor Vibration	Very likely <span style="float: right;">Not likely</span> Vibration Survey needed
Is the Laboratory air-conditioned? <small>(Recommended room temperature 17-25 °C variation not more than 2°C per 24 hour for systems up to 400 MHz and 1°C &gt; 500 MHz)</small>	No Yes <span style="float: right;">ducted local</span> Capacity _____ kW Temperature stability _____ °C per 24 hour ; Humidity _____ %
During Helium and Nitrogen refills can the air conditioning system be manually increased to a higher exchange rate?	Yes <span style="float: right;">No</span>



**Report**

**Site Planning**

<p><b>Will the air conditioning system be regulated (activated with only fresh air) by a low Oxygen level?</b></p>	<p><b>Yes</b> <span style="float: right;"><b>No</b></span></p>
<p><b>Has the floor any ESD (Electrostatic Discharge) Prevention's?</b></p>	<p><b>No</b></p> <p>If yes, please specify: _____</p>
<p><b>Do you anticipate any source of magnetic or radio frequency interferences</b> (Elevators, Trams, Subways, Mass Spectrometer, R.F. Transmitters, Radio and/or TV Towers, other NMR Systems)</p>	<p><b>No</b></p> <p>If yes, please specify: _____</p> <p>Distance: _____</p> <p><b>EMF Survey needed</b></p>
<p><b>Magnet fringe field – does the 0.5 mT ( 5 Gauss) line extend into adjacent rooms (around, above and below)</b></p>	<p><b>No</b></p> <p>If yes please specify:</p> <p><b>Survey needed</b></p>
<p><b>Presence of ferromagnetic materials</b></p>	<p><b>No</b></p> <p>Yes, static: approx. Mass _____kg approx. distance: _____m</p> <p>Yes, movable: approx. Mass _____ kg approx. distance: _____m</p> <p>Further details: _____</p>
<p><b>Line Voltage</b> (Line voltage fluctuation &lt; -10% to +5%)</p> <p><b>Has an additional separate ground connector been provided?</b></p> <p><b>Do you have a line voltage stabilizer/UPS for the complete NMR system?</b></p>	<p><b>1x230 V</b> (plus Neutral and Ground), <b>16 A slow, 50Hz for Avance Two Bay and smaller</b></p> <p><b>3x400 V</b> (plus Neutral and Ground), <b>16 A slow, 50Hz for Avance Two Bay with Extension</b></p> <p><b>3x200 V, 60 Hz</b></p> <p>Other _____</p> <p><b>Yes</b> <span style="float: right;"><b>No</b></span></p> <p>Yes _____ kVA, Brand: _____</p> <p><b>No, but for the computer:</b></p> <p>_____ kVA Brand: _____</p> <p><b>No</b></p>
<p><b>Is compressed gas supply Nitrogen or oil free Air?</b> (Oil &lt; 0.005 ppm/ 0.005 mg/m<sup>3</sup>)</p> <p><b>Does the gas supply meet the flow rate and pressure requirements for the system as outlined in the Avance Site Planning Guide?</b> (Minimum required pressure 6 bar)</p> <p><b>Are suitable filters installed in the compressed gas supply lines?</b> (Solid impurity: HR-NMR 5 micron / MAS 1 micron filters)</p>	<p><b>Nitrogen</b> <span style="float: right;"><b>Oil free air</b></span></p> <p><b>Yes</b> <span style="float: right;"><b>No</b></span></p> <p><b>Yes</b> <span style="float: right;"><b>No</b></span></p>



<b>Report</b>	<b>Site Planning</b>
---------------	----------------------

<b>If compressed air is to be used, is a dryer installed to achieve a suitable dew point?</b> (-50C for BCU, -100C for BCU-X, dryers with switching columns should have a buffer tank located after)	Yes	No
<b>If compressed air is to be used, is a Nitrogen separator available or included in the order?</b> (Use of Nitrogen is mandatory for HR-NMR at and above 500 MHz)	Yes	No
<b>Will any other accessories or devices utilizing compressed gas supply be connected to the system?</b> (i.e. sample changer, MAS unit, cryo probe)	Yes	Details: _____
	No	

<b>Installation Preparation</b>
---------------------------------

<b>Room Dimension</b>	Length: _____ m Width: _____ m
<b>Ceiling height in Magnet area</b>	Ceiling height: _____ cm
<b>Is a ceiling hook available above final position for magnet assembly?</b>	Yes, hook height: _____ cm, loading capacity: _____ kg
<b>No</b>	<b>No</b>
<b>If ceiling hook is not available, has a suitable hoist for lifting the magnet for assembly been organized or shall Bruker provide the hoist?</b> (100-500 MHz min. 700kg) (>500 WB, 600 MHz min. 1200 kg)	Yes <b>No Bruker shall organize a hoist</b>
	<b>Yes. Is there enough space for a 2.5 m long hoist beam?</b>
	<b>No Site Survey needed</b>

<b>Cryogenic Liquids Supply</b>
---------------------------------

<b>Liquid Nitrogen /Size of storage vessel</b> (100-500 MHz approx. 250 litre) (>500 WB and 600NB: 600 litre) <b>See magnet specifications for details</b>	Liquid Nitrogen: _____ litre available Size of storage vessel: _____ litre
<b>One He Gas cylinder available</b> (approx. 50 litre/ 200 bar) including regulator (for 600 MHz and above 2 cylinders!)	<b>No</b> <b>Yes</b>
<b>Liquid Helium if not supplied by BRUKER and size of storage vessels</b> (see magnet specifications for details)	Liquid Helium: _____ litre Size of storage vessel: _____ litre

<b>Training requirements</b>
------------------------------

<b>Has operating personnel experience with other BRUKER NMR Instruments?</b>	<b>No</b> <b>Yes models:</b>
<b>Have any special training arrangements been discussed?</b>	<b>No</b>  <b>If yes please specify:</b>

<b>Additional information required in case of a spectrometer relocation</b>
---

<b>In accordance with the contract the following probe(s) has to be shimmed</b>	
---	--



**Report**

**Site Planning**

Hump test spectrum of the above specified probe was acquired and spectra are attached	No Yes
<b>Signature</b>	
Customer name (responsible person)	Date Signature

*Please note that incomplete or false statements leading to extended installation times or require rescheduling of the installation may have to be invoiced according to the local service rates.*