

AVANCE

- Site Planning for AVANCE Systems 800-950 MHz
User Guide
Version 007



Copyright © by Bruker Corporation

All rights reserved. No part of this publication may be reproduced, stored in a retrieval system, or transmitted, in any form, or by any means without the prior consent of the publisher. Product names used are trademarks or registered trademarks of their respective holders.

This manual was written by

Razvan Teodorescu and Stanley Niles

© Friday, January 18, 2013 Bruker Corporation

P/N: Z31686

DWG: 1453007

For further technical assistance for this product, please do not hesitate to contact your nearest BRUKER dealer or contact us directly at:

Bruker Corporation
am Silberstreifen
76287 Rheinstetten
Germany
Phone: + 49 721 5161 0
FAX: + 49 721 5171 01
E-Mail: nmr-support@bruker.de
Internet: www.bruker.com

Contents

1	Introduction	7
1.1	Units Used Within This Manual	7
2	Safety	9
2.1	The Magnetic Field	9
2.1.1	Exclusion Zone	10
2.1.2	Security Zone	10
2.1.3	Standards on Health and Safety in the Workplace	10
2.2	Ventilation	12
2.2.1	Regular Ventilation	12
2.2.2	Emergency Ventilation	13
2.2.3	Oxygen Level Sensors	13
2.3	Safe Handling of Cryogenic Substances	13
2.3.1	Refill of Liquid Nitrogen	14
2.3.2	Refill of Liquid Helium	14
2.4	Earthquake Safety	15
2.5	Country-Specific Safety Regulations	15
2.6	Emergency Planning	15
2.6.1	Fire Department Notification	16
3	Equipment	17
3.1	Superconducting Magnet Components	17
3.2	Console and Other System Components	18
3.3	CryoProbe System (Optional)	19
3.4	Other Optional Components	20
4	Magnet Access and Rigging	21
4.1	Considerations for Off-loading on Site	21
4.2	Considerations for Transport to the NMR Room	22
4.3	Transport Dimensions and Weights	23
4.3.1	Magnet Transport Dimensions	23
4.3.2	Magnet Transport Weights	23
4.3.3	Spectrometer and Accessories Weights	24
4.4	Rigging Equipment	24
5	Ceiling Height Requirements	27
5.1	Helium Transfer Line	29
5.2	Minimum Ceiling Height	30
6	Magnetic Stray Fields	31
6.1	Horizontal Stray Fields	31
6.2	Vertical Stray Fields	32
6.3	Stray Field Plots	33
7	Environment and Site Survey Measurement	39
7.1	Vibrations	39
7.1.1	Vibration Guidelines	39
7.2	Magnetic Environment	40
7.2.1	Guidelines for Static Objects	40
7.2.2	Guidelines for Moving Objects	41
7.3	Electromagnetic Interference	41

7.3.1	Types of EMF Interference	41
7.3.2	DC EMF Interference.....	41
7.3.2.1	Measuring DC Fluctuating Fields	42
7.3.2.2	Guidelines for DC Interference	42
7.3.2.3	Reducing DC Interference	42
7.3.3	16-2/3 Hz and 50/60 Hz EMF Interference	43
7.3.3.1	Measuring 16-2/3 Hz and 50/60 Hz Fluctuating Fields.....	43
7.3.3.2	Guidelines for 16-2/3 Hz and 50/60 Hz Interference	43
7.3.3.3	Reducing 16-2/3 Hz and 50/60 Hz Interference	43
7.3.4	RF Interference.....	44
7.3.4.1	Measuring RF Fluctuating Fields.....	44
7.3.4.2	Most Commonly Studied Nuclei.....	44
7.3.4.3	Guidelines for RF Interference	44
7.3.4.4	Reducing RF Interference	45
8	Utility Requirements	47
8.1	Electrical Power Requirements	47
8.2	Telecommunication.....	49
8.3	Compressed Gas.....	49
8.3.1	General Requirements	49
8.3.2	Gas Supply	50
8.3.3	Other Specifications.....	50
8.3.4	Compressed Air System.....	51
8.3.4.1	Air Compressors.....	52
8.3.4.2	Dryers	52
8.3.4.2.1	Refrigeration Dryers	52
8.3.4.2.2	Absorbtion Dryers.....	53
8.3.4.3	Filters.....	53
8.4	Water	54
8.5	Lighting	54
8.6	HVAC (Heating Ventilation Air Conditioning)	54
8.6.1	Heat Output	55
8.6.2	System Stability	55
8.7	Emergency Ventilation During Installation and Quenches.....	56
8.7.1	Emergency Exhaust Solutions.....	57
8.8	Fire Detection System and Fire Extinguishers	58
9	Floor Plan	59
9.1	Size and Mass of Equipment.....	59
9.1.1	Magnet Dimensions	60
9.1.2	Magnet Dimensions and Total Weight	61
9.2	Magnet Location	61
9.3	Floor Load	62
9.3.1	Magnet Slab	63
9.4	Floor Types.....	64
9.5	Magnet Platform	64
9.6	Magnet Pits.....	66
9.7	Magnet Pump Line	66
9.8	Maximum Field Strengths for NMR Equipment	67
9.9	Automation Considerations	67

9.10	Cabinet Position	67
9.11	Worktable Position.....	68
9.12	Service Access Requirements.....	68
10	CryoProbe and Other Accessories	73
10.1	CryoCooling Unit	75
10.2	Helium Compressors	75
10.2.1	Available Models	75
10.2.1.1	Helium Compressor - Indoor Water Cooled	76
10.2.1.2	Helium Compressor - Indoor Air Cooled.....	76
10.2.1.3	Helium Compressor - Outdoor Air Cooled.....	77
10.2.2	Space Requirements and Specifications	77
10.2.2.1	Indoor Helium Compressors.....	77
10.2.2.2	Outdoor Helium Compressors	78
10.3	Helium Cylinders	79
10.4	Summary of CryoProbe Options.....	79
11	Installation	83
11.1	Overview.....	83
11.2	Accessibility.....	83
11.3	Installation Requirements Checklist	84
11.4	Installation Procedure.....	84
11.4.1	Magnet Assembly	84
11.4.2	Magnet Evacuation and Flushing with Nitrogen Gas.....	85
11.4.3	Cooling the Magnet to Liquid Nitrogen Temperatures	85
11.4.4	Cooling the Magnet to Liquid Helium Temperatures.....	85
11.4.5	Charging the Magnet.....	85
	List of Figures	87
	List of Tables	89
	Glossary	91
	Index	93

1 Introduction

This manual contains information about site planning and preparation prior to delivery of a Bruker AVANCE system. The manual should be read through carefully as mistakes made initially may be costly to remedy at a later stage.

The systems covered by this manual are AVANCE spectrometers in the range of 800-950 MHz. A **separate manual** is available for 300-750 MHz systems.

The chapters within this manual deal with various points that need to be considered for successful system operation. They have been included to familiarize you with general principles of successful site planning. For specific questions that may not be addressed in this manual, or for further information on a topic, do not hesitate to contact your local Bruker office. Please also review the Pre-installation Siting Review at the end of the manual.

Note that site planning is not only relevant for the installation of a new system, rather also by any changes in the equipment or devices, and by any renovations or room changes.

1.1 Units Used Within This Manual

The SI Unit Tesla (mT) is used throughout this manual whenever magnetic field strengths are discussed. Some readers may however be more familiar with the Gauss (G) Unit.

For comparison the conversion fact is: 1 mT=10 G

Likewise the unit kilowatt is used for the measure of heat energy (e.g. amount of heat generated by a device per hour). Some readers may be more familiar with these measurements in BTU/hour:

For comparison the conversion factor is: 1 BTU/hour=0.000293 kW.

(BTU = British Thermal Unit which is the required heat to raise 1 pound of H₂O by 1 degree Fahrenheit).

Wherever possible both the metric and American (North and South) measure units have been used throughout this manual. In most cases the weights and measures have been rounded upwards where necessary. The following table offers the common metric to American conversion factors used in this manual:

Measure	Metric Units	American Standard Units	Conversion Factor (rounded to nearest hundredth)	
Linear	meter (m)	feet (ft.)	1 m = 3.28 ft.	
	centimeter (cm)	inch (in.)	1 m = 39.37 in. 1 cm = 0.394 in.	
Distance	kilometer (km)	mile (mi.)	1 km = 0.62 mi.	
Area	square meter (m ²)	square foot (ft ²)	1 m ² = 10.76 ft ²	
Volume	cubic meter (m ³)	cubic foot (ft ³)	1 m ³ = 35.32 ft ³	
	liter (l)	quart (qt.)	1 l = 1.06 qt. (liquid)	
Weight	kilogram (kg)	pounds (lbs.)	1 kg. = 2.21 lbs.	
Pressure	bar	pounds/square inch (psi)	1 bar = 14.51 psi	
		atmosphere (ATM)	1 bar = 0.99 ATM (standard)	
Flow (e.g. gas flow)	cubic meter/minute (m ³ /min.)	cubic feet/minute (ft ³ /min.)	1 m ³ /min. = 35.32 ft ³ /min.	
Temperature	°C	°F	F = C × 1.8 + 32	
	°F	°C	C = (F - 32) / 1.8	
	°C	K	K = C + 273.15	
	K	°C	C = K - 273.15	
	°F	K	K = (F + 459.67) / 1.8	
	K	°F	F = K × 1.8 - 459.67	
	Magnet Field Strength	Tesla (T)	Gauss (G)	1 T = 10 ⁴ G
	Heat Energy	BTU/hour	kW	1 BTU/hour = 0.000293 kW

BTU = British Thermal Unit which is the required heat to raise 1 pound of H₂O by 1 degree Fahrenheit.

SI = International System of Units.

Table 1.1: Metric to American Conversion Factors

2 Safety

These safety notes must be read and understood by everyone who comes into contact with superconducting NMR Magnet Systems. Proper training procedures must be undertaken to educate all people concerned with such equipment about these requirements. It is essential that clear notices are placed and maintained to effectively warn people that they are entering a hazardous area. Please refer to **Bruker's General Safety Considerations for the Installation and Operation of Superconducting Magnets**, available from Bruker.

2.1 The Magnetic Field

Since the magnetic field of the NMR magnet system is three dimensional, consideration must be given to floors above and below the magnet, as well as to the surrounding space on the floor the magnet resides on. The magnetic field exerts attractive forces on equipment and objects in its vicinity. These forces, which increase drastically approaching the magnet, may become strong enough to move large equipment and to cause small objects or equipment to become projectiles.

It is important to consider personnel and equipment in the rooms above, below, and adjacent to the room where the magnet will be located:

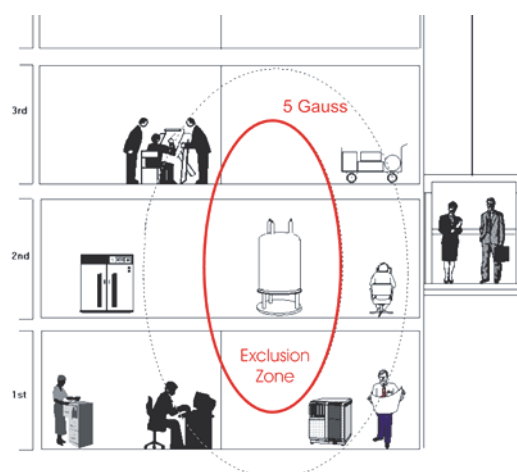

Figure 2.1: Stronger Stray Fields in Vertical Direction than in Horizontal Direction

The magnetic field may affect the operation of electronic **medical implants** such as pacemakers, if exposed to fields greater than 5 gauss. Medical implants such as aneurysm clips, surgical clips or prostheses may also be attracted. Further care must be taken around changing fields (e.g. pulsed gradient fields). Eddy currents could be generated in the implant resulting in heat generation and/or unwanted torques.

Ensure that all **loose ferromagnetic objects** are outside the 5 gauss (0.5 mT) field zone of the magnet before the magnet is ramped to field. Human experience and reaction speed are totally inadequate to cope with the extremely nonlinear forces the magnet exerts on iron objects. Therefore no ferromagnetic objects should be allowed to enter the magnet room after the magnet is energized.

2.1.1 Exclusion Zone

The **Exclusion Zone** is the area inside the magnet's 5 gauss (0.5 mT) field line, extended in all directions, including rooms above and below the magnet area.

Individuals with cardiac or other medically active implants must be prevented from entering this area. The exclusion zone must be enforced with a combination of warning signs and physical barriers.

2.1.2 Security Zone

The **Security Zone** is usually confined to the room that houses the magnet.

Ferromagnetic objects should not be allowed inside the security zone to prevent them from becoming projectiles.

2.1.3 Standards on Health and Safety in the Workplace

Guidelines on Limits of Exposure to Static Magnetic Fields are introduced by the ICNIRP (International Commission on Non-Ionizing Radiation Protection). They give separate guidance for occupational exposures and exposure of general public.

Occupational Exposures:

It is recommended that occupational exposure of the head and the trunk should not exceed a spatial peak magnetic flux density of 2 mT (20 Gauss) except for the following circumstance:

For work applications for which exposures above 2 mT (20 Gauss) are deemed necessary, exposure up to 8 mT (80 Gauss) can be permitted if the environment is controlled and appropriate work practices are implemented to control movement-included effects. Sensory effects due to the movement in the field can be avoided by complying with basic restrictions set in the ELF guidelines. When restricted to the limbs, maximum exposures of up to 8 mT (80 Gauss) are acceptable.

General Public exposures:

Based on scientific knowledge on the direct effects of static fields on humans, acute exposure of the general public should not exceed 400 mT (any part of the body). However, because of potential indirect adverse effects, ICNIRP recognizes that practical policies need to be implemented to prevent inadvertent harmful exposure of people with implanted electronic medical devices and implants containing ferromagnetic materials, and injuries due to flying ferromagnetic objects, and these considerations can lead to much lower restriction levels, such as 0.5 mT (IEC 2002). The exposure limits to be set with regard to these non biological effects are not, however, the duty of ICNIRP.

* From ICNIRP Guidelines published 2009 (<http://www.icnirp.de/documents/statgdl.pdf>)

Example:

The European Community did release a **Directive 2004/40/EC** on the minimum health and safety requirements regarding the exposure of workers to the risks arising from physical agents (electromagnetic fields).

This directive, depending on the frequency, gives the following physical quantities to specify the exposure limit values of electromagnetic fields:

Frequency Range	Magnetic Field Strength H	Magnetic Flux Density B
0...1 Hz	1.63×10^5 A/m	0.2 T or 200 mT

Magnetic field strength is a vector quantity (H), which, together with the magnetic flux density, specifies a magnetic field at any point in space. It is expressed in Ampere per metre. (A/m).

Magnetic flux density is a vector quantity (B), resulting in a force that acts on moving charges, expressed in (T). In free space and in biological materials, magnetic flux density and magnetic field strength can be interchanged using the equivalence $1 \text{ A/m} = 4\pi \cdot 10^{-7} \text{ T}$.

In Germany, regulation BGV B11 describes the maximum exposure doses in two basic tables. Table 2.1 applies to situations under the standard precautionary conditions, whereas Table 2.2 applies to systems with field strengths above 5 Tesla and can only be applied to certain subgroups of people, which meet nonstandard precautionary conditions. Details on the different precautionary conditions and subgroups of people are given in the document BGV B11 document.

Exposure	Maximum Magnetic Flux Density
Average over 8 hours	212 mT
Peak values for head and body	2T
Peak values for extremities	5T
<i>Standards on health and safety in the workplace for standard precautions and users, according to BGV B1.</i>	

Table 2.1: BGV B11 Standards for Standard Precautions and Users

Exposure	Maximum Magnetic Flux Density
Average over 8 hours	4T
Peak values for head and body	Table 2.1 is valid
Peak values for extremities	10T
<i>Health and safety standard in the workplace applicable under special conditions to selected subgroups of people, according to BGV B11.</i>	

Table 2.2: BGV B11 Standards Under Special Conditions for Selected Subgroups

The next table shows the maximum retention periods within different stray field regions below 5 Tesla for standard precautionary situations. The corresponding spatial regions within and around the super-conducting magnet can be worked out from the stray-field plots of the magnet being used.

Magnetic Flux	Retention Period	Parts of the Body
5T	< 20 Minutes	Extremities
4T	< 25 Minutes	Extremities
3T	< 34 Minutes	Extremities
2T	< 52 Minutes	Head/Body
1T	< 1 Hour 42 Minutes	Head/Body
0.5T	< 3 Hours 23 Minutes	Head/Body
0.3T	< 5 Hours 39 Minutes	Head/Body
<i>We do not take any responsibility for the numbers given in this table!</i>		

Table 2.3: Example of Maximum Retention Periods

If higher field strength is accessible inside the magnet by a user's extremities, a corresponding table for non-standard situations can be worked out from the table above. However, the analysis must be carried out in a more detailed and differentiated manner and a greater number of more important conditions must be strictly fulfilled.

2.2 Ventilation

Superconducting magnets use liquid nitrogen and liquid helium as cooling agents. During normal operation of the magnet system it can be expected that a boil-off of liquid cryogenics will occur:

- A normal boil-off of liquids contained in the magnet will occur based on the established boil-off specifications.
- A boil-off of cryogenics will occur during regular refills with liquid nitrogen and liquid helium.

A very large increase in volume accompanies vaporization of the cryogenic liquids into gas. The cryogenic gas to liquid volume ratios are approximately 740:1 for helium; 680:1 for nitrogen. Due to this large increase in volume the vapor may displace the air in an enclosed room. If someone is in the room, this may lead to **asphyxiation**. To prevent this and other dangers, the following minimum general safety rules concerning ventilation apply:

- Cryogenic liquids, even when kept in insulated storage dewars, remain at a constant temperature by their respective boiling points and will gradually evaporate. These **dewars** must always be allowed to vent or dangerous pressure buildup will occur.
- Cryogenic liquids must be handled and stored in well ventilated areas.
- **Exit doors must open to the outside**, to allow safe exit in the event the room becomes pressurized by helium gas during a magnet quench.
- Room layout, ceiling clearance and magnet height must be such that an easy **transfer of liquid** nitrogen and helium is possible. This will considerably reduce the risk of accidents.

See also

 [Oxygen Level Sensors \[▶13\]](#)

2.2.1 Regular Ventilation

Regular HVAC systems should be able to handle 3 - 5 room air exchanges per hour, and provide temperature stability of +/- 0.5°C. Please refer to *HVAC (Heating Ventilation Air Conditioning) [▶54]* for more details.

2.2.2 Emergency Ventilation

Depending on the actual size of the magnet room, a large amount of He and/or N₂ gas could displace the air in the room. This is possible during the initial cooling of the magnet, during follow-up cryogen fills, or in case of a quench. Therefore, an emergency exhaust system may be required to avoid asphyxiation. Please refer to the section *Emergency Ventilation During Installation and Quenches* [[56](#)], for more details.

Pits



Pits:

As discussed in *HVAC (Heating Ventilation Air Conditioning)* [[54](#)], continuous air flow (exhaust) is required within the confines of a magnet pit. A low exhaust down in the pit is recommended. Additional emergency ventilation may also be necessary, particularly if the pit is >1.09m (3.5') deep (average mouth-height of a person). Since nitrogen gas cannot be detected by the human senses, an oxygen sensor mounted in the pit will trigger an increased rate of exhaust.

2.2.3 Oxygen Level Sensors

Oxygen (O₂) monitors, or level sensors, are required in the magnet room to detect low levels of O₂ due to cryogenic gases. At a minimum the following sensors must be provided:

- One oxygen level sensor must be above the magnet, to detect low oxygen levels caused by high helium gas levels.
- One oxygen level sensor approx. 30 cm off the floor of the magnet room.
- One additional oxygen level sensor approx. 30 cm off the bottom of the pit, in case the magnet is located inside a pit.

These monitors and sensors generally must be located outside the 0.5 mT (5 G) line. Check with original equipment manufacturer for information on the effects of magnet fields on these devices.

Please refer to *Emergency Ventilation During Installation and Quenches* [[56](#)] for more information on ventilation and exhaust solutions.

2.3 Safe Handling of Cryogenic Substances

Superconducting magnets use liquid helium and nitrogen as cooling agents, keeping the magnet core at a very low temperature. The safe handling of cryogenic liquids requires some knowledge of the physical properties of these liquids, common sense, and sufficient understanding to predict the reactions of such liquids under certain physical conditions.

Cryogenic liquids, even when kept in insulated storage vessels (dewars), remain at a constant temperature by their respective boiling temperature. As a result, a fraction of the liquid constantly evaporates into the gas phase, leading to a pressure build-up inside the storage dewar. A very important characteristic of cryogenics is their enormous increase in volume during the conversion from liquid to gaseous phase. This conversion follows a raise in gas temperature starting at the boiling temperatures of the cryogenic liquids and going up towards room temperature.

The gases are nontoxic and completely harmless as long as adequate ventilation is provided to avoid suffocation. During normal operation only **3-5 m³/day** of nitrogen are evaporated, but during a quench, an extremely large quantity of helium gas is produced within a short time.

Cryogenic liquids must be handled and stored in **well ventilated areas**. Containers for cryogenic liquids must be constructed with non-magnetic materials and should be specifically designed for use with particular cryogens. Be sure to read and follow any specific instructions provided by the container manufacturer concerning their individual products.

2.3.1 Refill of Liquid Nitrogen

Keep contact with air at a minimum. When liquid nitrogen is exposed to air, it can condense and become as hazardous as liquid oxygen. The **pressure relief valve** for the nitrogen vessel should be mounted at all times, even when the vessel is being refilled. Special attention is required for the **transportation of cryogens by elevator**, no one should be allowed to be in the elevator with a cryogen dewar.

When the vessel is being refilled, liquid nitrogen should not be allowed to spill onto the room temperature bore closure flanges. Place gum rubber or Teflon tubes on the nitrogen neck tubes during refill. The transfer should be stopped immediately when the vessel is full. Failure to observe this can lead to the freezing of the O-rings and a subsequent vacuum loss of the magnet cryostat.

The liquid cryogen transport dewars used to refill the magnet must be of the low pressure type. **Never use high pressure gas-packs.** The dewar must have a fixture for pressurizing and transferring via a stainless steel or corrugated plastic tube (10 mm inner diameter). Where possible the dewar should be self pressuring. The typical transport dewar pressure for transferring liquid nitrogen is 0.10 - 0.20 bar (1-3 psi), the maximum 0.35 bar (5 psi).

2.3.2 Refill of Liquid Helium

Liquid helium is the coldest of all cryogenic liquids, therefore it will condense and solidify any other gas (air) coming in contact with it. The consequent danger is that pipes and vents may become blocked with frozen gas. Vacuum insulated pipes should be used for transferring liquid helium. The helium vessel should be checked weekly for helium level and overpressure.

Liquid helium must be kept in specially designed storage or transport dewars. A one-way valve is supplied to avoid air or moisture from entering the helium vessel. This is to prevent ice from building and plugging the neck tubes. The 0.2 bar valve must be mounted at all times even during a helium transfer.

A helium gas cylinder is typically used to pressurize the liquid helium transport dewars during the helium refills. The helium gas cylinder should never be brought close to the magnet and should always be kept well outside the 5 Gauss line. The gas cylinder should be secured to a wall or structural column well outside the 5 Gauss line to prevent a dangerous accident.

 **CAUTION****Danger of cold burns or freezing during the transfer of liquid helium.**

During the transfer of liquid helium it is possible that cold burns or freezing may occur.

- 
- ▶ The transfer of liquid helium can be done easily and safely, provided the helium transfer line is in good condition, is handled correctly, and the transfer pressure does not exceed 3.5 psi (0.24 bar).
 - 1. Never connect a warm helium transfer line to the magnet as the warm helium gas could disturb the magnet temperature.
 - 2. Always allow the helium transfer line to cool down to helium temperature before connecting it to the short end inserted into the helium fill port.
 - 3. Adequate protection and clothing is required at all times when handling, transferring, or operating near cryogenic fluids.

2.4 Earthquake Safety

In regions where there is a potential risk of earthquakes, additional precautions should be taken to reduce the chance of personal or property damage through movement or tipping of the magnet.

Many countries or regions have documented regulations, including building codes, regarding earthquakes. Before installing a magnet system, it is highly advisable that you check with local authorities on whether your area is prone to earthquakes and if there are any regulations in effect.

If your area is regarded as an earthquake area there are several shock absorbing methods or riggings available to reduce the likelihood of damage during an earthquake. Please contact Bruker for more information on earthquake securing equipment.

2.5 Country-Specific Safety Regulations

In addition to the above safety precautions, any country-specific safety regulations for operating NMR systems must be fulfilled. These may include, for example, regulations on:

- Facilities of a controlled access area around the magnet
- Working conditions at computer stations
- Use of anesthesia gases
- Handling of laboratory and transgenic animals

2.6 Emergency Planning

Due to the strong magnetic fields and presence of cryogenics when using NMR systems, it is important to define and communicate what to do in case of problems or an emergency. An **Emergency Plan** can be defined as a documented set of instructions on what to do if something goes wrong. Emergency Plans are often defined as part of the Standard Operating Procedures (SOP), or as a stand-alone document. In any case every NMR laboratory should have an Emergency Plan in effect in case of problems or emergencies.

As every organization has its own policies and procedures, as well as varying laboratory layouts, an Emergency Plan should be individually defined for each laboratory as appropriate. Upon request Bruker can provide useful information on emergency planning.

2.6.1 Fire Department Notification

It is recommended that the magnet operator introduce the fire department and/or local authorities to the magnet site. It is important that these organizations be informed of the potential risks of the magnet system, i.e. that much of the magnetic rescue equipment (oxygen-cylinders, fire extinguishers, axe's etc.) can be hazardous close to the magnet system. On the other side, their expertise and experience can be invaluable in creating an Emergency plan.

- Within a NMR laboratory CO₂ magnetic fire extinguishers must NOT be used.
- Breathing equipment which uses oxygen tanks made out of magnetic material can be life threatening when used close to a magnet system which still has a magnetic field present.
- Helium gas escaping from the system must not be mistaken for smoke. Instruct the fire department and technical service not to „extinguish“ the magnet system with water. The outlet valves could freeze over and generate excess pressure within the system.
- NMR laboratory windows which are accessible during an emergency must be clearly marked with warning signs, visible from the outside.

3 Equipment

This section describes the types and functions of the various sub-systems that are delivered as part of our AVANCE UltraStabilized NMR systems. These include the following:

- [Superconducting Magnet Components \[▶17\]](#).
- [Console and Other System Components \[▶18\]](#).
- [CryoProbe System \(Optional\) \[▶19\]](#).
- [Other Optional Components \[▶20\]](#).

3.1 Superconducting Magnet Components

This section describes the basic operation of an NMR superconducting magnet.

Purpose:	The superconducting magnet is a complex system producing a very strong, homogeneous, and stable magnetic field, which is required for NMR.
Magnet temperature:	The magnet uses both liquid nitrogen and liquid helium. The magnet coil is immersed in liquid helium inside a dedicated helium vessel. Liquid nitrogen fills a different vessel and reduces the helium evaporation rate.
UltraStabilized Magnets:	The magnet coil is immersed in a liquid helium bath at a sub-cooled temperature (~2 K). An additional liquid helium bath operating at a standard temperature of 4.2 K is located above the sub-cooled helium section.
Magnet current:	After the initial charging with electrical current, the magnet runs in persistent mode. The current runs in a closed loop inside the system and the magnet itself is no longer connected to a continuous power supply.
Pump-line	The sub-cooled systems are equipped with a special pump line in order to reduce the liquid helium temperature from 4.2 K to ~2 K. The pump line connects one port of the magnet to a set of pumps. Pumping is done on a Joule-Thompson Cooling Unit located inside the cryostat in order to reduce the temperature of the liquid helium (by using this method the large volumes of liquid and gaseous helium in both temperature zones can be kept slightly above atmospheric pressure).
Maintenance:	Magnet maintenance consists of refilling the system with cryogenic fluids at defined time intervals.

See also

 [Compressed Gas \[▶49\]](#)

3.2 Console and Other System Components

The next table lists the various parts of the console, monitoring & control units. Please also refer to the floor plan diagrams beginning in the chapter [Floor Plan \[▶59\]](#). These scaled diagrams provide an idea of where the various pieces of NMR equipment should be placed.



Figure 3.1: Spectrometer and Magnet Control

1.	The AVANCE console main cabinet, where the actual NMR data acquisition is performed.
2.	The probe , which is designed to hold the sample, transmit radio frequency signals which excite the sample and receive the emitted response. The probe is inserted into the bottom of the magnet and sits inside the room temperature shims. Coaxial cables carry the excitation signals from the console amplifiers to the probe and the NMR signal back from the sample to the receiver.
3.	The HPPR/2 amplifies, filters and routes the NMR response signals from the probe to the RX22 receiver. It switches the RF transmitter output to the probe.
4.	The Bruker Magnet Pump Control (BMPC II) , which monitors the magnet status and cryogenic parameters, interfaces between the magnet, pump system, and user. The BMPC II includes the pumps that drive the Joule-Thompson cooling unit in order to maintain the temperature of ~2K.
5.	The Uninterruptable Power Supply (UPS) feeds the BMPC II and provides continuous power in case of power failure. The UPS also acts as a power conditioner. It is recommended to have the UPS on emergency power.
6.	The workstation acts as the operational computer for the user processing NMR data and sending/receiving data to/from the acquisition computer in the main console.
7.	The BCU-II Unit delivers very cold gas, either nitrogen or dry air, through a flexible isolated non-magnetic transfer line. It is possible to control the sample temperature down to -60°C inside the probe for solid or liquid NMR applications.
8.	The BCU-I Unit cools VT gas to allow proper sample temperature regulation. The unit reduces the temperature of the air input (supplied by the variable-temperature unit) and provides cooling of the NMR sample within the magnet to at least -5 °C for a room temperature of 25 °C.
9.	Air compressor (not pictured). The air compressor should have a maximum duty cycle of 50%. When the area where the compressor is located is very humid, air conditioning should be used. If floor vibrations are a problem, insulation should be used.

3.3 CryoProbe System (Optional)

The Bruker CryoProbe™ Accessory for the AVANCE NMR spectrometers offers dramatic increases in signal to noise ratio, stability, and ease of use. For site planning details for the CryoProbe accessory, refer to *CryoProbe and Other Accessories* [▶73].

The CryoProbe system consists of the following components:

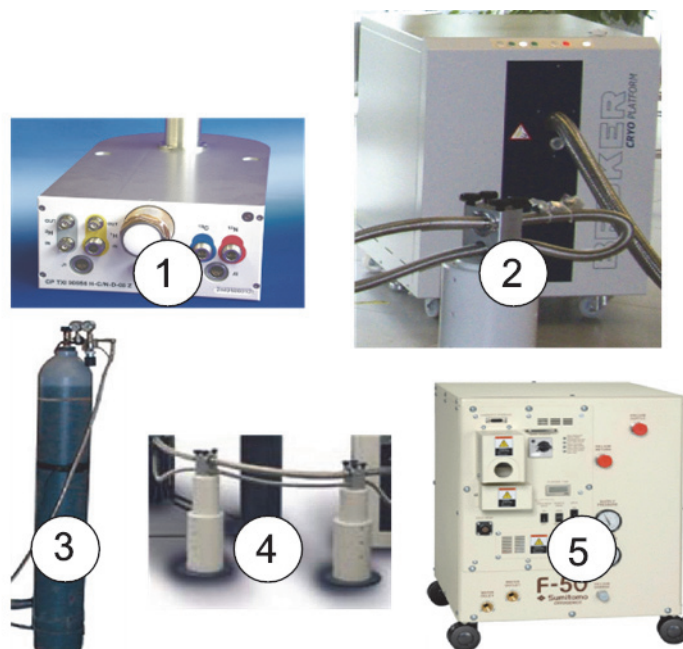

Figure 3.2: CryoProbe System

1.	The CryoProbe represents the NMR probe inside the magnet bore, and is cooled by cryogenic helium gas. The CryoProbe maximizes efficiency and reduces thermal noise, thus enhancing the signal-to-noise ratio.
2.	The CryoCooling unit contains a cryocooler, a cryocontroller, a vacuum system, and He transfer lines. The unit cools compressed helium gas by expansion and provides and maintains the vacuum insulation. The unit also supervises all CryoProbe operations.
3.	The research grade Helium gas cylinder provides research grade helium gas (99.9999%) at high pressure (min. 200 bar) for flushing the probe prior to a cool-down cycle. The cylinder includes a regulator, an outlet valve, and a charging hose.
4.	A transfer line supports provide support for the probe and isolates the probe against vibrations.
5.	The He compressor provides compressed helium gas to the CryoCooling unit. The compressor connects to the CryoCooling unit by means of helium gas pressure lines. The indoor water-cooled helium compressor is shown to the right. Other models, including indoor air-cooled and outdoor air-cooled, are available.

3.4 Other Optional Components

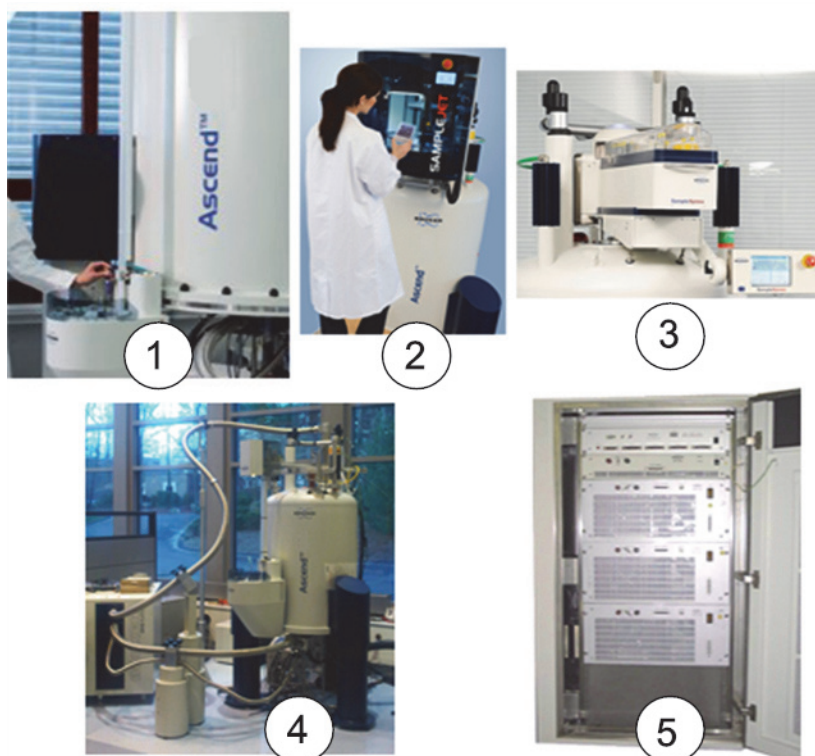

Figure 3.3: Other Options for AVANCE Systems

1.	SampleCase is a 24 sample, random-access, automation system that fits almost all shielded Bruker standard bore magnets.
2.	SampleJet is a robot which has been consciously designed to meet growing demand for simplicity, versatility and higher throughput in NMR sample tube automation.
3.	SampleXpress allows automatic measurement of NMR samples with Bruker NMR spectrometers. SampleXpress is controlled by TopSpin or IconNMR, and is equipped with integrated barcode reader registration, which is under control of SampleTrack.
4.	The Bruker Smart Nitrogen Liquefier (BSNL) is an accessory available for systems with the CryoProbe option, that uses the extra cooling capacity of the latest generation CryoPlatform to re-condense the evaporating nitrogen gas from the magnet dewar.
5.	The imaging accessory cabinet houses the gradient amplifiers for micro-imaging applications.

4 Magnet Access and Rigging

The magnet is very heavy and fragile, thus requires special consideration during delivery and movement to its final installation point. The other components of the spectrometer system (console, options, etc.) can typically be removed from the trucks with forklifts and are positioned in the NMR lab with a pallet jack. Specifications for these components are also included in this chapter for planning purposes.

4.1 Considerations for Off-loading on Site

When planning for offloading the magnet and console during delivery, the following factors must be considered:

Delivery Area

There must be sufficient space in the driveway or parking area for the overhead crane (or forklift) and for the delivery truck. There must also be sufficient leveled area for uncrating the magnet and other crates.

Transport Weight

The transport weight and size of the magnet system, console and their respective crates will affect the choice of equipment required for offloading and movement of the magnet.

Loading Dock

The **size and overhead clearance** of the loading dock will influence the choice of forklift, crane, or other rigging equipment required to off load the magnet and system crates.

The **elevation** of the loading dock relative to the NMR room will determine if a crane is required, or if an elevator is needed for the transportation of the magnet from the loading dock to the NMR room.

The **load bearing capacity** of the loading dock must be sufficient for the system. Refer to the transport weights of the magnet system, console, and accessories listed in the chapter.

If height/width restrictions require the magnet to be removed from the pallet (e.g. to pass through a doorway), rigging equipment will be needed both on the loading dock and inside the lab.

Equipment Requirements

All rigging equipment required to off-load the magnet system must be selected to handle the size and transport weights of the system.

Generally a **pallet** is integrated in the magnet crate. The top and sides of the crate are removed or lifted off the magnet, leaving the pallet under the magnet for transportation into the lab.

Crane: For larger magnet systems, a crane meeting the load requirements for the specific magnet may be required to lift the magnet off the truck, place it on a flat surface for uncrating, and for lifting the magnet again for placement on air skates or a pallet.

Forklift: It may be feasible to use a forklift to pick the magnet from the truck and lower it to a flat surface for uncrating.

Pallet Jack: If a loading dock is available, it may be possible to roll the magnet off the truck using a pallet jack.

See also

- 📄 [Magnet Transport Weights \[▶23\]](#)
- 📄 [Magnet Transport Dimensions \[▶23\]](#)

4.2 Considerations for Transport to the NMR Room

Before delivery the customer must ensure that the system and magnet can be transported to the site. The section on *Transport Dimensions and Weights* [[▶23](#)] in this chapter provides the sizes and weights of the crates in which the system are shipped. The following must be considered:

- The access clearance (height and width) and **floor loading capacity** must be checked along the entire route that the magnet will take from the access point into the building to the NMR room. Please refer to the Transport Dimensions and Transport Weights tables.
- Transport will also be affected by any floor irregularities and the presence of door jams and steps. Use masonite **leveling sheets** to traverse floor irregularities such as cracks and door seals.
- **Elevator** capacity and dimensions must also be considered if the magnet must make an elevation change within the building.
- The **turning radius** can also be a factor if, for example, corners must be navigated. It is important to make sure the rigging equipment for magnet assembly (e.g. a long I-beam for the gantry) can be brought into the lab.
- The console and magnet must be moved in an **upright position**.

Refer to the section *Rigging Equipment* [[▶24](#)] for more information.

See also

- 📄 [Magnet Transport Dimensions \[▶23\]](#)
- 📄 [Magnet Transport Weights \[▶23\]](#)

4.3 Transport Dimensions and Weights

4.3.1 Magnet Transport Dimensions

System	Crate Size (m)			Minimum Door Dimensions (m)		
	L	W	H	Width Un-crated	Height Un-crated*	Height if Crane is Used**
Ascend 800, Ascend 850	2.0	1.8	2.7	1.4	2.4	3.9
850 WB US ² , 900 US ² , 900 WB US ² , 950 US ²	2.4	2.2	3.0	1.8	3.0	4.6
WB = Wide Bore (89 mm), US ² = UltraShield-UltraStabilized * Including air skates (cushions) required to move the magnet. ** These numbers are approximate; the true number will depend on the distance between the boom of the crane and the bottom of the magnet.						

Table 4.1: Door Dimensions for Magnet Access

4.3.2 Magnet Transport Weights

The transport weights for each magnet are listed below. For the weights of the rest of NMR equipment, please refer to the dimensions and weights table in the *Floor Plan* [[59](#)] chapter.

Magnet Type	Approx. Transportation weights - crated (kg/lbs.)
Ascend 800	4,100 / 9,020
Ascend 850	4,100 / 9,020
850 WB US ²	8,200 / 18,100
900 US ²	8,200 / 18,100
900 WB US ²	8,200 / 18,100
950 US ²	8,200 / 18,100

Table 4.2: Magnet Transport Weights

4.3.3 Spectrometer and Accessories Weights

Unit	Weight (kg)
AVANCE TwoBay	400*
Imaging Cabinet	150
UPS + extra battery (optional - highly recommended when with CryoProbe system)	260 + 165
BMPC II	250
SampleXpress	48
SampleXpress Lite	22
SampleJet	100
SampleCase	30
BCU-I, BCU-II	50, 74
CryoProbe (shipped in a CryoCase on a pallet)	60
CryoCooling Unit	400
CryoProbe System He Compressor Water-cooled	120
CryoProbe System He Compressor Air-cooled	140
Weights include pallets and packing material as required.	
* Weights are for a standard AVANCE™ configuration, actual weights may increase depending on options selected.	

Table 4.3: Transport Weights of NMR Cabinets and Accessories

4.4 Rigging Equipment

All rigging equipment must be selected to handle the *size* [▶23] and *transport weights* [▶23] of the magnet system. For Ultra High Field magnet systems, a crane or a boom-truck is required to remove the magnet from the truck and place it on the dock or slab in front of the access doors to the building. Air skates should be used during transport over floors and through passage ways whenever possible. For lifting during installation, hydraulic lifts are preferred.

Rigging equipment is not included with the NMR system order. The following rigging equipment will be needed for a typical delivery and installation of an NMR magnet system:

- **Crane:** A crane able to handle magnet load is required to lift the magnet off the truck, place it on a flat surface for un-crating, and lift it again and place it on air-skates in front of the access doors, or to place the magnet inside the building (e.g. roof hatch).
- **Leveling Sheets:** Masonite (or other suitable material) sheets may be temporarily required to level the transport route from the access doors to the NMR room, in case of small imperfections.
- **Air-Skates:** A set of four air-skates is required to transport the magnet from the access doors. The air-skates require an air-compressor capable of supplying up to ca. **1.72 bar (25 psi) at ca. 2 cu. meter/minute**.
- **Hydraulic Lifting System (Gantry):** Lifting the magnet inside the NMR room during assembly phase is typically done with a hydraulic gantry capable of handling the magnet load within the given ceiling height (please refer to [Ceiling Height Requirements](#) [▶27]).

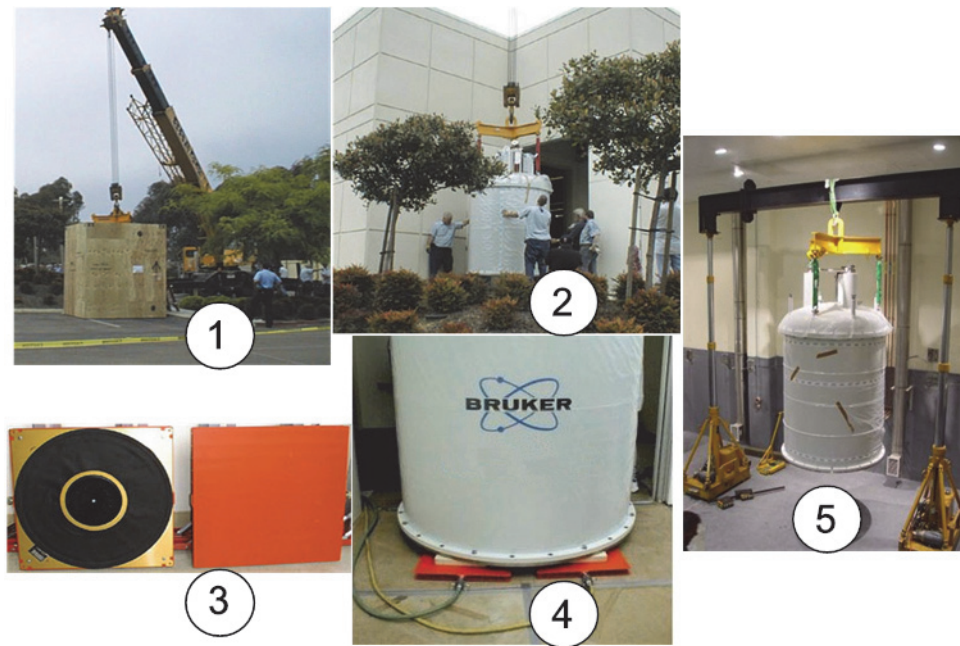

Figure 4.1: Unloading the Magnet Crate and Placing on Air Skates

1.	Unloading the magnet crate and positioning for uncrating.
2.	Lifting the magnet and placing it on air skates in front of the access doors.
3.	Air skates.
4.	Magnet positioned on air skates.
5.	Hydraulic gantry in the magnet room.

See also

📄 [Ceiling Height Requirements \[▶27\]](#)

5 Ceiling Height Requirements

The assembly of the magnet system, the magnet energization, and refills with liquid helium require minimum height clearances.

- The ceiling height requirements for the magnet installation and cryogen refills do not need to be met over the entire NMR room. Figure 5.2 illustrates that the height requirements need only be met immediately above the magnet, over an area to allow for assembly of the lifting system (if applicable), and over an area to allow for insertion of the helium transfer line.
- If a soffit is to be used, it is important to consider the area of raised ceiling needed to set-up the lifting system being used to lift the magnet during the assembly phase of the installation. If a transverse I-beam is used in conjunction with the lifting system, this must fit within the confines of the soffit.
- In lieu of a lifting system, a fixed lifting hook capable of supporting the magnet at a sufficient height can be used to assemble the magnet. However, this option is usually not ideal. See notes below.



WARNING

Fixed Hook

Danger to personnel and equipment due to falling lifting system when using a fixed hook.

- ▶ Removing the heavy hoist directly over the magnet can be very difficult and dangerous for both personnel and the magnet.
 1. It is important to consider how the hoist system and harness will be removed from a fixed lifting hook after the magnet is installed.
 2. Ensure that the hook is certified to hold the weight of the equipment before use.





Figure 5.1: Hydraulic Gantry for Lifting the Magnet Inside the Magnet Room

See also

[Minimum Ceiling Height \[▶30\]](#)

5.1 Helium Transfer Line

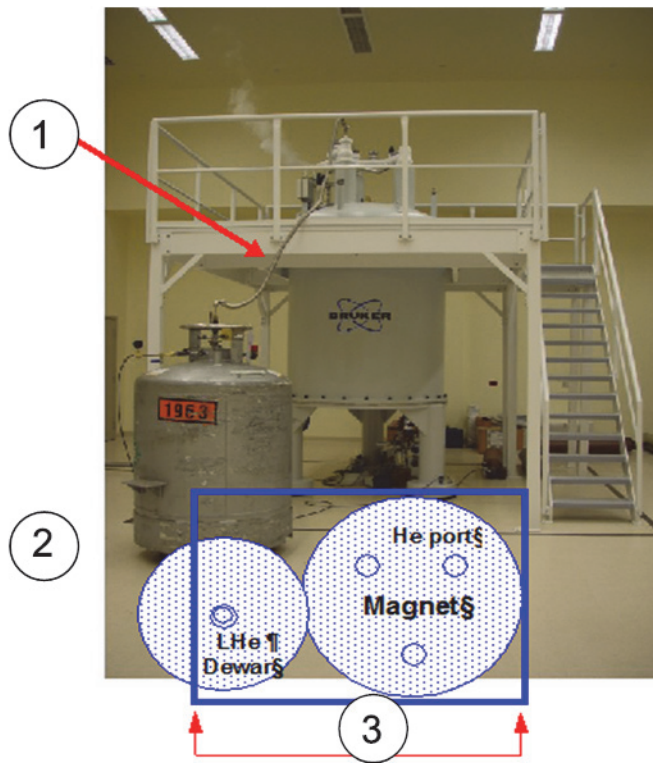

Figure 5.2: Helium Transfer Line Insertion

1.	Transfer line length = 3.6 meters (11' 10") for the flexible section.
2.	When using ceiling boxes (soffits), sufficient space must be left for the required transfer line length. The magnet may need to be off-center within the soffit.
3.	Respective ceiling height requirements must be met over this area.

5.2 Minimum Ceiling Height

Magnet Type	Minimum Ceiling Height		Minimum Hook Height (m)	Total Lifting Weight (kg)*
	For Magnet (m)	For He Transport Dewar (m)		
Ascend 800	3.60	3.60	3.10	3300
Ascend 850	3.60	3.60	3.10	3300
850 WB US ²	5.30	3.60	4.75	6700
900 US ²	5.30	3.60	4.75	6700
900 WB US ²	5.30	3.60	4.75	6700
950 US ²	5.30	3.60	4.75	6700
WB = Wide Bore (89 mm); US ² = UltraShield-UltraStabilized				
* Weight of uncrated magnet, empty, with stand.				

Table 5.1: Minimum Ceiling Height Requirements and Lifting Weights Inside the Magnet Room

6 Magnetic Stray Fields

Magnetic stray fields are three dimensional, and extend further in the vertical direction than in the horizontal direction. A number of studies have been carried out on the long term **effects of magnetic fields on personnel**. As a general rule the working place (e.g. workstation, sample preparation area etc.) must be placed outside the **0.5 mT (5 G)** line. For further information on acceptable magnetic field limits contact your countries health authorities or your area Bruker office.

We strongly recommend using all the mounting devices supplied to change gradient coils or probes. Furthermore, samples must be exchanged by using the sample supports without entering the extremities inside the magnet's bore. These preventive measures minimize doses of magnetic flux and must be applied as a general rule of thumb.

The accompanying tables in this chapter display the horizontal stray fields in the radial, direction, as well as, the vertical stray field in the axial direction.

Please note all measurements in the following tables are in meters!

6.1 Horizontal Stray Fields

Magnet Type	50 G	10 G	5 G	2 G	1 G	0.5 G
Ascend 800	1.0	1.35	1.5	2.0	2.5	3.3
Ascend 850	1.0	1.35	1.6	2.0	2.5	3.3
850 WB US ²	2.0	2.7	3.3	4.6	6.0	7.7
900 US ²	2.0	2.7	3.3	4.6	6.0	7.7
900 WB US ²	2.0	2.7	3.3	4.6	6.0	7.7
950 US ²	2.0	2.7	3.3	4.6	6.0	7.7
WB= Wide Bore (89 mm); US ² = UltraShield-UltraStabilized						

Table 6.1: Horizontal Stray Fields (distances are measured in radial directions from magnet center)

6.2 Vertical Stray Fields

Magnet Type	Distance from Floor to Magnet Center	50 G	10 G	5 G	2 G	1 G	0.5 G
Ascend 800	1.2	1.5	2.2	2.5	3.2	3.9	4.8
Ascend 850	1.2	1.5	2.2	2.7	3.2	3.9	4.8
850 WB US ²	1.6	2.6	3.9	4.6	6.0	7.3	9.0
900 US ²	1.6	2.6	3.9	4.6	6.0	7.3	9.0
900 WB US ²	1.6	2.6	3.9	4.6	6.0	7.3	9.0
950 US ²	1.6	2.6	3.9	4.6	6.0	7.3	9.0

WB= Wide Bore (89 mm); US²= UltraShield-UltraStabilized

Table 6.2: Vertical Stray Fields (distances are measured in axial directions from magnet center)

6.3 Stray Field Plots

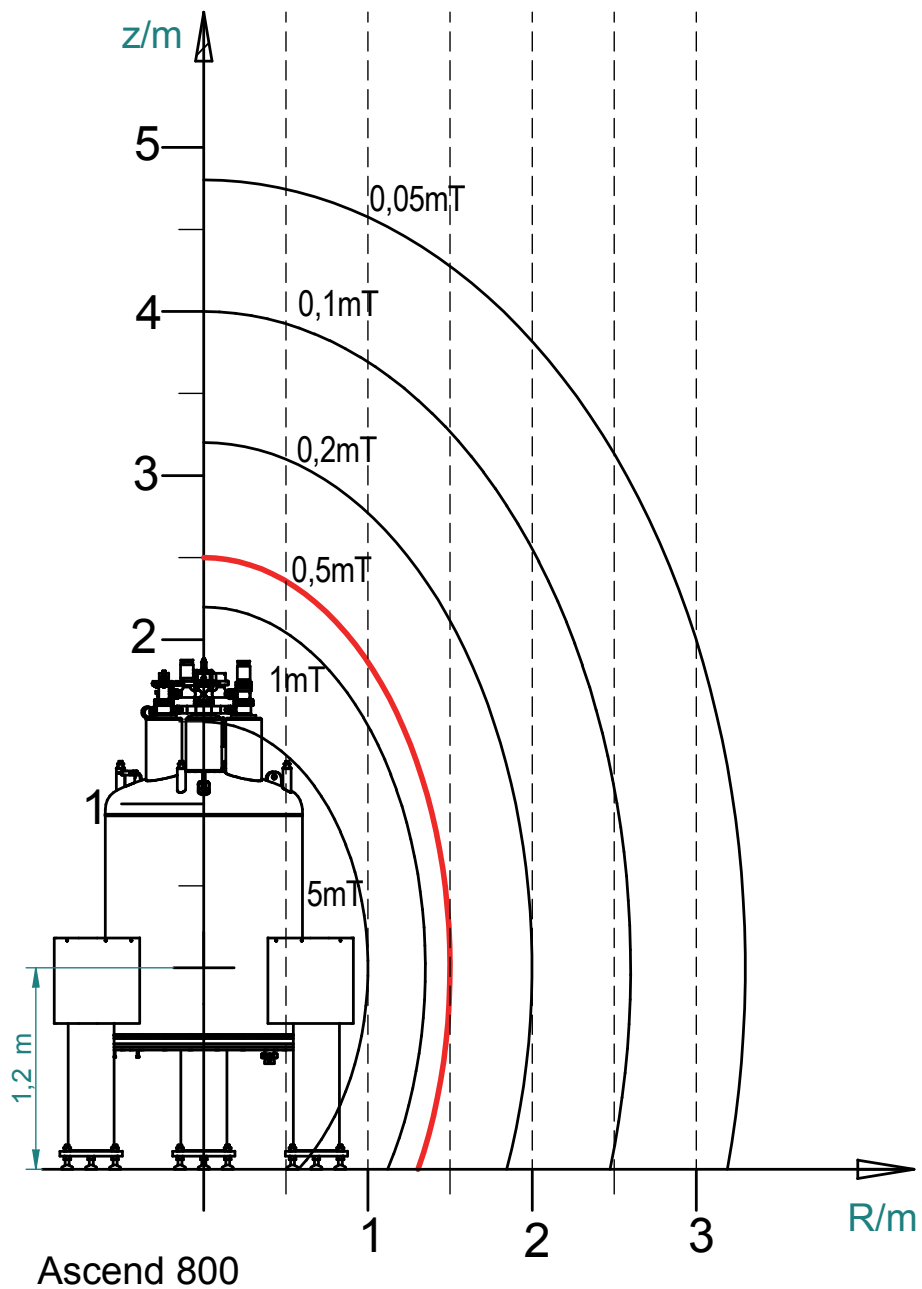

Figure 6.1: Magnetic Stray Field Plot Ascend 800

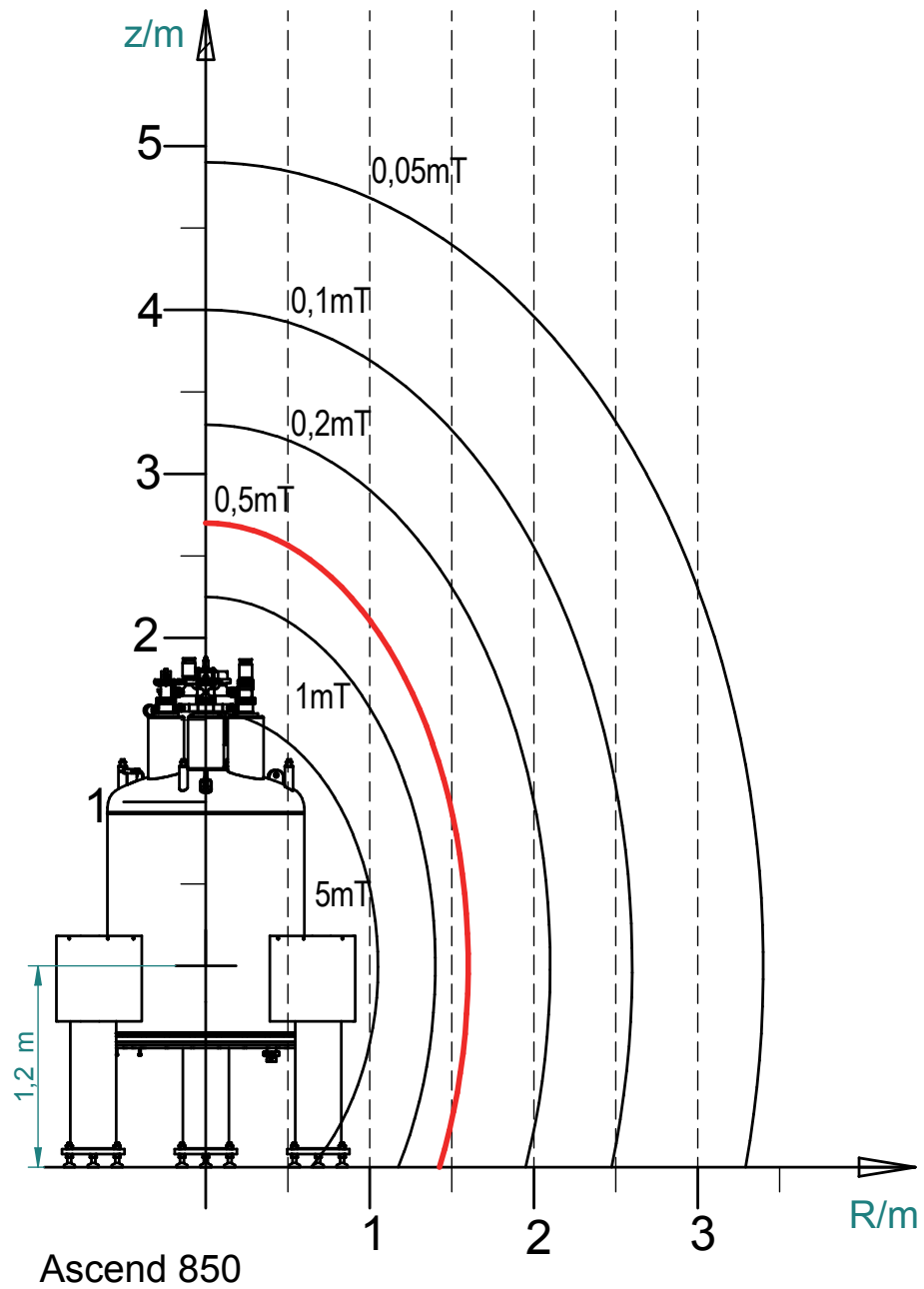

Figure 6.2: Magnetic Stray Field Plot Ascend 850

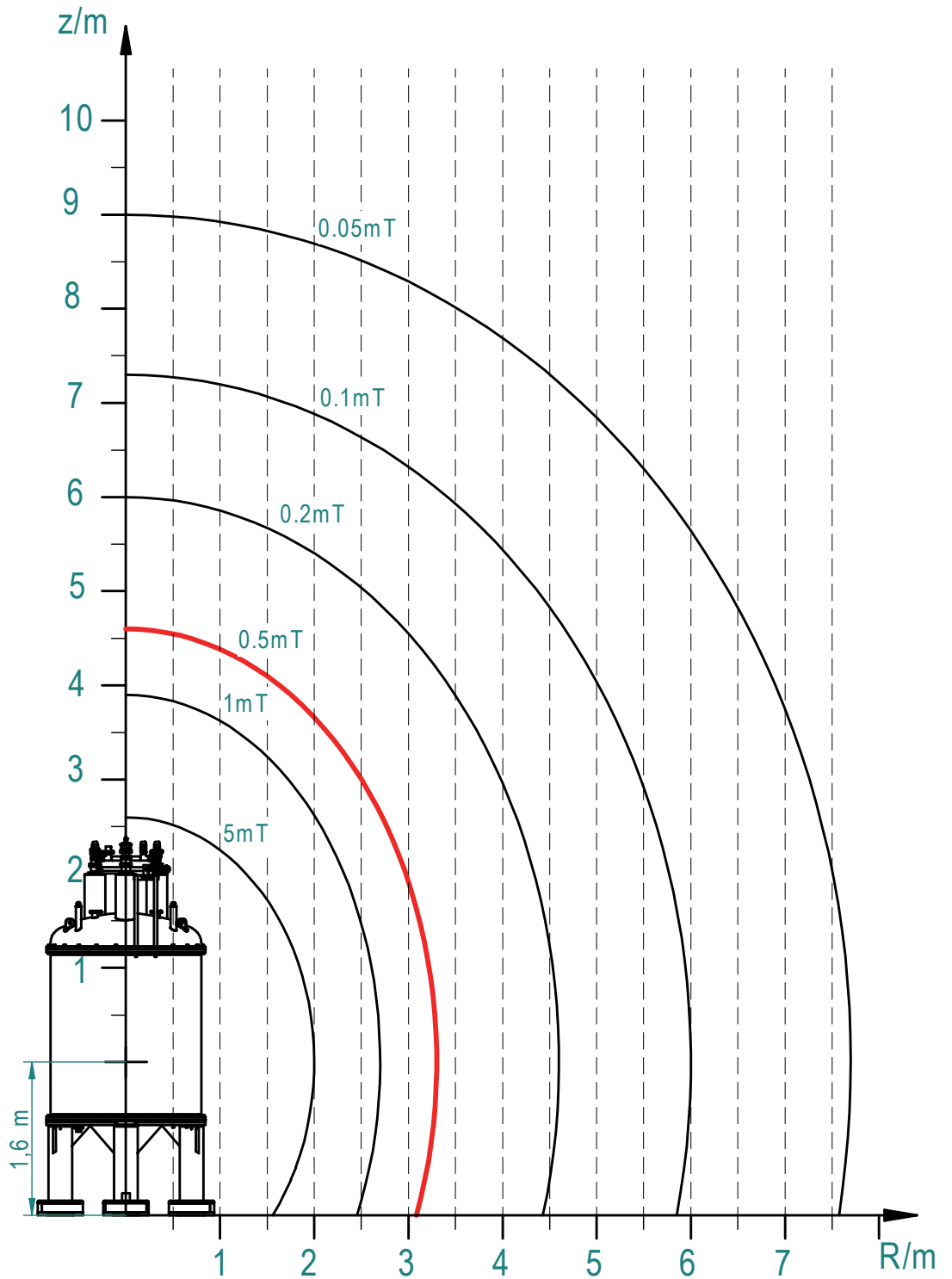

Figure 6.3: Magnetic Stray Field Plot 850 WB US2

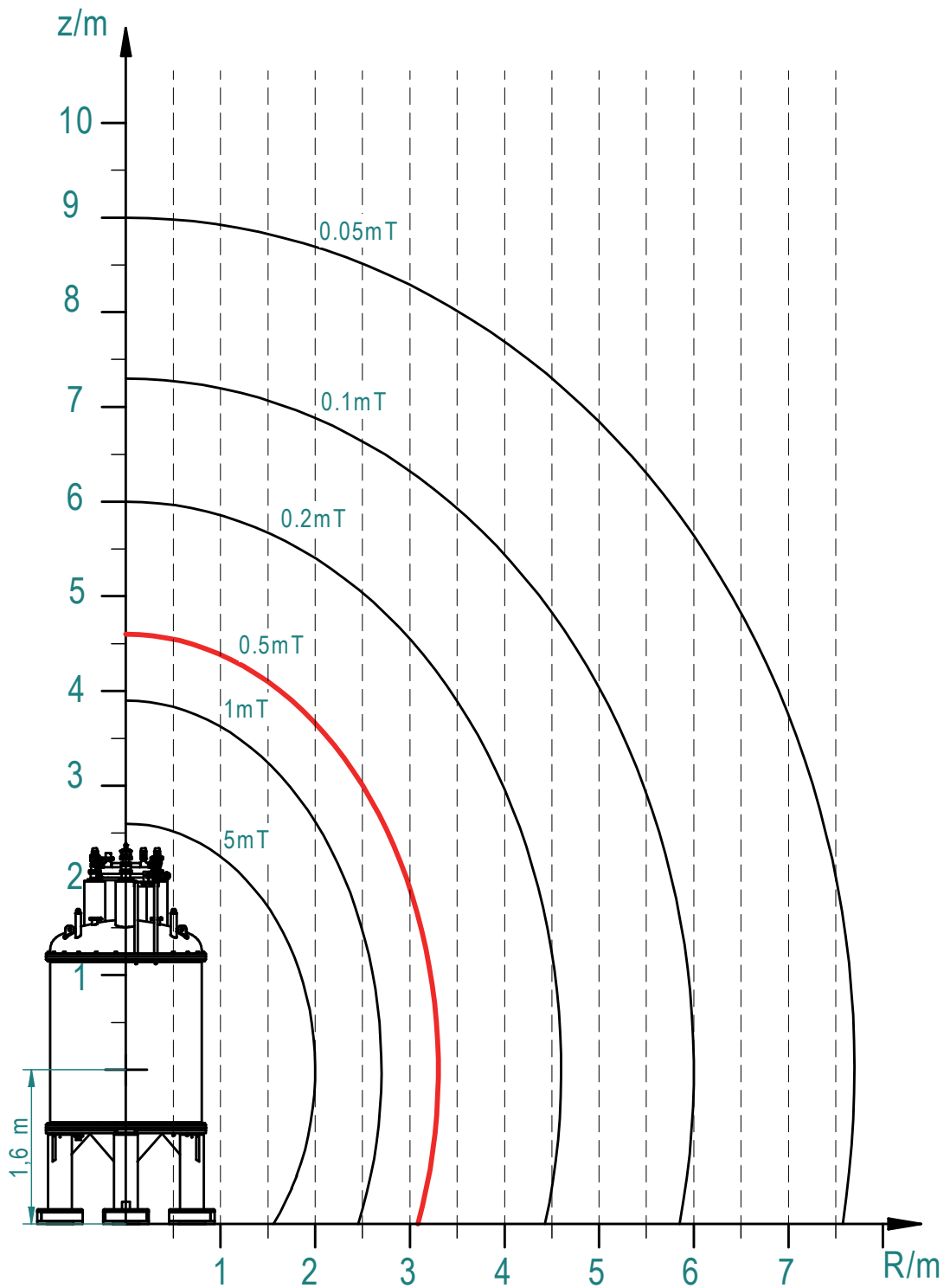

Figure 6.4: Magnetic Stray Field Plot 900 US2

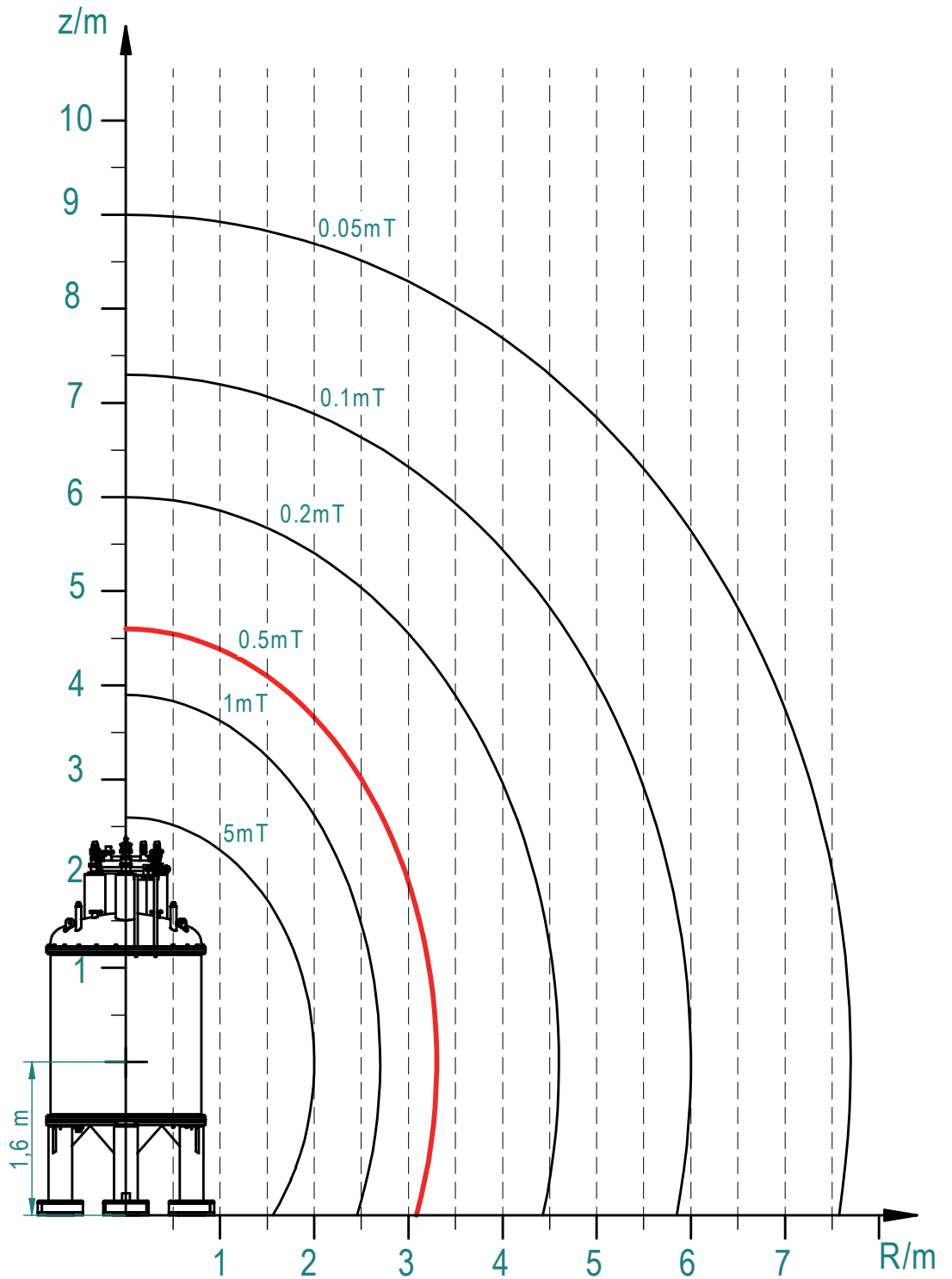

Figure 6.5: Magnetic Stray Field Plot 900 WB US2

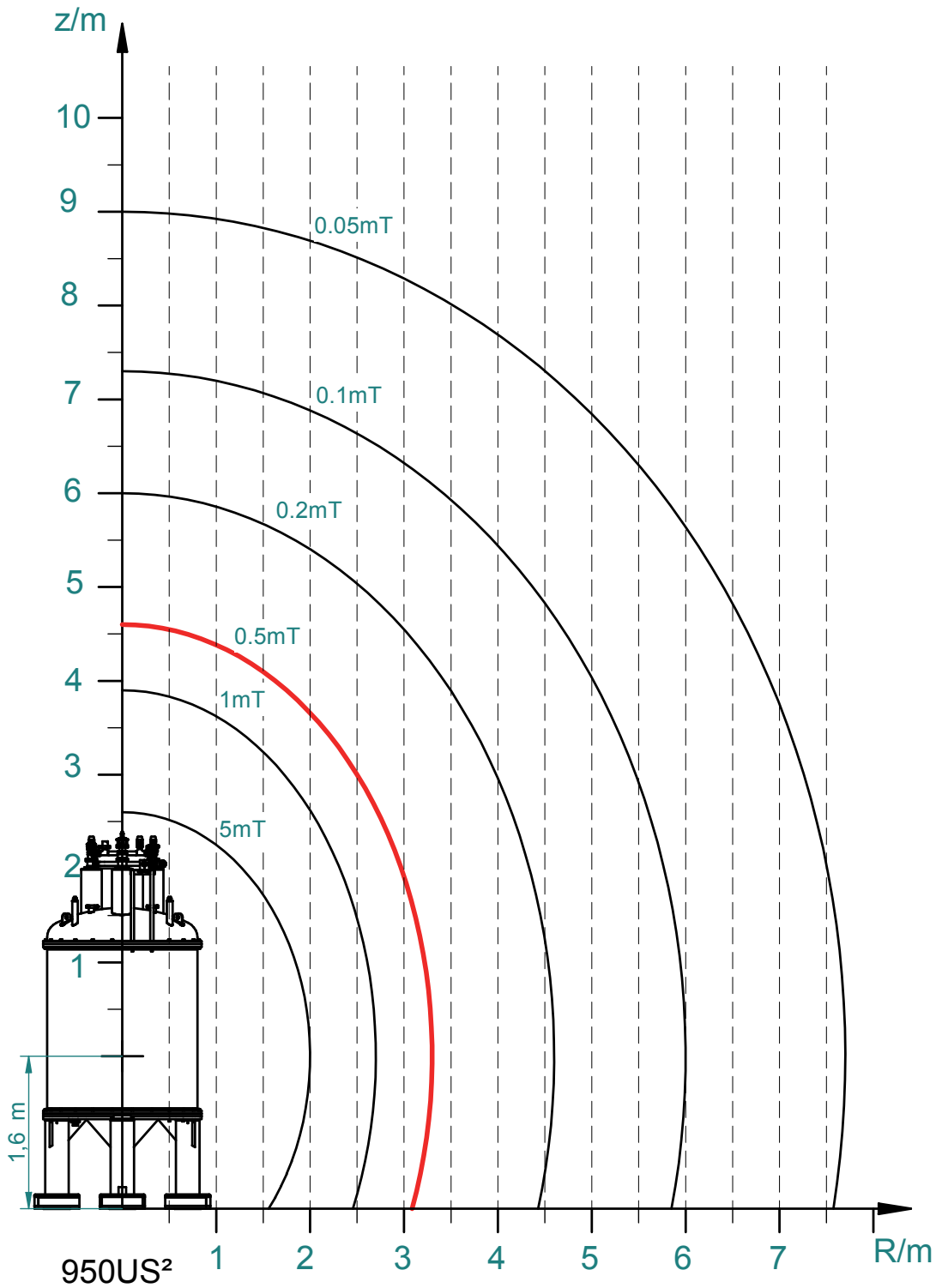

Figure 6.6: Magnetic Stray Field Plot 950 US²

7 Environment and Site Survey Measurement

This chapter covers the various site survey topics related to the NMR laboratory. The measurements and associated guidelines include:

- Vibrations
- Magnetic Environment
- Electromagnetic Interference: DC and AC EMF
- RF Interference

Note:



The results of measurements carried-out during a site survey only reflect the specific conditions that were present during the survey. Although these results are useful as a reference, they would not be conclusive for the after-the-installation system performance if one or more site conditions change. These changes may be related but not limited to sources of vibrations and electromagnetic field and RF interference like electro-mechanical equipment (HVAC, motors, pumps, freezers, etc.), elevators, car/bus/train traffic, power lines, transformers, radio/TV stations and other possible RF sources.

7.1 Vibrations

External vibrations may cause field modulations in the sample cavity. This could result in vibration sidebands, matched NMR signals that appear on either side of a main signal peak. The effect of vibrations on NMR performance will depend on the type of work being carried out, the type of system and the site building materials.

- Ideally the site should be at basement level, or on the ground floor (slab on grade), to minimize building vibrations.
- Possible sources of vibrations are generators, compressors, fans, machinery etc. Vibrations from external sources such as cars, trains, airplanes, and construction sites can also cause problems.
- Measuring the extent of vibrations at the magnet location is a relatively simple matter; if you suspect a problem you should contact your local Bruker office.

7.1.1 Vibration Guidelines

The following thresholds represent the maximum accelerations that could be tolerated on the floor of the NMR room where the magnet is going to be located.

0- 5 Hz:	5 μ g
5-10Hz:	50 μ g
10-15Hz:	100 μ g
15-20Hz:	250 μ g
> 20Hz:	350 μ g

Table 7.1: Vibration Guidelines

These values correspond to Bruker Ascend magnets equipped with advanced air piston and damped isolators (ADPI), which are effective in mitigating both vertical and horizontal vibrations.

The thresholds listed above correspond to vibration related NMR sidebands reaching the height of C13 satellites in the CHCl₃ line shape spectrum. These thresholds might not meet the needs for demanding NMR applications.

The height of vibration sidebands is approximately linear with the floor acceleration levels, meaning that an NMR application requiring smaller sidebands than the height of C13 satellites would need to have reduced floor acceleration thresholds by the same percentage factor.

Note:



It is generally recommended to have an isolated slab that separates the magnet from the rest of the floor and building. This should reduce the magnitude of vibrations that are transmitted to the magnet from the building (electromechanical equipment, HVAC, personnel, etc.). For guidelines on the magnet slab please refer to the section *Magnet Slab* [▶63].

See also

▶ [Magnet Slab](#) [▶63]

7.2 Magnetic Environment

The presence of any ferromagnetic materials in the immediate vicinity of the magnet will decrease the magnets homogeneity and may degrade overall performance. Although minimum requirements for routine NMR are not stringent, the magnetic environment must be optimized if more sophisticated experiments are being carried out. Usually, the effect of metal pipes, radiators, and other such objects can be “shimmed out”, but whenever possible, this should be avoided.

7.2.1 Guidelines for Static Objects

The next table gives a list of common sources of magnetic interference. These items should be located according to the recommendations below. It must be emphasized however, that such recommendations represent a situation that may not be achievable. Please consult with Bruker for possible solutions if one or more of these recommendations cannot be satisfied.

Object	Actual distance from magnetic center (m): Ascend Magnets	Actual distance from magnetic center (m): US ² Magnets
Steel reinforced walls	3	4
Radiators, plumbing pipes	3	4
Metal table, metal door	3	4
Filing cabinet, steel cabinet	3	4
Iron or steel beams	3	4
Massive objects, e.g. boiler	3	4

Table 7.2: Recommendations for Static Magnetic Objects

7.2.2 Guidelines for Moving Objects

The table below serves as a guideline for moveable magnetic material.

Object	Actual distance from magnetic center (m): Ascend Magnets	Actual distance from magnetic center (m): US ² Magnets
Steel cabinet doors	3	4
Large metal door, hand trolley	4	6
Elevators*	6	9
Trucks, cars, fork-lifts	9	12
Trains, subways, trams	30	30
<p>*Note: Elevators, trains and trams are more likely to be a source of vibrational interference. Note that D.C. operated elevators, trains, and trams may cause disturbances over much larger distances (see Guidelines for DC Interference [▶42]).</p>		

Table 7.3: Guidelines for Moveable Magnetic Objects

7.3 Electromagnetic Interference

Possible sources of interference are power lines which may carry fluctuating loads, heavy duty transformers, large electric motors, air conditioning systems, power transformers, etc.

The fluctuating electromagnetic fields arising from such devices can interfere with the magnet homogeneity. Of particular concern are sudden changes in load as may be produced by elevators, trams, subways etc. Other sources of interference include radio and television stations, satellites and other RF transmitters that may operate in the vicinity of NMR frequencies of interest.

If you suspect that you have a source of interference located near the proposed magnet site then you should contact Bruker Biospin for a site survey.

7.3.1 Types of EMF Interference

- DC Interference
- 50/60 Hz Interference
- RF Interference

7.3.2 DC EMF Interference

DC interference generally comes from devices operated on DC, such as elevators, trains, subways, trams, etc. The locations of both the device and its power supply & lines relative to the proposed NMR site are essential to the amplitude and orientation of DC fields and how they may interfere with the NMR system. DC feeder lines are just as disturbing as a subway, and they do not run necessarily parallel to the track.

7.3.2.1 Measuring DC Fluctuating Fields

DC EMF measurements should be conducted using a **fluxgate magnetometer**. The fluxgate sensor is capable of accurately measuring magnetic field changes below 1mG. The sensor is connected to a magnetometer, and the voltage output from the meter is then converted into digital form. The magnetic field is recorded and plotted on a computer display in real time.

7.3.2.2 Guidelines for DC Interference

When determining the effect of fluctuating magnetic fields, two parameters are important: the size of the fluctuation and the rate of change.

- Field changes of up to 5 mG, regardless of the rate of change, are generally considered harmless for standard NMR work, regardless of the NMR lock being on or off.
- Field changes larger than 5 mG will be compensated by the digital NMR lock, as long as their rate of change is less than 10 mG/sec.
- Field changes faster than 10 mG/sec need to be addressed in more detail along with the types of NMR experiments to be performed, in order to better assess whether the NMR performance will be affected. **Please consult with Bruker to assess the level of interference and explore solutions.**

The following table lists the minimum distances between the source of interference and the magnet center.

Source of Interference	Recommended Minimum Distance from Magnet Center (m)
DC trains, subways, trams*	100
DC elevators*	9
* Elevators, trains, subways, and trams are also a source of vibrational interference.	

Table 7.4: Minimum Distances from Sources of DC EMF Interference

7.3.2.3 Reducing DC Interference

The amplitude of the “full external perturbation” (peak-to-peak) is measured with the flux-gate magnetometer at the proposed magnet location but in the absence of magnet. There are two levels of compensation against these external field perturbations:

1. First, the magnet screens itself through an integrated **External Disturbance Suppression (EDS)** technology, hence only a fraction of the full perturbation is left at the magnet center. We call this residual field perturbation after magnet screening. It’s value is relevant to NMR experiments without lock, relevant to many solids experiments and high resolution experiments using gradients which require lock hold.
2. Second, the advanced digital NMR lock further minimizes the interference after magnet screening. The digital lock is less susceptible to field perturbations than the older analog lock. The final response may depend on the lock substance and concentration.

7.3.3 16-2/3 Hz and 50/60 Hz EMF Interference

Interference from 16-2/3 Hz generally comes from modern electric trains and/or streetcars that run at 16-2/3 Hz. Likewise, the 50/60 Hz interference generally comes from electrical wiring, transformers and fluorescent lights located in the vicinity of the magnet as well as near the NMR cabinet and workstation. The magnetic field further modulates this interference, increasing the likelihood of disturbances.

7.3.3.1 Measuring 16-2/3 Hz and 50/60 Hz Fluctuating Fields

The amplitude and orientation of the 16-2/3 Hz and 50/60 Hz fluctuating fields should be mapped within the proposed NMR room with power lines active using a hand-held meter. Specific locations that must be checked carefully include:

- Magnet area.
- Console area.
- Along the wall inside the NMR room at 5 cm (~2") from wall, and 3.8 cm (4") from wall.
- Approximately 5 cm (~2") below the existing lights in the room.
- Near the main outlets 230V (USA - 208V) locations in the room.

7.3.3.2 Guidelines for 16-2/3 Hz and 50/60 Hz Interference

The amplitude at which interference is likely is ~ **10 mG RMS**. Since this amplitude is based on laboratory tests, ideal values should be well below 5 mG RMS.

The magnet should not be placed within a 6 m (20') radius of a normally-sized transformer. If there is a large transformer adjacent to the proposed magnet location, measurements will be required to determine if the transformer will adversely affect NMR spectra.

Please contact Bruker if the guideline is exceeded.

7.3.3.3 Reducing 16-2/3 Hz and 50/60 Hz Interference

The amplitude of the "full external perturbation" (peak-to-peak) is measured with the flux-gate magnetometer at the proposed magnet location but in the absence of magnet. There are two levels of compensation against these external field perturbations:

1. First, the magnet screens itself through an integrated **External Disturbance Suppression (EDS)** technology, hence only a fraction of the full perturbation is left at the magnet center. We call this residual field perturbation after magnet screening. It's value is relevant to NMR experiments without lock, relevant to many solids experiments and high resolution experiments using gradients which require lock hold.
2. Second, the advanced digital NMR lock further minimizes the interference after magnet screening. The digital lock is less susceptible to field perturbations than the older analog lock. The final response may depend on the lock substance and concentration.

7.3.4 RF Interference

The NMR instrument is effectively a very sensitive radio frequency receiver. Possible sources of interference are local radio or television broadcasts, low Earth orbit satellite systems, and signals emitted by personal paging systems. Of particular concern will be interference at frequencies at which NMR experiments are carried out. Although the interference effects will depend greatly on the strength of the transmitter, as a rule of thumb only broadcasting transmitters located within a radius of approximately 5 kilometers (3 miles) are likely sources of interference.

RF interference may also occur between two or more spectrometers located in close proximity and operating at the same nominal $1H$ resonance frequency.

7.3.4.1 Measuring RF Fluctuating Fields

Radio Frequency Interference measurements should be conducted using a spectrum analyzer. The analysis should be done for the resonance frequency of each of the nuclei of interest (proportional to the $1H$ resonance frequency of the spectrometer). The minimum frequency sweep is 400 kHz.

Below is a list of the most common studied nuclei at the corresponding frequencies for the NMR systems discussed in this manual.

See also

 [Reducing RF Interference \[▶45\]](#)

7.3.4.2 Most Commonly Studied Nuclei

Nuclei	NMR Frequency (MHz)			
	800	850	900	950
1H	800.131	850.131	900.131	950.538
2H	122.827	130.502	138.177	145.915
11B	256.740	272.786	288.828	305.002
13C	201.204	213.777	226.350	239.026
15N	81.221	86.285	91.372	96.489
19F	753.003	800.055	847.113	894.551
27Al	208.647	221.687	234.718	247.862
29Si	159.147	169.094	179.037	189.063
31P	324.224	344.488	364.745	385.171

Table 7.5: List of Most Commonly Studied Nuclei and Corresponding Resonance Frequencies

7.3.4.3 Guidelines for RF Interference

As a general guideline the level of any RF interference should be less than an electrical field strength of 80 dB μ V/m/300kHz at the side of the magnet.

7.3.4.4 Reducing RF Interference

Screening a site for possible RF Interference is complicated and expensive. Shielding of the NMR room with a Faraday cage is a possible solution, though having to take such measures is quite rare.

When designing and manufacturing the Bruker spectrometers, care is taken to provide adequate shielding and the instruments rarely suffer from interference in normal RF environments. Furthermore, the advanced BSMS digital lock system - included with all Bruker AVANCE spectrometers - allows a shift in the 2H lock frequency with certain limits. This may allow enough variation in the absolute magnet field strength to shift the NMR signal away from that of local broadcasting frequencies.

RF interference may occur between two or more spectrometers located in close proximity and operating at the same nominal 1H resonance frequency. These problems can be avoided by energizing the different magnets at slightly different fields, such that their operational frequencies are separated by ~ 200 kHz of the nominal 1H resonance frequency.

8 Utility Requirements

Contents:

[Electrical Power Requirements \[▶47\]](#)

[Telecommunication \[▶49\]](#)

[Compressed Gas \[▶49\]](#)

[Water \[▶54\]](#)

[Lighting \[▶54\]](#)

[HVAC \(Heating Ventilation Air Conditioning\) \[▶54\]](#)

[Emergency Ventilation During Installation and Quenches \[▶56\]](#)

[Fire Detection System and Fire Extinguishers \[▶58\]](#)

8.1 Electrical Power Requirements

When planning the electrical power requirements of your site make provision for extra equipment which you may install, e.g. personal computers, workstations, air conditioning systems, etc.



Note: The Bruker UltraStabilized systems operate at a reduced temperature maintained by uninterrupted power to one helium pump, which would stay operational for several hours in case of a long power outage. **Although such a long power outage would lead to a slow temperature increase of the sub-cooled helium, the magnet may only experience a quench after about 10 days if no action is taken.** In this case, the system may be down for several weeks and will require reinstallation. The standard system is equipped with 9 hours of backup capacity for the magnet pump assembly. If power failures longer than 9 hours are likely in the area of installation, it is the responsibility of the customer to take appropriate provisions.

The power for the AVANCE UltraStabilized NMR systems is exclusively controlled by the BMPC unit. This unit provides the required power to the main AVANCE cabinet, the cooling pumps, and the CryoCooling unit associated with the CryoProbe system.

The flowchart included in this section displays an overview of the electrical requirements.

- Power is routed through the UPS which also has the advantage of serving as a line conditioner. In the event of a power failure, the power source automatically switches to the UPS batteries.
- If the power failure exceeds 6 minutes, the supply to the Avance cabinet and the CryoCooling unit will be cut off automatically. This will enable the UPS to power the magnet cooling pump for about 9 hours. As most (more than 90%) power failures are much shorter than 6 minutes, this compromise reserves most of the battery capacity for the magnet and allows NMR measurements to run undisturbed in case of short power interruptions.
- It is recommended to provide backup emergency power, which would not only maintain power to the magnet cooling pumps, but would also maintain power to the Avance cabinet and the CryoCooling unit, thus preventing an immediate warm-up of the CryoProbe and increasing the safety of the system. This power can come from the building's emergency generator or from a small, dedicated generator. If a power failure continues for more than 4 hours, the customer will be alarmed by telephone through the integrated monitoring system.

Utility Requirements

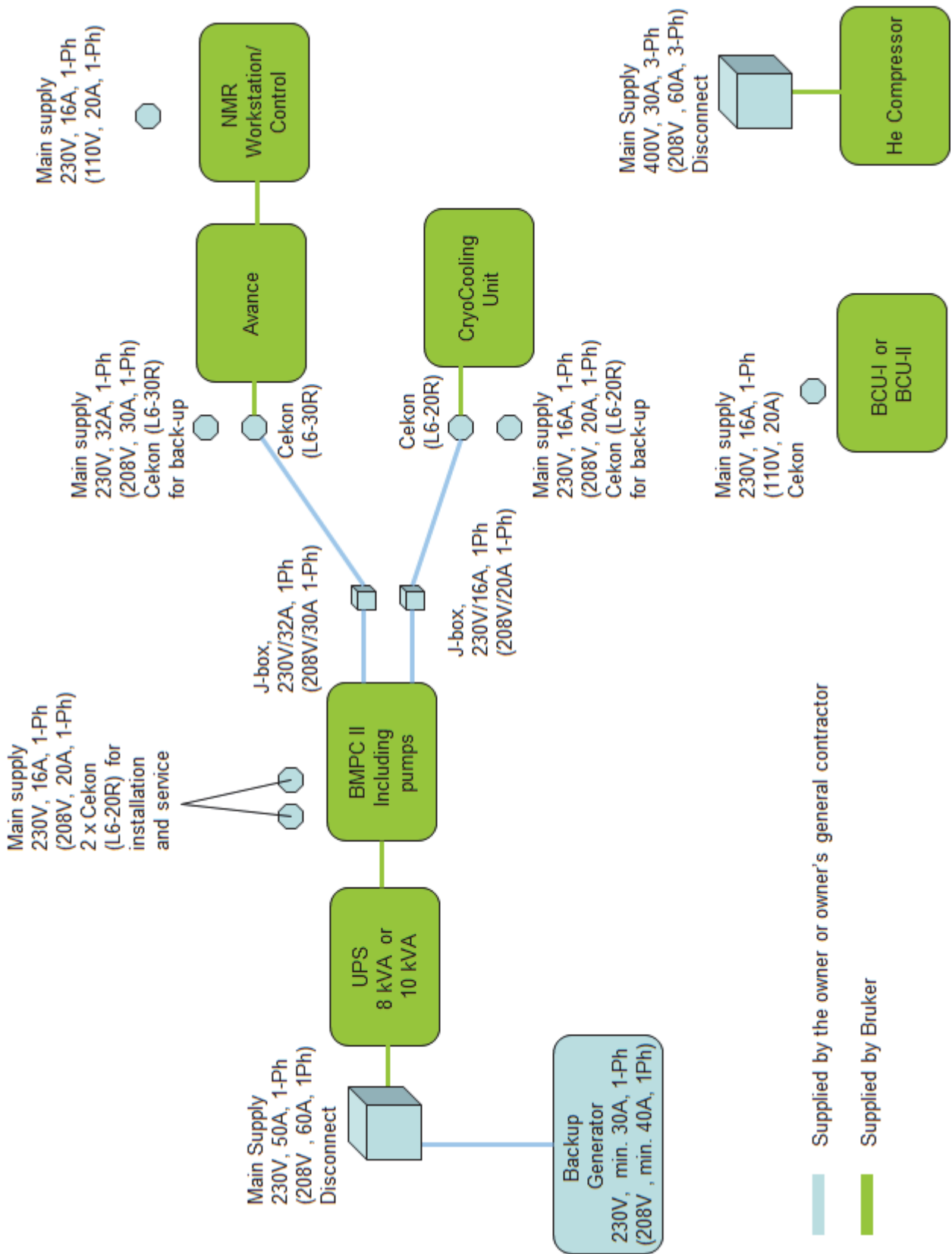

Figure 8.1: Main Electrical Power Requirements Flowchart

Some customers fit **RCCB** (residual current circuit breakers) to the spectrometer supply. These are designed to switch off the supply if there is an imbalance in the current in the live and neutral lines. If these are fitted to an AVANCE™ series spectrometer then they must be rated at 100 mA. The lower value of 30 mA commonly used is too sensitive for these spectrometers.

8.2 Telecommunication

Please refer to the AVANCE NMR layout in chapter *Floor Plan* [[▶59](#)]. The following ports/connections are required:

- Telephone/data ports behind the workstation.
- Ethernet cable between the AVANCE cabinet and the workstation.

8.3 Compressed Gas

8.3.1 General Requirements

Compressed gas line: The standard AVANCE system requires one compressed gas line with at least two regulated outputs.

Regulators: Watts Regulator R119-03C (Watts Fluid Air Company), pressure range 0-8.6 bar (0 - 125 psi), with gage head included.

- Compressed nitrogen gas needed for temperature control with VT experiments in order to achieve optimal NMR performance. For example, the BCU-I cooling unit requires a dew point of -51°C (-60°F) for the compressed gas.
- Compressed air or nitrogen gas for spinning.
- Compressed air or nitrogen gas for sample ejection, and for the magnet's vibration isolation units.
- Compressed air or nitrogen gas for the optional CryoProbe system.

8.3.2 Gas Supply

Option 1 (preferred):

Nitrogen gas only.

Option 2:

Nitrogen gas for VT work only, dry air for the rest.

Notes:

- A nitrogen separator (supplied by Bruker) can be built into the AVANCE cabinet as an available solution. This will produce the nitrogen gas required for VT work. However, this is not suitable for larger flow rates required by MAS experiments.

The nitrogen separator is suitable for use with the BCU-I cooling unit. However the nitrogen output from the separator is not pure enough and this unit should not be used with a N2 exchanger or BCU-II cooling unit for low temperature work.

- If a CryoCooling unit is to be installed, a secondary regulator, T-split from the supply line is recommended.
- The Emergency Sample Protection Device is used in conjunction with the CryoProbe system, and requires a cylinder of air or nitrogen gas.

System	Operating Pressure	Recommended Flow*
AVANCE	6-8 bar (80-120 psi)	57 l/min. (~2 cfm)
AVANCE + Sample Changer	6-8 bar (80-120 psi)	100 l/min. (~3.6 cfm)
AVANCE + MAS	6-8 bar (80-120 psi)	300 l/min. (~11 cfm)

* This is the actual consumption and minimum needed at the instrument input after the N2 supply (either a bulk tank, or a N2 separator).
For non-MAS work, if an air-compressor and N2 separator are used, the flow requirements are 50% higher, i.e. 3 cfm. (It is recommended to use a dual unit oil-less air-compressor rated at minimum double capacity of the specified requirement. Please refer to the next section on air compressors).

Table 8.1: Pressure and Flow Requirements

8.3.3 Other Specifications

Oil Content:

< 0.005 ppm (0.005 mg/m³)

Water Content:

For the BCU-I cooling unit the compressed gas should have a dew point of -51°C (-60°F). For the BCU-II cooling unit, the dew point requirement is - 80°C (-112°F).

For room temperature work and higher: Dew point of < 4°C (39.2°F).

For low temperature work: The dew point must be at least 20°C (68°F) below the operating temperature.

If a cooling unit is used, then the dew point of the compressed nitrogen should be at least 10°C (50°F) below the temperature at the heat exchanger output.

Solid Impurities:

Use 5 micron filters for high resolution NMR. For MAS probes use 1 micron filters. The filters should retain a minimum of 99.99% of the specified particles.

8.3.4 Compressed Air System

When designing a suitable compressed air system the following points must be taken into consideration:

- To prevent magnetic impurities from entering the magnet use only copper or stainless steel lines. Do not use iron or steel pipes. Plastic piping is unsuitable where very low dew points are required. Water vapor in the air will permeate plastic piping limiting minimum dew points to typically -25°C .
- To avoid surges in the air pressure (e.g. during sample lift) install a container of 10-20 liters in the air supply line to act as a buffer. Locate the buffer after the dryers in the supply line. **Buffer containers** must meet the appropriate safety requirements. They must have a working pressure of 16 bar and be proofed up to 30 bar. Use tanks which are internally coated with water and acid resistant material. This will prevent corrosion from impurities such as SO_2 .

The three major components in a suitable compressed air supply line include the compressor, dryer and appropriate filters:

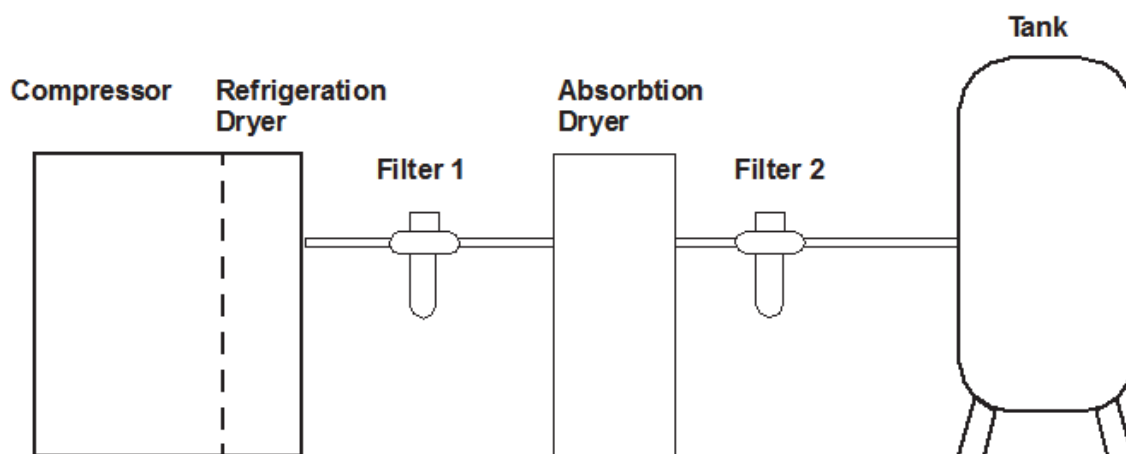

Figure 8.2: Example of a Typical Dryer/Filter System Setup

Filter 1:	General purpose liquid and dust removal filter (0.1 mg/m^3 - 0.1 ppm, 1 micron).
Filter 2:	High-efficiency dust, liquid and aerosol filter (0.1 mg/m^3 - 0.01 ppm, 1 micron).

When using a dryer/filter system setup, the following questions should be addressed:

- Pressure loss in piping?
- Efficiency loss in dryer?
- Pressure loss in filter?
- What is the required pressure?
- What is the required flow rate?

8.3.4.1 Air Compressors

When choosing an air compressor the following points should be considered:

- Ideally the compressor should be installed in a **dust free**, cool (use air conditioning as required) and dry place.
- The compressor must be **oil-free**. This can be achieved by using membrane or Teflon coated piston and scroll compressors. The compressor should be fitted with a fine dust inlet filter.
- The compressor must be capable of delivering the required flow rate and pressure suited to your particular system (see Compressed Gas Requirements). Generally the compressor should be large enough so it does not run continuously (e.g. > 50% of the time), which will cause overheating.
- The extra cost of choosing an oversized system may often be justified. The reduction in duty cycles will lower maintenance costs and extend the life of the system. A suitable compressor coupled to an adequate buffer will ensure a more **constant flow rate** leading to better performance. When spinning, the system uses a constant flow of air, but surges will occur during sample lift. When referring to Compressed Gas Requirements you should add on 10 l/min. to the average consumption if the system is fitted with anti-vibration devices such as pneumatic dampers or a VIP system.
- Take into account the **pressure loss** along the line between the compressor and the final gate valve. The pressure drop depends on the pipe diameters. An internal diameter of 8 mm has been found to be suitable. The plastic tubing used to carry the supply from the final gate valve to the console has an outside diameter of 8 mm and is supplied by Bruker.
- Some types of **dryers**, e.g., absorption dryers can use up to 25% of the air flow to regenerate the drying material. If this type of dryer is used then the output capacity of the compressor must be sufficient to supply this requirement.
- Many compressors are fitted with dryer and a tray to collect **excess water**. Regular checking of the dryer and emptying of the water collector will ensure trouble free operation. This arrangement is quite satisfactory in environments with normal humidity (< 80%). However in areas of higher humidity (> 80%) a cooling coil with an automatic water drain must be fitted to the compressor outlet. This will ensure that filters do not become overloaded.
- Although not directly concerned with air quality, compressors are a **source of vibrations** which may interfere with NMR performance. You should consider using a compressor fitted with a vibration damping housing if it is to be situated close to the spectrometer. The output noise level should be < 75 dBA.

8.3.4.2 Dryers

8.3.4.2.1 Refrigeration Dryers

This type of dryer removes moisture from gas by cooling to within a few degrees of the freezing point of water. The condensed moisture is removed in a separator and drain trap mechanism located immediately downstream of the dryer. This drain should be valve switched automatically.

Advantages

- None of the compressed gas is wasted in regeneration which is more suitable if the capacity of the compressor is marginal.
- Maintenance free.

- Not as susceptible to oil mist contamination as adsorption dryers, thus do not have the same need for pre-filters.

Disadvantage

- These type of dryers are limited because of their inability to produce very low dew points. The recommended dew point for room temperature work of 4°C is only just achievable. Therefore if low temperature NMR is to be carried out, this type of dryer is unsuitable.

8.3.4.2.2 Absorbtion Dryers

The air is passed through cartridges of synthetic zeolite known as Molecular Sieves. The sieves are hygroscopic and retain water molecules when air is passed through them. Two sieves are normally used alternatively. A portion of the dry air output of sieve A is fed into sieve B to regenerate it. The amount used in regeneration is typically 15% but up to 25% may be required for very low dewpoints. The process is automatically reversed at regular intervals with the output of sieve B used to regenerate sieve A.

Advantages

- Much lower dew points are achievable compared to refrigeration dryers.
- Automatic Regeneration: Normally the sieves will last for many years if they do not become contaminated with oil, e.g. from mist in the air.
- The drying agent may be easily replaced.

Disadvantages

- Up to 25% of throughput is used to achieve the automatic regeneration.
- Requires the use of more dust filters.
- Filters at the input (oil < 0.01 mg/m³) are required due to the susceptibility to oil contamination from mist in the air.
- The use of absorption dryers may lead to the generation of dust and so the dried air output must be fed through an appropriate filter (1 micron).
- These dryers require more maintenance than refrigeration dryers.
- They can be noisy when switching between the two cartridges.
- Due to the different absorption rates of nitrogen and oxygen the **N₂/O₂ composition** may change. To prevent this an absorption dryer should be placed between the compressor and buffer tank.

8.3.4.3 Filters

Micro-filters must be fitted as the last element in the supply line. For specification see the section [Other Specifications](#) [[▶50](#)].

Absorption dryers are prone to oil contamination and as such the input must be fitted with a oil filter (oil < 0.01 mg/m³ 99.9% removal efficiency). To protect the dryers, regardless of type, you are advised to install a water filter and an oil filter between the compressor and the dryer. Adsorption dryers may generate dust and may need extra dust filters at the output..

The output of refrigeration dryers must be fed through a carbon activated filter.

Water filters must be fitted with automatic water drains as opposed to manual drains. The use of valve switched drains is strongly recommended. Floater switched drains have a tendency to become jammed and hence require regular maintenance.

If you are particularly concerned about oil contamination in the air supply then you must consider using a submicron filter followed by an activated charcoal filter as this combination is particularly effective in removing oil.

8.4 Water

If the system is equipped with the CryoProbe option and the compressor is water cooled, then cooling water is needed to remove the ca. 7.5 kW of heat output from the water-cooled type He compressor used in conjunction with the CryoProbe. The cooling water requirements for the CryoProbe system are found in the chapter *CryoProbe and Other Accessories* [▶73]CryoProbe Utility Requirements.

8.5 Lighting

Operation is most convenient when the computer monitor(s) may be viewed under subdued lighting. However, normal office lighting will be needed in other areas of the NMR room. The most convenient arrangement is to have separately switchable lights using standard light bulbs. Make sure that reflections from strong artificial light do not fall upon the monitor screen. Care should also be taken to minimize reflections from sources such as windows.

- Do not direct spotlights toward the magnet; this could change the surface temperature.
- Consideration should be given to the relative placement of lights to the air conditioning inputs, which mostly contain the temperature sensors for the air conditioners. Otherwise the switching of lights might result in a system over-reaction and a considerable temperature change.
- Lights are generally not recommended within a radius of 2 meters from the magnet.

8.6 HVAC (Heating Ventilation Air Conditioning)

Constant air pressure, temperature and humidity is crucial for high performance operation. Ideally, an absolute room temperature of between 17-25°C should be kept.

Room should not fluctuate more than +/- 0.5°C per 24 hours near the magnet or cabinets. Even with small changes within this narrow range, it is essential that these are random and there is **no periodicity of temperature changes**. Air drafts, particularly those created from air conditioning or heating systems, can have negative effects on the magnet, thus the location and orientation of air-diffusers must prevent the air from blowing towards the magnet and spectrometer cabinet. If possible, it is recommended to have the exhaust (air-return) closer to the NMR spectrometer equipment (AVANCE console, UPS, CryoCooling unit, BCU-I) that releases most of the heat output into the space. This would help with removing the heat closer to its sources and ultimately help with the overall temperature stability in the room.



Note: When NMR Lock is on and when Autoshim is used, the room should not fluctuate more than +/- 1.5 °C per 24 hours.

Humidity should be kept between **30% and 80%**. Conditions other than these may warrant the installation of an air conditioner with appropriate humidity controls.

See also

📖 [Emergency Ventilation During Installation and Quenches](#) ▶ [56](#)

8.6.1 Heat Output

Most of the heat is generated by the system electronics, the magnet itself does not dissipate any heat.

The following table lists the heat generated by various systems:

System	Heat Generated
AVANCE TwoBay (with 3 channels & BCU-I)	2.5 kW
AVANCE TwoBay (configured for solids)	5.0 kW
Imaging Cabinet	2.4 kW
BMPC II (high frequency systems only)	1.25 kW
BCU-I, BCU-II	BCU-I: 0.5 kW BCU-II: 2.4 kW
Gradient Chiller	0.5 kW
CryoCooling Unit	0.8 kW
He Compressor (note: heat from the outdoor He compressor is not dissipated inside the room)	0.5 kW - residual
He Compressor CryoProbe - indoor water-cooled	0.5 kW
He Compressor CryoProbe - outdoor air-cooled	8.5 kW

Table 8.2: Heat Generated by Typical AVANCE Systems

8.6.2 System Stability

Air Temperature

The heat output is constant and it is essential to minimize or avoid short term oscillations of the HVAC system, and provide a continuous slow flow of air that in turn reduces the speed of any temperature changes. It is recommended to have a continuous and slow exchange of air in the NMR room, hence minimizing fluctuations.

Air Diffuser and Return Ducts

- Avoid any air drafts in the room, especially towards the magnet or system electronics.
- Use low velocity diffusers or a perforated duct (e.g. a duct sock).
- In order to remove heat directly from the source it is recommended placing the air return ducts closer to the rear side of the system electronics.

Atmospheric Pressure Changes

Rapid changes in the temperature may result in atmospheric pressure changes. High atmospheric pressure could reduce the helium boil off if the magnet cryostat is not equipped with an electronic atmospheric pressure device. The boil-off rate could be even lower than the minimum value which could be measured by the flow meter. **Electronic Atmospheric Pressure Devices (EAPD)**, which, for example, holds the pressure at 1030 HPa, stabilize field drift and helium boil-off when changes in atmospheric pressure occur.

The atmospheric pressure device is included as standard with all Ultra-High Field magnet systems.

8.7 Emergency Ventilation During Installation and Quenches

Due to the large amount of liquid helium contained in the magnet, an emergency exhaust system may be required to prevent O₂ depletion during a magnet quench.

Likewise, during the installation, refilling and cooling of superconducting magnets, large volumes of nitrogen or helium gases may be generated under certain conditions. Although these gases are inert, if generated in large enough quantities, they can displace the oxygen in the room causing potential danger of suffocation.

The following table lists the amount of liquid helium and helium gas after a quench:

UltraStabilized Magnets	Amount Liquid Helium (liters)	Helium Gas After a Quench
Ascend 800, Ascend 850	~ 350	260 m ³ (~9,200 ft ³)
900 US ² , 950 US ²	~ 1400	1000 m ³ (~35,300 ft ³)
850WB US ² , 900WB US ²	~ 1400	1000 m ³ (~35,300 ft ³)

Table 8.3: Helium Gas After a Quench

Regarding the emergency gas exhaust, important considerations include, but are not limited to, the following:

- **Amount of liquid helium:** Taking the 850 WB US² magnet as an example, the total amount of liquid helium is 1400 liters. In case of a quench, the liquid transforms into gas and expands by a factor of 740. Therefore, the total amount of helium evaporated gas in case of a quench will be ca. 1000 m³ (35,300 ft³).
- **Maximum helium gas flow:** The maximum flow of helium gas is calculated on the assumption that half of the volume of liquid evaporates in 1 minute, thus the maximum flow would be 500 m³ (17,650 ft³) for the 850 WB US² magnet. The gas should be removed from the room immediately through an emergency exhaust system.
- **O₂ level sensors:** Oxygen level sensors are required to detect low O₂ levels within the NMR room for each system. One sensor is needed above the magnet for detecting low O₂ levels due to He gas exhaust in case of a quench or during He fills. An additional sensor is needed close to the floor for detecting low O₂ levels due to N₂ gas exhaust during magnet cooling or regular N₂ fills. In case of placing the magnet inside a pit, a third sensor is needed inside a pit to detect low O₂ levels from N₂ gas.

8.7.1 Emergency Exhaust Solutions

In many cases doors and windows will provide sufficient ventilation in larger rooms. It is important to compare the volume of helium gas that would be released after a quench and the space volume of the NMR magnet room, in order to determine the optimum and practical solution for emergency ventilation. Generically it is recommended that an emergency exhaust system be installed in smaller rooms, or rooms not connected to the outside. The following exhaust solutions are recommended:

Passive Exhaust

This system is based on louvers in the ceiling, or upper parts of outside walls, that open up due to the pressure of helium gas.

Active Exhaust

In addition, an active system based on a purge fan and exhaust duct close to the ceiling is recommended. This way, adequate exhaust of cryogenic gases will be provided not only during a quench, but also during the initial cooling of the magnet and regular cryogen refills.

Normally it is sufficient to operate this fan manually, as the probability of an unattended quench after the installation is rather low.

If desired, this fan can be operated with an automatic switch:

- It may be connected to the O₂ sensors so it turns on automatically when the O₂ level drops below the safety set point.
- It should be installed in addition to a manual switch.
- Measures should be taken to prevent it from being turned on during a fire.

Quench Pipes

This solution may be needed as a **last resort solution** when the NMR room is small and **any of the other options are not sufficient** to ensure safety after a magnet quench.

This solution is based on a pipe connected directly to the magnet, which is then routed to the outside of the building. It is important to note the following:

- The helium exhaust from the magnet should be vented directly to the outside of the building.
- The ducts should have sufficient diameter to avoid excessive pressure build-up due to the flow impedance of the duct.
- The location of the exit end of the duct must not be accessible to anyone other than service personnel. In addition the exit opening should be protected from the ingress of rain, snow, animals, etc.
- It is also essential that any gas which vents from the exhaust duct cannot be drawn into the air conditioning or ventilation system intakes. The location of the duct's output should be carefully sited to prevent this from happening during any adverse atmospheric conditions and winds.
- Insulation of exhaust piping should also be provided to prevent cold burns and O₂ condensation during a quench.



Please contact Bruker if the implementation of quench pipes is planned!

Pits

When a magnet is installed in a pit, it is important to ensure there is continuous air-flow (exhaust) within the pit. This is done to prevent any buildup of nitrogen gas in the confines of the pit. A low exhaust down in the pit is recommended. Additional emergency ventilation may also be necessary, particularly if the pit is >1.09m (3.5') deep (average mouth-height of a person). Since nitrogen gas cannot be detected by the human senses, an oxygen sensor mounted in the pit will trigger an increased rate of exhaust.

Exhaust for Ceiling Soffits

A soffit is a hole that has been cut in the ceiling to facilitate cryogen fills and/or the magnet installation. Though it is not required to install ventilation in a soffit, it is important to understand that the soffit will be the first area to fill up with helium gas during a quench or during a helium fill. It is important to elicit extra caution in this case.

A passive louver or an exhaust duct with fan are practical solutions when soffits are used.

Air Conditioning as an Exhaust

It is recommended that the air conditioning system be adequate to dissipate the sudden gas buildup during a quench. In addition the air conditioning must have a safety feature which **draws all the air out** of the room and **brings fresh air** in during a quench, rather than just recirculating the old air through the system. The air conditioning system could, for example, be connected to an oxygen level sensor.

Please contact Bruker for further information on exhaust solutions.

See also

 [HVAC \(Heating Ventilation Air Conditioning\) \[▶54\]](#)

8.8 Fire Detection System and Fire Extinguishers

Rooms containing NMR magnets should be equipped with **temperature sensors** for fire detection. These must respond *only* to a sudden rise of temperature, and not be triggered by a quench (sudden drop of temperature).

Optical sensors cannot discriminate between smoke from a fire and fog caused by a quench so these may not be used.

Fire extinguishers in the vicinity of the magnet room must be **non-magnetic** (stainless steel or aluminum). It is the obligation of the customer to inform the local fire department about the dangers of magnetic fields. These magnets stay at field for a long time even in a most blazing fire!

Ceiling sprinkler heads should be made of metal instead of glass. A quench could falsely trigger the alcohol-filled glass vials, which can shatter in the presence of cold helium gas. Sprinklers should not be located directly over the magnet.

Any sprinkler lines or other metal pipes located above the magnet should be thermally-insulated to prevent O₂ condensation or water freezing in the line from the large amount of cold He gas following a magnet quench.

A **pre-action sprinkler system** is recommended, as it is not loaded with water, but is activated through an interlock mechanism enabling the water to fill the lines in case of a fire.

9 Floor Plan

9.1 Size and Mass of Equipment

The floor of the NMR room must be sufficiently strong to support the console, magnet, and ancillary equipment. The following tables provide the dimensions and weights of NMR equipment, and the footprint and weight of magnets (filled with cryogens and including stand). The floor should also be as rigid as possible to reduce the effect of vibrations.

Component	Width (m)	Depth (m)	Height (m)	Weight (kg)
AVANCE TwoBay	1.31	0.83	1.55	454
Table / Workstation	1.20	1.00	0.75	68
MicroImaging Cabinet	0.69	0.83	1.55	205 / 150
BCU-I	0.50	0.55	0.48	46
BCU-II	0.55	0.59	0.74	74
BMPC II	0.70	0.85	1.70	254
For the CryoProbe option refer to <i>CryoProbe and Other Accessories</i> [73].				

Table 9.1: Dimensions and Weights of NMR Equipment

See also

 [CryoProbe and Other Accessories](#) [[73](#)]

9.1.1 Magnet Dimensions

The values in the following table correspond to the following figure:

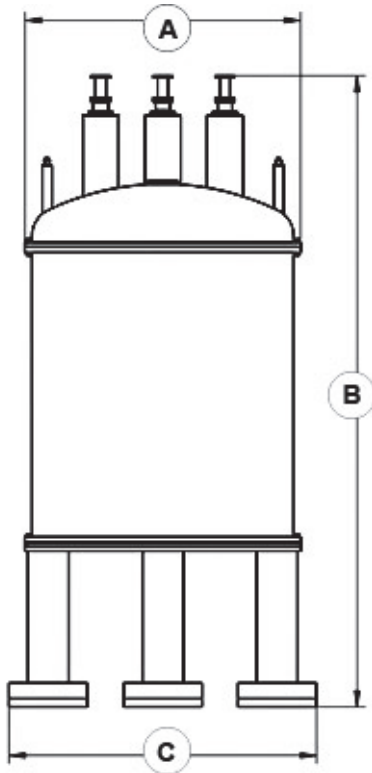

Figure 9.1: Magnet Dimensions

A.	Maximum magnet diameter
B.	Magnet height from the floor, including stand.
C.	Overall footprint diameter
<i>Refer to the Magnet Dimensions and Total Weights table for the values of A, B, and C.</i>	

9.1.2 Magnet Dimensions and Total Weight

Magnet	A Maximum Magnet Diameter (m)	B Magnet Height from the Floor Including Stand (m)	C Overall Footprint (m ²)	Total Magnet Weight incl. Stand & Cryogenics (kg)
Ascend 800	1.280	3.084	~3.0	3,500
Ascend 850	1.280	3.084	~3.0	3,500
850 WB US ²	1.688	3.865	~3.54	7,200
900 US ²	1.688	3.865	~3.54	7,200
900 WB US ²	1.688	3.865	~3.54	7,200
950 US ²	1.688	3.865	~3.54	7,200
US ² = UltraShield-UltraStabilized; WB = Wide Bore (89 mm)				

Table 9.2: Magnet Dimensions and Total Weight

9.2 Magnet Location

When locating the magnet, certain considerations must be made with regards to the laboratory environment:

- To increase magnet homogeneity, the magnet should be located away from permanent iron structures such as support beams in walls and floors. Reference: [Electromagnetic Interference \[▶41\]](#).
- To increase temperature stability, the magnet should not be placed in direct sunlight or near any artificial heat source. The magnet should also not be placed under or in close proximity to air-vents or in an area that experiences air drafts. Air should not be blown directly down or towards the NMR magnet.
- When possible, avoid a situation where a significant stray field (>5 G / 0.5 mT) extends into adjacent rooms.
- There should be free access to the magnet from all sides.

It is important to determine the optimal position in the NMR room, based on the following orientation elements:

- **The front of the manifold:** The front of the helium manifold is defined by a U-shaped opening. The manifold connects the two (or three) helium turrets at the top of the magnet.
- **The helium fill port:** The left turret (when looking at the front of the magnet) is the helium fill port. It is necessary to provide a path to either the left side or the front of the magnet so liquid helium transport dewars can be rolled in place.
- **Magnet pump line:** The magnet pump line connects to the back of the manifold (see [Figure 9.2 \[▶62\]](#)).
- **The front of the stand:** The magnet stand also has a front side. The CryoProbe™ transfer lines coming from the “Cryo” unit connect to the probe on the front side of the magnet stand. The shim cable comes out through the back side, 180 degrees apart from the CryoProbe transfer lines.

NOTE: The front of the magnet stand does not necessarily have to match the front of the manifold.

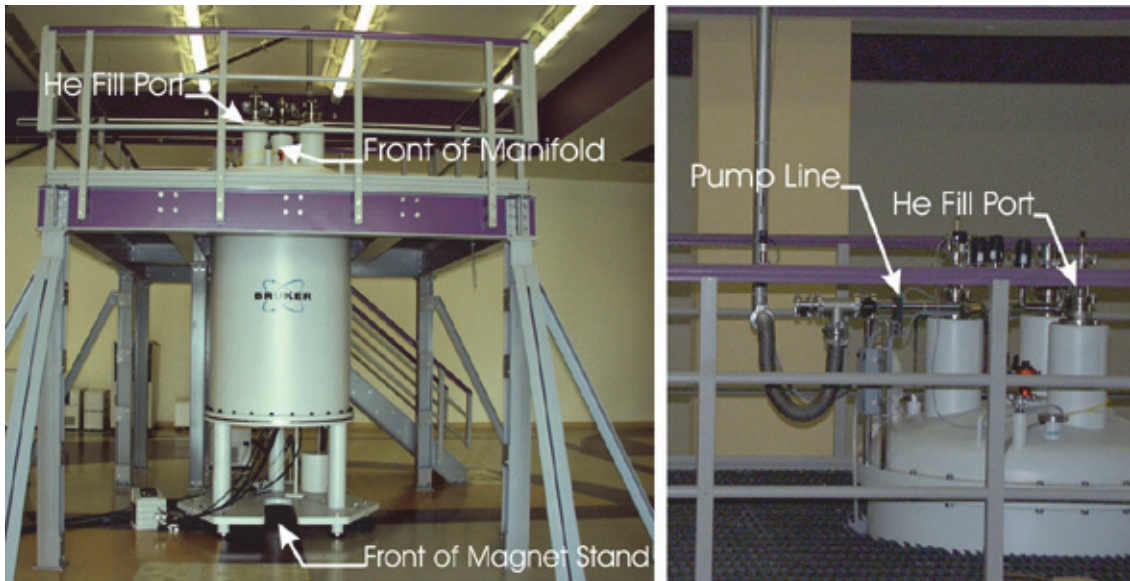

Figure 9.2: Magnet Orientation

9.3 Floor Load

The floor must be sufficiently strong to support the mass of the equipment, plus the weight of any installation devices, e.g. forklifts, hoists etc. The floor must also be as rigid as possible to reduce the effects of vibration.

The overall floor load may be calculated from the total magnet weight distributed over the overall footprint of the magnet.

The Ascend 800/850 magnets are supported by a total of 9 small pads (3 pads per post), each pad having a diameter of 66 mm. The larger US2 magnets are supported by a total of 3 larger pads (one per post), each pad having a diameter of 280 mm. The maximum point load may be calculated by the total weight of the magnet distributed over the total contact area of the supporting pads.

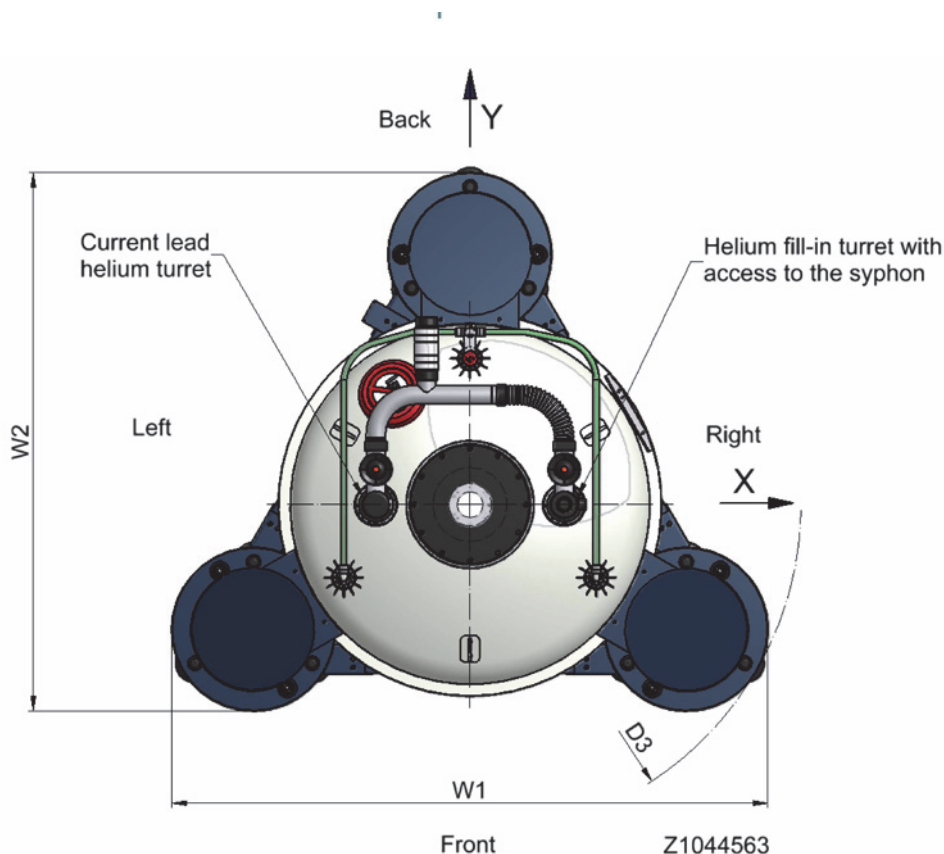

Figure 9.3: Top View of an Ascend Magnet

9.3.1 Magnet Slab

In larger buildings, it is recommended to design an isolated magnet slab that separates (isolates) the magnet from the rest of the floor and building. This reduces vibrations that are transmitted to the magnet from the building (electromechanical equipment, HVAC, personnel, etc.). The slab must be large and strong enough to safely support the load of the magnet.

The recommended dimensions for a possible magnet slab are as follows:

Magnet	Length	Width	Depth
Ascend 800, Ascend 850	3.6 m (12')	3.6 m (12')	0.3 m (1')
850WB, 900US ² , 900 WB US ² , 950 US ²	3.6 m (12')	3.6 m (12')	0.6 m (2')

Table 9.3: Recommended Magnet Slab Dimensions

NOTE: These dimensions are guidelines, not specifications, and remain subject to approval by the project's structural engineer.

Reinforcement: It is recommended to use non-magnetic reinforcement (e.g. fiberglass, or non-magnetic stainless steel).

An isolated slab may not be necessary if the structure contains no sources of vibrations, or if the foundation is on bedrock. In this case, it is still recommended to perform a vibration analysis. Please consult with Bruker regarding the magnet slab and to arrange for analysis.

Refer to *Vibrations* [▶ 39] for more information on vibration isolation and site analysis.

9.4 Floor Types

Generally a **liquid nitrogen resistant floor material** must be used, such as PVC or wood that has been painted or varnished. Unfinished wood must not be used as this will absorb liquid nitrogen. This also implies that wood floors must be regularly maintained to help prevent absorption.

Many of the system components contain highly sensitive electronic devices that must be protected from **Electrostatic Discharge** (ESD) by proper floor covering and grounding practices.

To prevent ESD damage in the magnet room, the system must be installed on an ESD resistant flooring such as vinyl, and properly grounded. One of the most important characteristics of an **ESD resistant floor** is its ability to conduct charges to ground. The second most important aspect is its **anti-static property**.

9.5 Magnet Platform

The purpose of a platform is provide safe access to the top of the magnet for sample insertion, cryogen fills, etc. The basic design requirements for the platform include, but are not limited to the following:

Material:	It must be non-magnetic. Wood, aluminum, or composite (fiber) materials are generally used.
Height of platform deck:	For the tall US ² magnets, the top of the deck must be located approximately at 2.44m (8') above the finished floor. The Ascend 800/850 magnets do not require a platform given their compact size. An aluminum rolling ladder is sufficient for these compact magnets.
Railing:	The height of the railing will be determined by local building codes. However, if the ceiling height is low it may be necessary to make a section of the railing removable. When the gantry is used to pick the magnet off the air skates, the cross-bar must not crush the railings.
Footprint:	The total footprint of the platform should be large enough to accommodate a person, but small enough that the helium transfer line will reach across the footprint without trouble. A footprint of 4m x 4m without taking into account the stairs is generally adequate.
Opening diameter:	The circular opening must be centered with the magnet and have a diameter of 1.7m (67") for the US ² magnets. This will leave ca. 5 cm (2") clearance around the magnet cryostat, not the flanges. The diameter at the flanges is larger (please refer to the maximum magnet diameter identified with „A“ in Figure 9.1 and corresponding Table 9.2.
Border around magnet opening and outer platform rim:	Borders are recommended to prevent anything from falling off the magnet platform.

Support Posts:	Given the larger magnet diameter at the flanges relative to the opening in the platform, care should be used when designing the support post to prevent obstructions. It is recommended to have the support posts away from the magnet and closer to the outside perimeter of the platform to provide optimal access to the bottom of the magnet and allow sufficient clearances for accessories.
Stairs:	The access stairs shall be positioned to allow easy access to the front of the upper manifold. This facilitates sample insertion.
Magnet assembly time:	The magnet will be slid into place, and then a hydraulic gantry will be used to assemble the magnet. For this reason, it is recommended to construct the platform in two parts. The first piece can be installed before the magnet is delivered. The second piece should be installed shortly after the magnet has been assembled. Please refer to the installation Overview [▶83] for the stages of installation.

Table 9.4: Basic Design Requirements for Magnet Platforms

**Note:**

The Ascend 800 and 850 do not necessarily require a platform.

See also

 [Rigging Equipment \[▶24\]](#)

9.6 Magnet Pits

When the magnet must be sited in an existing magnet pit, pay attention to the following:

- Special rigging equipment and a temporary platform to support and lower magnet inside the pit.
- Continuous ventilation and emergency exhaust inside the pit (please refer to special notes related to pits in sections *HVAC (Heating Ventilation Air Conditioning)* [[54](#)] and *Emergency Ventilation During Installation and Quenches* [[56](#)]).
- Magnet refills and access for transport dewars.
- Cable lengths.
- Siting the BCU-I or BCU-II cooling unit.
- Siting the CryoPlatform™.

Consult your local Bruker Installation Engineer for details.

9.7 Magnet Pump Line

This section briefly describes the purpose, fabrication, and route of the pump line.

Purpose

The pump line connects the pump to the Joule Thompson cooling unit located inside the helium dewar of the magnet system. The pump line connects the rear side of the helium manifold to the BMPC II cabinet.

Ascend 800 and 850

The BMPC II is placed right next to the magnet. A standard pump line is delivered with the system.

850WB US², 900 US², 900WB US² and 950 US²

It is custom-made out of stainless steel to fit site requirements.

Most of the time it runs across the floor, although sometimes it is partially elevated:

- Keeping the pump line at floor level is the preferred route as it is the most efficient way to prevent vibrations from entering the magnet. The pump line runs down to the floor near the magnet stand, then continues across the floor to the wall. It runs along the wall to the BMPC II. A 15 x 15 cm (6 x 6") trench would be sufficient to conceal the pump line and sensor cable.
- It is always important to design the route to avoid tripping and obstructions, and to protect the physical integrity of the pump line at all times.

9.8 Maximum Field Strengths for NMR Equipment

Once the location of the magnet has been decided, it is time to determine where the remainder of the equipment will be placed. Protection of motors and electronics from magnetic stray fields is crucial.

Unit	Maximum Field Strength
AVANCE cabinet	1.0 mT (10 G) line
BCU-I, BCU-II	5.0 mT (50 G) - max. 2.7m from magnet center
LCD computer monitor*	1.0 mT (10 G)
Computers e.g. NMR workstation, PC	0.5 mT (5 G)
Printer, plotter	0.5 mT (5 G)
BMPC II	1.0 mT (10 G)
CryoProbe system components (e.g. He steel cylinder and its transport path)	0.5 mT (5 G)
CryoCooling unit	5.0 mT (50 G)
He compressor (CryoCooling)	0.5 mT (5 G)
Gas cylinders	0.5 mT (5 G)
Heavy metal office furniture e.g. filing cabinet**	0.5 mT (5 G) - not recommended in magnet room
Movable metal chair	Not recommended in magnet room
* The working place for personnel should be outside the 0.5 mT (5 G) line. An additional LCD monitor and keyboard can be located at the 1.0 mT (10 G) line for probe adjustments etc.	
** Use wooden furniture if access during critical measurements is required.	

Table 9.5: Maximum Field Strength for NMR Equipment

9.9 Automation Considerations

Bruker **sample changers** have been developed for most magnet systems. These sample changer's multiple NMR sample tubes and can be used in conjunction with any of the low or high field magnets. The sample changers utilize mechanical mounting equipment to attach the sample changer to the magnet. This allows for easy sample changer adjustment in X, Y, and Z directions.

Contact Bruker for site considerations if planning on any other automation options.

9.10 Cabinet Position

The various units within the AVANCE™ cabinet, especially the acquisition computer, must be kept at a minimum distance from the magnet. Protection of the acquisition computer and digital electronics from the magnet's stray field is best achieved by positioning the cabinet so that the acquisition computer is no closer than the 1.0 mT (10 G) line. Any ancillary cabinets such as microimaging must also be placed outside the 1.0 mT (10 G) line. To allow adequate ventilation for the cabinet, it must be positioned no closer than 30 cm from the back of the cabinet to any walls. For service access to the rear, there must be sufficient space for the cabinet to be pulled out from the wall. For ease of cabling, locate electrical outlets and compressed air supply close to the rear of the cabinet.

See also

 [Maximum Field Strengths for NMR Equipment \[▶67\]](#)

9.11 Worktable Position

Magnetic storage devices are sensitive to the stray field and attention must be given to their position relative to the magnet.

- The workstation and additional disks, CD-ROM drives, etc., which are normally placed on the worktable, should not be exposed to fields greater than 1.0 mT (10 G).
- For convenience of operation, no direct light should fall on the LCD panel, nor should there be a strong light source at the back of the panel. A separate dimmer or at least partial switching is recommended for the lights in the worktable area.

9.12 Service Access Requirements

The following recommendations will ensure that there is sufficient space for accessing the system, as well as providing adequate ventilation:

- Ventilation: A minimum of 30 cm must be left between the back of the cabinet and any wall to ensure proper ventilation.
- Service access - AVANCE: Sufficient space (~ 60 cm) must be left in front of the AVANCE so the cabinet may be pulled away from the wall for service. Service access to the sides is not required.
- Service access - Magnet: There must be enough space between the magnet legs and the wall such that a service person can walk all the way around the magnet. Also, when refilling the cryogen levels, large dewars must be brought close to the magnet. Ensure that the magnet room is suitably spacious to allow easy access for the dewars. If a platform is not used then there must also be enough room for a ladder. As a rule of thumb the magnet must be accessible to a distance of 2 m over at least half of its circumference and be no closer than 0.8 m to the nearest wall.

The following are miscellaneous, but important things to think about when creating a workable floor plan:

- For ease of cabling, locate electrical outlets and compressed air supply close to the rear of the cabinet and by the magnet.
- The door to the magnet room must be easily accessible from all parts of the room. It is advantageous to have the doors located so that traffic through the room does not approach the magnet.
- As a rule gas cylinders must be stored outside the room. If for any reason they must be placed in the magnet room located as far away from the magnet as possible and secured properly to a wall well outside the 5 Gauss.
- Ensure that convenient and safe pathways are available so that cryogen transport dewars can easily be moved into and out of the magnet room. This includes making sure that the cryogen dewars do not run over cabling, and that the equipment/furniture is located to allow for access.
- Make provision for sample/solvent preparation and storage space, documentation storage space, personal computers, printer/plotter tables, workstations etc.
- Under no circumstances should movable office chairs made of magnetic material be used in the NMR room.

- Make provision for installing a telephone and lines for, e.g. Internet access. It is most convenient if the operator can use the phone while sitting at the spectrometer worktable.

Finally, before a final layout is decided, consider future equipment that may need to be installed. Remember that once installed, the magnet must not be moved.

Layout Examples

The following layout examples of some NMR systems include the equipment and utilities. A description of each of the NMR system components is presented in the chapter [Equipment \[17\]](#), while the details regarding the utility requirements are presented in the chapter [Utility Requirements \[47\]](#).

The next table refers to the numbered items in the sample site layouts that follow.

Device	No.	International	America	Purpose/Comments
UPS	#1	230V, 50/60Hz 50A 1-Ph	208V, 60Hz, 60A, 1-Ph	Disconnect, on emergency power.
BMPC II	#2	230V, 50/60Hz, 16A 1-Ph	208V, 60Hz, 20A, 1-Ph, L6-20R	For installation and service.
	#3	230V, 50/60Hz, 16A 1-Ph	208V, 60Hz, 20A, 1-Ph, L6-20R	
	#4	J-box, 230V, 32A, 1Ph	J-box 208V, 30A 1-Ph	Conduit to power the AVANCE from the BMPC II.
	#5	J-box, 230V, 16A, 1Ph	J-box 208V, 20A 1-Ph	Conduit to power the CryoCooling unit from BMPC II.
	#6	Analog fax modem line.		
AVANCE	#7	Receptacle termination of wire-in conduit coming from J-box, 230V, 32A	L6-30R termination of wire-in conduit coming from J-box, 208V, 30A	Power the AVANCE from the BMPC II.
	#8	230V, 50/60Hz, 30A, 1-Ph	208V, 60Hz, 30A, 1-Ph, L6-30R	For back-up.
	#9	Regulated compressed gas 6.9 bar (100 psi).		
BCU-I or BCU-II	#10	230V, 50/60Hz, 16A 1-Ph	110V, 60Hz, 20A	On separate UPS.
Cryo Cooling Unit	#11	Receptacle termination of wire-in conduit coming from J-box, 230V, 16A	L6-20R termination of wire-in conduit coming from J-box, 208V, 20A	Power the CryoCooling unit from the BMPC II.
	#12	230V, 50/60Hz, 16A, 1-Ph	208V, 60Hz, 20A, 1-Ph, L6-20R	For back-up.
	#13	Regulated compressed gas 4.1 bar (60 psi)		
He Compressor	#14	400V, 50Hz, 30A (fused), 3-Ph or 480V, 60Hz, 30A (fused), 3-Ph	208V, 60Hz, 60A (fused), 3-Ph	Disconnect, on emergency power.
Workstation	#15	230V, 50/60Hz, 16A, 1-Ph	110V, 20A, 1-Ph	On separate UPS.
	#16	Telephone port		
	#17	Data port		
Imaging Accessory	#18	230, 50/60Hz, 30A, 1-Ph	208V, 60Hz, 30A, 1-Ph	Optional cabinet.

Table 9.6: Utility Requirements

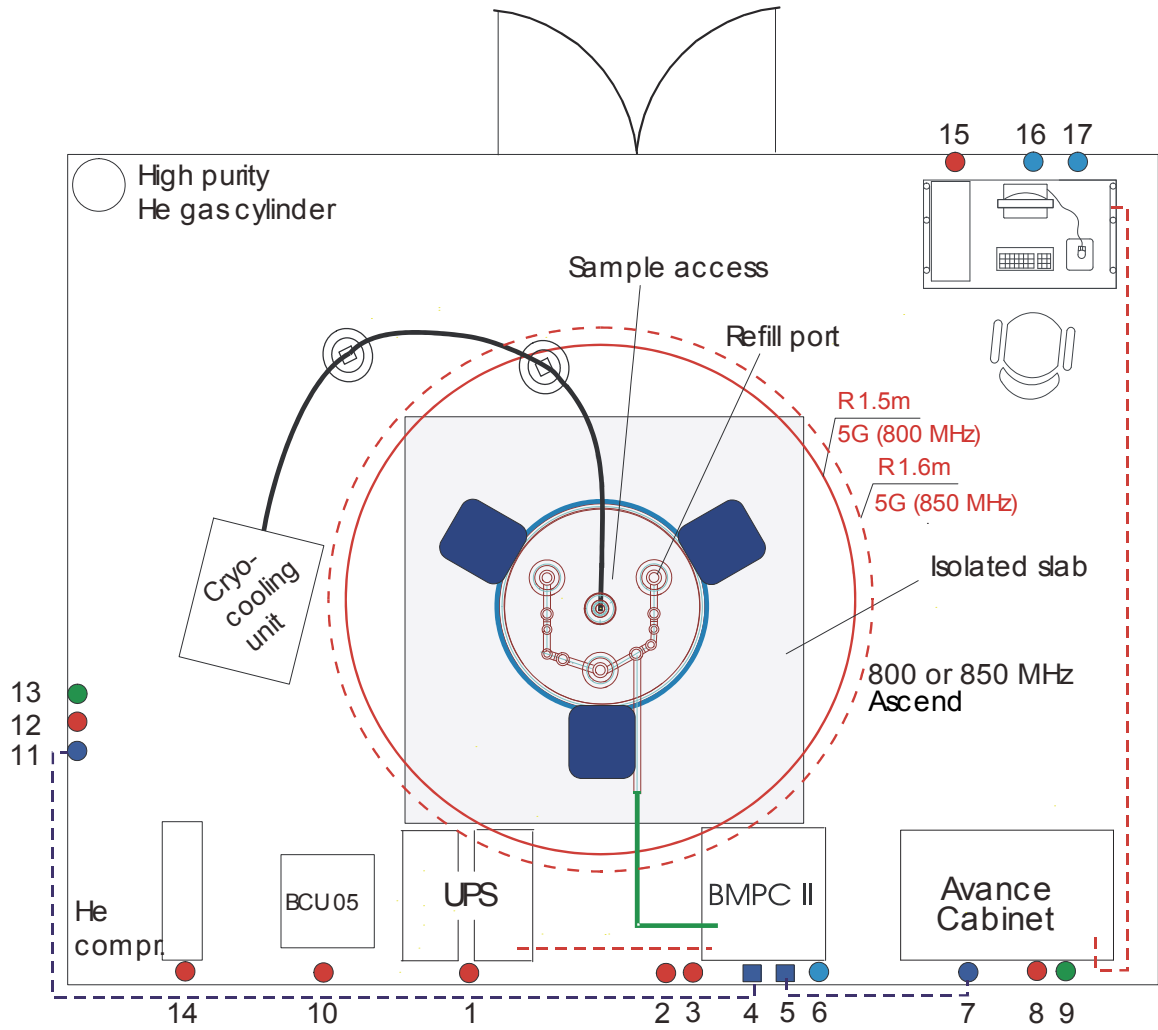

Figure 9.4: Ascend 800 and 850 NMR Layout Example

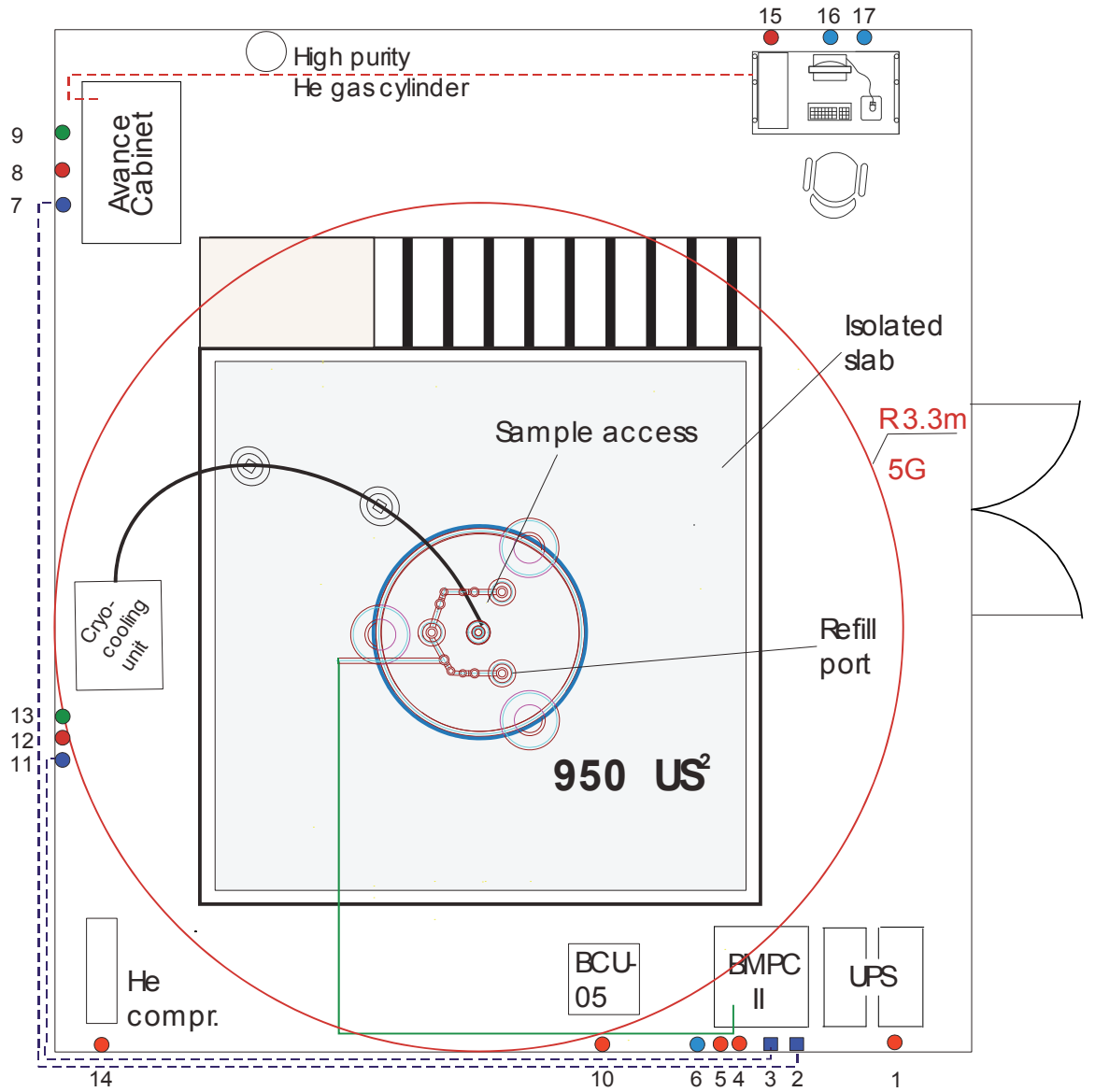

Figure 9.5: AVANCE 950 US² NMR Layout Example

10 CryoProbe and Other Accessories

The CryoProbe accessory for the AVANCE™ Series NMR Spectrometers offers dramatic increases in signal to noise ratio (S/N) by reducing the operating temperature of the NMR coil assembly and the preamplifier.

The CryoProbe accessory consists of two major components: the CryoProbe and the CryoPlatform. The CryoProbe is similar to a standard probe, however contains cryogenically cooled RF coil and electronics. The CryoPlatform, which provides cryogenic cooling for the CryoProbe, is made up of:

- CryoCooling Unit with control electronics.
- Helium Compressor (along with any associated cooling equipment).
- Helium Gas Cylinder (for purging of the CryoProbe).
- Helium transfer lines and transfer line support.

The CryoCooling Unit must be sited adjacent to the magnet, whereas the Helium Compressor and Helium Gas Cylinder may be sited remotely. The first step in the site planning involves review of the magnet area to determine if floor space is available to accommodate the CryoCooling Unit. The CryoCooling Unit is optimally located level with the magnet. Other configurations, such as magnet pits that can not accommodate the CryoCooling Unit, require special consideration.

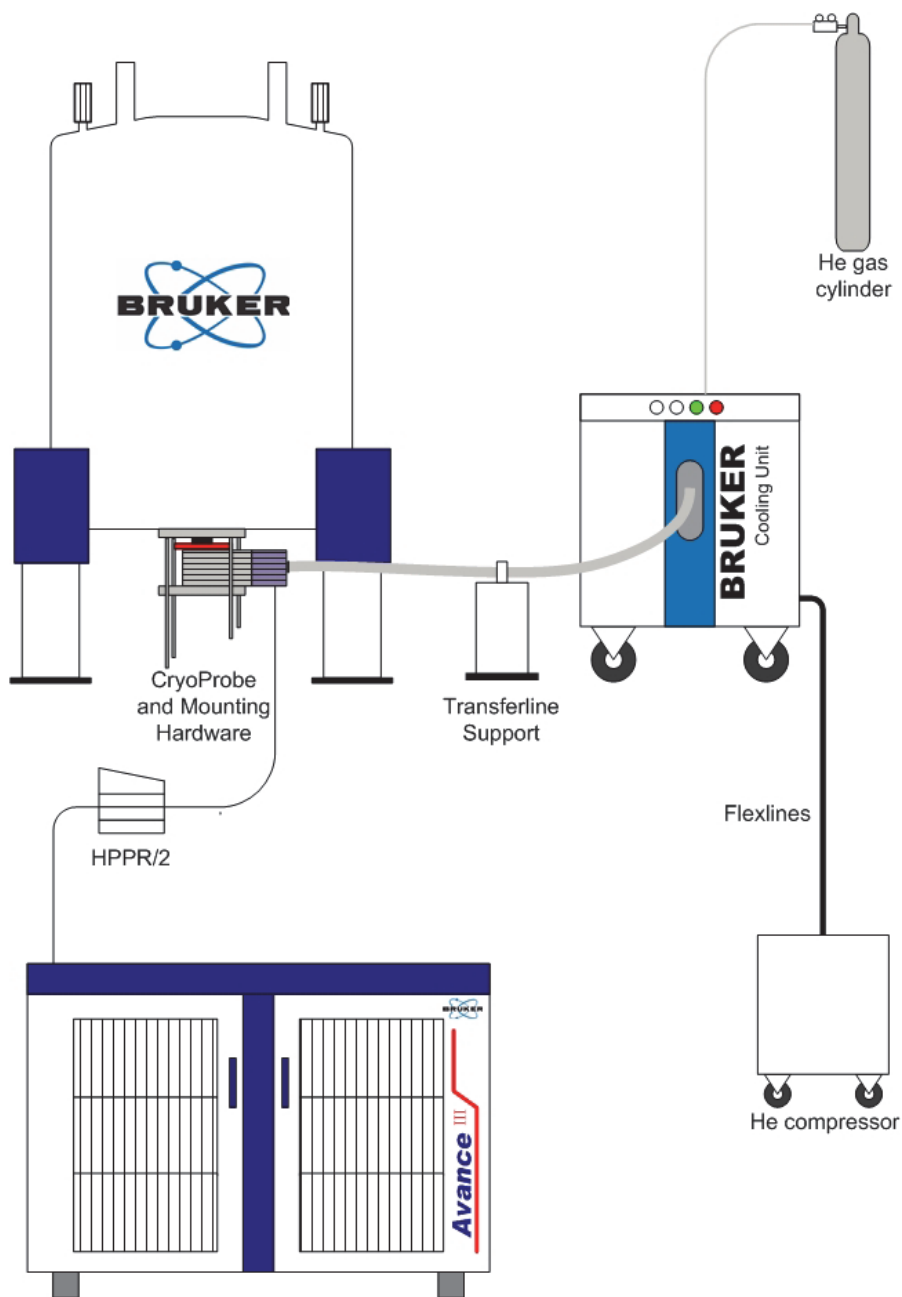

Figure 10.1: CryoProbe System Overview

Refer to the layout examples for more information.

10.1 CryoCooling Unit

The CryoCooling Unit is installed adjacent to the magnet outside the 50 Gauss (5 mT) line. The shim cable must be 180° from the CryoProbe front plate. The shim stack may be rotated if necessary.

Dimensions:	Width: 68 cm Depth: 89 cm Height: 96 cm
Weight:	400 kg
Voltage:	230 V AC +/- 10%, 1 phase, 50-60 Hz.
Required external fuse upstream:	T 10 A (T = time-lag fuse)
Power consumption:	Peak 0.8 kW Average 0.5 kW (systems produced before June 2005: peak power of 1.5 kW)
Acoustic noise:	Maximum 61 dB(A) 2 meters distant
Maximum room ambient temperature:	30°C. No operation above this temperature is approved.
Helium gas supply:	A high purity helium (He) gas cylinder (6 N = 99.9999% or better, maximum impurity concentration 1 ppm).
Compressed air or nitrogen supply:	With a pressure of > or = to 4.5 bar.
Position:	Outside 50 Gauss (5 mT) stray field.

Table 10.1: CryoCooling Unit Specifications

10.2 Helium Compressors

The next step in the site planning for a CryoProbe accessory involves determining the type and location of the helium compressor. Since the helium compressor generates a considerable amount of heat (7.5 kW average, 8.5 kW peak), it must be cooled to prevent overheating. Bruker offers both water cooled and air cooled helium compressors. In either case, placing the compressor in a remote room (up to 20 meters away) or an enclosure will keep the noise of the unit out of your laboratory. Outdoor helium compressors may be sited up to 40 meters from the CryoCooling Unit.

10.2.1 Available Models

Three models of helium compressors are currently available. All the compressors must be sited outside the 5 Gauss (0.5 mT) line, generate the same amount of heat (7.5 kW average) and have the same power requirements (3 Phase, 208 V). The correct helium compressor for your laboratory may be determined based on the desired location for the unit (indoor, outdoor, and distance from the CryoCooling Unit) and the availability of a chilled water supply. Helium transfer lines connect the helium compressor to the CryoCooling unit and are available in several different lengths as shown below.

10.2.1.1 Helium Compressor - Indoor Water Cooled

- Requires chilled water source (supplied by customer) with a flow of ≥ 420 L/Hr, incoming temperature $\leq 25^\circ\text{C}$. Caution: Do not use demineralized or deionized water.
- Ambient operating temperature $5\text{--}28^\circ\text{C}$.

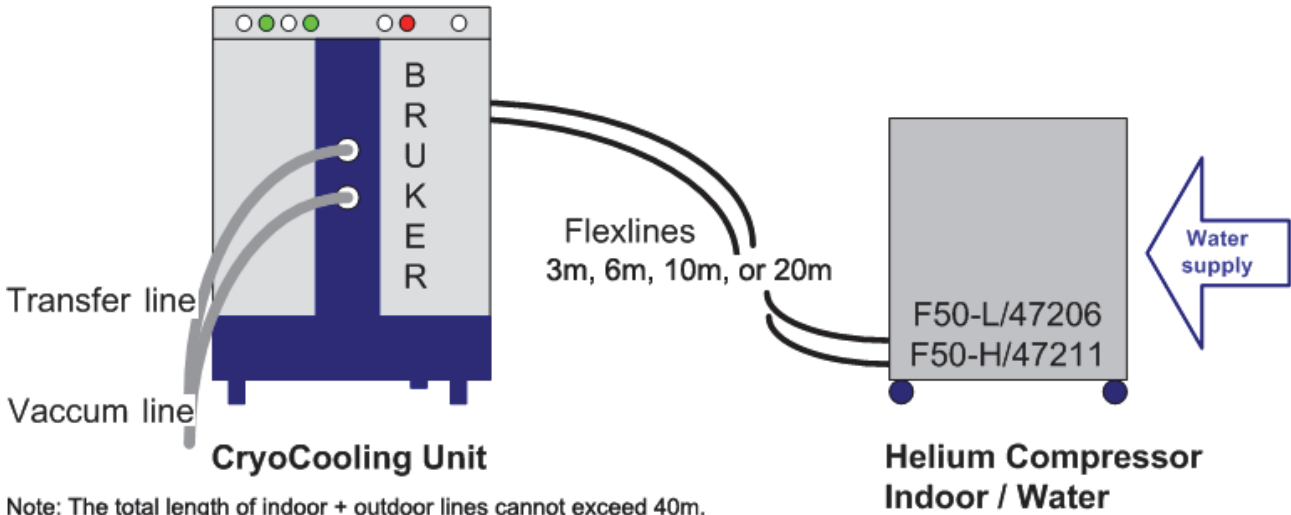

Note: The total length of indoor + outdoor lines cannot exceed 40m.

Figure 10.2: Helium Compressor - Indoor Water Cooled

10.2.1.2 Helium Compressor - Indoor Air Cooled

- The room air handling system must be able to dissipate 7.5 kW of heat. The low power version (400 MHz systems only) requires dissipation of 4.8 kW.
- Siting this helium compressor in the same room as the NMR is not recommended.
- Ambient operating temperature $5\text{--}28^\circ\text{C}$.

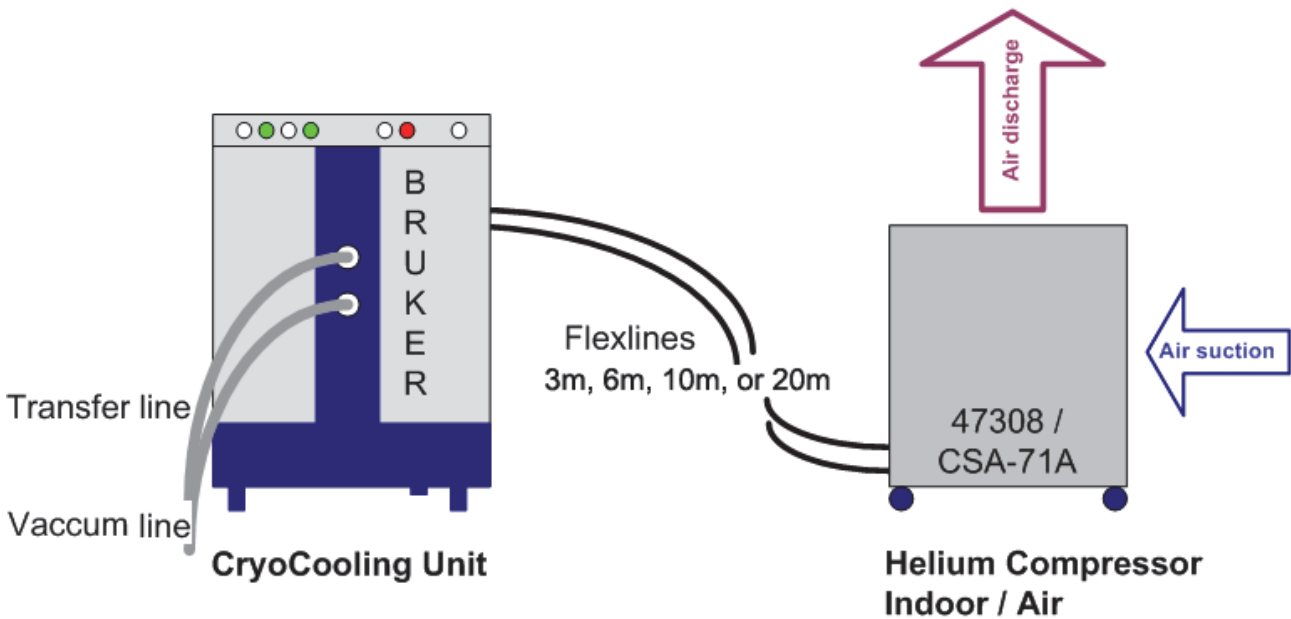

Note: The total length of indoor + outdoor lines cannot exceed 40m.

Figure 10.3: Helium Compressor - Indoor Air Cooled

10.2.1.3 Helium Compressor - Outdoor Air Cooled

- The Outdoor Air Cooled helium compressor consists of an Outdoor Unit and an Indoor Unit.
- The outdoor unit is specified to operate between the temperatures of -30°C to 45°C .

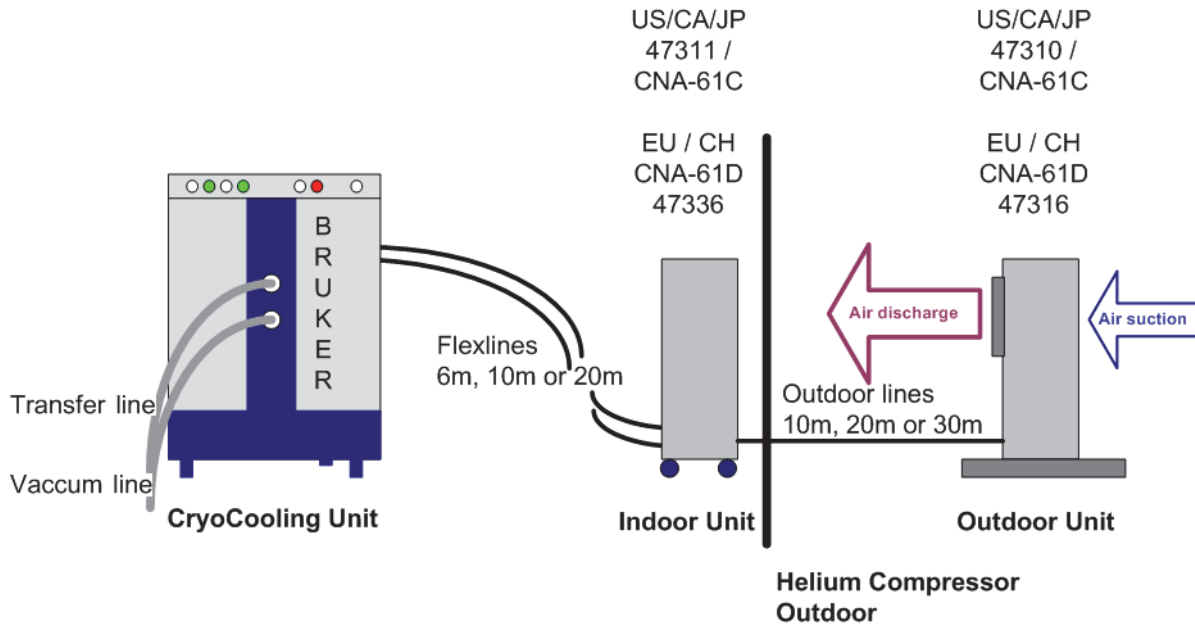

Figure 10.4: Helium Compressor - Outdoor Air Cooled

10.2.2 Space Requirements and Specifications

10.2.2.1 Indoor Helium Compressors

The indoor helium compressors (air or water cooled) have space requirements to allow for air-flow and servicing the unit. The minimum room space needed is 1.25 m (width) x 0.8 m (depth) x 0.7 m (height).

Sumitomo Type:	F-50L	F-50H	CSA-71A
Type of Compressor:	Water-cooled	Water-cooled	Air-cooled
Dimension:	Width: 45 cm Depth: 48.5 cm Height: 59.1 cm	Width: 45 cm Depth: 48.5 cm Height: 59.1 cm	Width: 55 cm Depth: 55 cm Height: 88.5 cm
Weight:	120 kg	120 kg	140 kg
Voltage:	3 x 200 V	3 x 400 V (380, 400, 415 @ 50 Hz, or 460, 480 @ 60 Hz)	3 x 200 V @ 50/60 Hz US no plug supplied
Mainly delivered to:	USA/CA/JP	EU/CH	USA/CA/JP
Operating Current:	26 A	13 A	25 A
Minimum Circuit Am- pacity:	35 A	17 A	35 A
Maximum Fuse Size:	60 A	30 A	60 A

Sumitomo Type:	F-50L	F-50H	CSA-71A
Compressor LRA:	160 A	75 A	100 A
Power Requirements			
Minimum:	9 kVA	9 kVA	9 kVA
Recommended:	12 kVA	12 kVA	12 kVA
Power Consumption			
Cool Down max. 50/60 Hz:	7.2/8.3 kW	7.2/8.3 kW	7.2/8.3 kW
Steady State max. 50/60 Hz:	6.5/7.5 kW	6.5/7.5 kW	6.5/7.2 kW
Water supply to remove the heat load (cooling power > 8.3 kW):	Flow: 420 l/hour Temperature: 4-28°C Water Quality: PH 6.5-8.2 Hardness: mg[CaCo3]/l < 200 Molybdate-reactive silicate: < 50 mg/l Suspended matter: < 10 mg/l Maximum pressure: < 7 bar (100 PSI)		---
Helium Gas Supply:	A high purity helium (He) gas cylinder (6 N = 99.9999% or better, maximum impurity concentration 1 ppm).		
Acoustic Noise:	Maximum 60 dB(A), 2 meters distant.		
Ambient Operating Temperature:	5 to 28°C (41 to 82.4°F)		30°C

Table 10.2: Technical Data for Indoor Compressors

10.2.2.2 Outdoor Helium Compressors

The outdoor helium compressor has an outdoor and an indoor unit. Each component has space requirements for airflow and servicing.

The **indoor** component requires a space of 0.5 m (width) x 1.3 m (depth) x 1 m (height).

The **outdoor** component requires a space of 1.4 m (width) x 1.7 m (depth) x 1.25 m (height), and should be sited on a concrete slab.

Sumitomo Type:	CNA-61C		CNA-61D
Type of Compressor:	Air		Air
Dimension:	Width: 91 cm Depth: 405 cm Height: 105 cm	Width: 27 cm Depth: 575 cm Height: 63 cm	Width: 91 cm Depth: 40 cm Height: 105 cm
Weight:	115 kg	45 kg	115 kg
Voltage:	3 x 200 V		3 x 400 V
Mainly delivered to:	USA/CA/JP		EU/CH
Operating Current:	27 A		13 A
Minimum Circuit Am- capacity:	50 A		30 A

Sumitomo Type:	CNA-61C		CNA-61D
Maximum Fuse/Circuit Breaker Size:	50 A		30 A
Compressor LRA:	156 A		74 A
Power Requirements			
Minimum:	11 kVA		11 kVA
Recommended:	14 kVA		14 kVA
Power Consumption			
Cool Down max. 50/60 Hz:	8.0/9.2 kW 7.5/8.5 kW		8.0/9.2 kW 7.5/8.5 kW
Steady State max. 50/60 Hz:			
Acoustic Noise:	Maximum 66 dB(A), outdoor unit only.		
Ambient Operating Temperature:	-30 to 45°C (-22 to 113°F)	5 to 28°C (41 to 82.4°F)	-30 to 45°C (-22 to 113°F)

Table 10.3: Technical Data for Outdoor Compressors

10.3 Helium Cylinders

The next step in the site planning for a CryoProbe accessory involves determining the location for the helium gas cylinder. A research grade helium cylinder (grade 6.0, 99.9999%) is supplied by the customer and is connected to the CryoCooling unit. The cylinder must be outside the 5 Gauss line in a serviceable location (i.e. changing the bottle should not interfere with nearby magnets). The helium regulator is supplied by Bruker.

Two lengths of helium gas line are available (10 m and 20 m).

The helium compressor and helium gas cylinder may be sited in a remote room or in the same room as the spectrometer as shown in the layout examples.

10.4 Summary of CryoProbe Options

Helium Compressors (3 Options)

- Indoor Air Cooled
- Indoor Water Cooled
- Outdoor Air Cooled

Helium Gas Transfer Lines

For Indoor Helium Compressors (3 Options)

- 6 m
- 10 m
- 20 m

For Outdoor Helium Compressors (11 Options)

- 3 m indoor line / 10 m outdoor line
- 3 m indoor line / 20 m outdoor line
- 3 m indoor line / 30 m outdoor line
- 6 m indoor line / 10 m outdoor line
- 6 m indoor line / 20 m outdoor line
- 6 m indoor line / 30 m outdoor line
- 10 m indoor line / 10 m outdoor line
- 10 m indoor line / 20 m outdoor line
- 10 m indoor line / 30 m outdoor line
- 20 m indoor line / 10 m outdoor line
- 20 m indoor line / 20 m outdoor line

Helium Cylinder High Pressure Gas Line (2 Options)

- 10 m
- 20 m

Helium Transfer line from CryoCooling Unit to CryoProbe

- A standard length transfer line, determined by the magnet, is delivered with each CryoPlatform. Longer transfer lines may be ordered if necessary to accommodate the CryoCooling unit in your laboratory. If a longer transfer line is required a special review of your site will be required.

CryoPlatform

CryoCooling Unit

- Located outside 50 Gauss (5 mT) line.
- Must be serviceable from all sides.
- Must be at least 0.5 meters from walls on all sides.

Helium Compressor- Indoor Water or Air Cooled

- Located outside 5 Gauss line.
- Minimum room space is 1.25 m (width) x 0.8 m (depth) x 0.7 m (height).
- Must be serviceable from top and left side.
- The distance between the CryoCooling unit and the helium compressor component is defined by the helium transfer lines ordered.
- Chilled water lines must be supplied to helium compressor (water cooled unit only).
- Ambient operating temperature 5°–28°C.



Note:

The indoor helium compressor has rollers and is connected to flexible helium transfer lines. Water-cooled models are additionally connected to water lines supplied by the customer (typically high pressure flexible water tubing).

Helium Compressor - Outdoor Air Cooled

- Consists of one small indoor unit, one outdoor unit, and transfer lines connecting the units.
- Requires indoor space of 0.5 m (width) x 1.3 m (depth) x 1 m (height).
- Requires outdoor space of 1.4 m (width) x 1.7 m (depth) x 1.25 m (height).
- The distance between the CryoCooling unit and the two helium compressor components is defined by the transfer lines ordered.
- Ambient operating temperature for outdoor components is -30–45°C.

Helium Cylinder

- The distance between the CryoCooling unit and the helium cylinder is defined by the gas line ordered.
- Must be in a serviceable location (to change cylinder and not interfere with magnet).

11 Installation

All the general requirements such as power supply, compressed air supply, etc. which were discussed in the preceding chapters must first be arranged before taking delivery of the system. It must be stressed that any installation requirements listed below such as cryogen supplies, are **in addition** to those needed for normal system operation.

Where necessary the customer is advised to contact the local Port Authorities to clarify arrangements for custom clearance. If the transport crates must be opened you must first contact Bruker, as the crates are shipped utilizing Shockwatch™ and Tiltwatch™. Failure to do this may invalidate the warranty. If the transport crates are opened for any reason they must then be stored indoors (out of direct sunlight).

11.1 Overview

The spectrometer system will arrive at the site in crates. The crates should only be opened by the Bruker BioSpin service engineer. The commissioning of the magnet involves several stages as outlined in the table below. The installation time line given below is an approximation; each site is slightly different.

Days	Procedures
Day 1	Delivery of the magnet.
Days 2 - 5	Assembly of the magnet.
Days 6 - 12	Flushing, vacuum, leak detection, installation of the pump line.
Days 13 - 17	Precooling with liquid N ₂ .
Days 18 - 19	Cooling with liquid He.
Days 20 - 23	Sub-cooling to reduced temperature.
Days 24 - 38	Energizing and Cryo-shimming.
Days 38 - 48	Running NMR experiments to demonstrate standard specifications.

Table 11.1: Overview of Magnet Commissioning

11.2 Accessibility

Before the arrival on site, the customer must ensure the equipment can be delivered, and transported safely to the final location inside the NMR room.

- Ensure that doorways, passageways and lifts have sufficient clearance.
- Extra large doorways are required for the larger magnets.
- A crane is needed outside for unloading the magnet.
- Special air-skates or rollers are needed for magnet transport.
- Lifting equipment such as forklifts or hydraulic pallet jacks are necessary for transporting accessories.

See also

 [Magnet Access and Rigging \[▶21\]](#)

11.3 Installation Requirements Checklist

For the installation the customer must provide the following:

For the installation the customer must provide the following:	
Lifting equipment and minimum ceiling height as outlined in the table in Charging the Magnet [▶85] . Pallet jack and/or fork lift for transporting system accessories.	—
Two cylinders of N ₂ gas 50l/200 bar (~2 cu.ft, 3000 psi) with reducing regulator valves to deliver pressure of 0.5 bar (~8 psi), as specified in Other Specifications [▶50] .	—
Six cylinders of He gas 50l/200 bar (~2 cu.ft, 3000 psi) with reducing regulator valves to deliver a pressure of 0.2 bar (~3 psi), as specified in the section Other Specifications [▶50] .	—
Quantities of liquid helium and nitrogen as specified in the table in Charging the Magnet [▶85] .	—
Liquid helium and nitrogen transport dewars as specified in Compressed Gas [▶49] .	—
One power outlet 230V/16A (USA 208V/30A) single phase and two more 230V/16A (USA 208V/20A) single phase power outlets are needed to run a vacuum pump, a heat gun, and a power supply unit. These power outlets must be available in addition to the main power source used to run the spectrometer.	—
When a hydraulic lifting system is needed, one power outlet 3 phase 400V/16A (USA 3 phase 208V/20A).	—
Step ladder (non-magnetic e.g. aluminum, fiberglass, or wood).	—
Where possible the customer should provide the following: <ul style="list-style-type: none"> ▪ Heat gun or hand held hair dryer (min. 1200 W). ▪ Roughing pump 10⁻² mbar (14.5 x 10⁻⁵ psi). ▪ Pair of insulated gloves. ▪ Electric screwdriver. 	—
Larger systems may require a platform to access the top of the magnet with opening suitable for magnet placement. Please refer to Magnet Platform [▶64] for more details.	—

Table 11.2: Installation Requirements Checklist

11.4 Installation Procedure

The various steps and procedures mentioned in the [Overview \[▶83\]](#) will be discussed in detail in the following sections.

11.4.1 Magnet Assembly

When the magnet is delivered (do not uncrate it!) it must first be assembled by the installation engineer. The assembly area must be clean, dry and free of dust.

The assembly may require that the engineer works beneath the magnet and thus special rigging equipment is required. Refer to the section [Magnet Access and Rigging \[▶21\]](#) for special equipment requirements for assembly.

See also

- 📖 [Overview \[▶83\]](#)
- 📖 [Charging the Magnet \[▶85\]](#)

11.4.2 Magnet Evacuation and Flushing with Nitrogen Gas

Once the magnet has been assembled and placed in the magnet room, rough pumping of the cryostat can begin. At the same time the cryostat is flushed through with dry nitrogen gas. The customer must provide a 50l/200 bar (~2 cu.ft, 3000 psi) cylinder of dry nitrogen gas (99.9999% purity). The cylinder should be fitted with a secondary regulator valve to deliver a pressure of 0.5 bar (~8 psi).

For some installations the customer is asked to provide a roughing pump, e.g. rotary pump capable of reducing pressures within the cryostat to 10^{-3} mbar. Further pumping of the cryostat is then carried out to reduce the internal pressure to 10^{-6} mbar. It is convenient, if the customer can provide a suitable pump such as a diffusion or turbo pump. Where no such pump is available then it can be supplied by Bruker.

11.4.3 Cooling the Magnet to Liquid Nitrogen Temperatures

This next stage involves filling the magnet with liquid nitrogen. The quantity of liquid nitrogen required is listed in the table in the [Overview \[▶83\]](#). The transfer dewars used for precool generally have a capacity of 250 - 500 liters (attention: maximum pressure < 0.5 bar) with a fixture for pressuring and transferring via a stainless steel or corrugated plastic tube of 10 mm (~3/8") diameter.

11.4.4 Cooling the Magnet to Liquid Helium Temperatures

For this procedure, the customer must provide the following:

- Six cylinders of helium gas: 50l/200 bar (~2 cu.ft, 3000 psi), 99.996%, with secondary regulator valve to deliver pressure of max 0.2 bar (~3 psi).
- Quantities of liquid helium as specified in the table found in the [Overview \[▶83\]](#).
- Liquid helium dewar: 250 - 500 liter capacity, with NW25 flange or suitable outlet compatible with the 12.7 mm (1/2").

When ordering the helium the customer should arrange to have it delivered immediately before cooling the magnet to liquid helium temperature. If delivered to the site much earlier, losses due to evaporation will occur and must be taken into account (usually 1% of nominal volume/day).

11.4.5 Charging the Magnet

The final stage involves bringing the magnet to field. This will take 1-3 days depending on the magnet type. During charging there is a possibility for the magnet to experience a quench.

The quantities of liquid helium for final cool down and energization/cryoshimming as well as extra liquid helium required after one quench are specified in the table below. The customer is required to provide the cryogens needed for the complete installation including up to two training quenches.

The values of liquid nitrogen and helium in the table below are the minimum requirements. An extra 20-30% of each is advisable, particularly as many suppliers will take back unused cryogen.

Magnet Type	Min. Ceiling Height (m)	Min. Hook Height (m)	Total Lifting Weight (kg)	LN2 Needed for Pre-cool (l)	LHe Needed for Cool-down and Charging (l)	LHe After a Training Quench (l)
Ascend 800	3.60	3.10	3,300*	2,500	2,500	750
Ascend 850	3.60	3.10	3,300*	2,500	2,500	750
850 WB US ²	5.30	4.75	6,700	6,000	5,000	1,500
900 US ²	5.30	4.75	6,700	6,000	5,000	1,500
900 WB US ²	5.30	4.75	6,700	6,000	5,000	1,500
950 US ²	5.30	4.75	6,700	6,000	5,000	1,500
WB= Wide Bore (89 mm); US ² = UltraShield-UltraStabilized						
* For Ascend 800 & Ascend 850 - This is the lifting weight uncrated with stand.						

Table 11.3: Installation Requirements for UltraStabilized Magnets

See also

 [Overview \[▶83\]](#)

Figures

Figure 2.1:	Stronger Stray Fields in Vertical Direction than in Horizontal Direction	9
Figure 3.1:	Spectrometer and Magnet Control	18
Figure 3.2:	CryoProbe System	19
Figure 3.3:	Other Options for AVANCE Systems	20
Figure 4.1:	Unloading the Magnet Crate and Placing on Air Skates	25
Figure 5.1:	Hydraulic Gantry for Lifting the Magnet Inside the Magnet Room	28
Figure 5.2:	Helium Transfer Line Insertion	29
Figure 6.1:	Magnetic Stray Field Plot Ascend 800	33
Figure 6.2:	Magnetic Stray Field Plot Ascend 850	34
Figure 6.3:	Magnetic Stray Field Plot 850 WB US2	35
Figure 6.4:	Magnetic Stray Field Plot 900 US2	36
Figure 6.5:	Magnetic Stray Field Plot 900 WB US2	37
Figure 6.6:	Magnetic Stray Field Plot 950 US2	38
Figure 8.1:	Main Electrical Power Requirements Flowchart	48
Figure 8.2:	Example of a Typical Dryer/Filter System Setup	51
Figure 9.1:	Magnet Dimensions	60
Figure 9.2:	Magnet Orientation	62
Figure 9.3:	Top View of an Ascend Magnet	63
Figure 9.4:	Ascend 800 and 850 NMR Layout Example	70
Figure 9.5:	AVANCE 950 US2 NMR Layout Example	71
Figure 10.1:	CryoProbe System Overview	74
Figure 10.2:	Helium Compressor - Indoor Water Cooled	76
Figure 10.3:	Helium Compressor - Indoor Air Cooled	76
Figure 10.4:	Helium Compressor - Outdoor Air Cooled	77

Tables

Table 1.1:	Metric to American Conversion Factors	8
Table 2.1:	BGV B11 Standards for Standard Precautions and Users.....	11
Table 2.2:	BGV B11 Standards Under Special Conditions for Selected Subgroups.....	11
Table 2.3:	Example of Maximum Retention Periods	12
Table 4.1:	Door Dimensions for Magnet Access	23
Table 4.2:	Magnet Transport Weights	23
Table 4.3:	Transport Weights of NMR Cabinets and Accessories.....	24
Table 5.1:	Minimum Ceiling Height Requirements and Lifting Weights Inside the Magnet Room.....	30
Table 6.1:	Horizontal Stray Fields (distances are measured in radial directions from magnet center)	31
Table 6.2:	Vertical Stray Fields (distances are measured in axial directions from magnet center)	32
Table 7.1:	Vibration Guidelines	39
Table 7.2:	Recommendations for Static Magnetic Objects	40
Table 7.3:	Guidelines for Moveable Magnetic Objects	41
Table 7.4:	Minimum Distances from Sources of DC EMF Interference.....	42
Table 7.5:	List of Most Commonly Studied Nuclei and Corresponding Resonance Frequencies	44
Table 8.1:	Pressure and Flow Requirements	50
Table 8.2:	Heat Generated by Typical AVANCE Systems	55
Table 8.3:	Helium Gas After a Quench.....	56
Table 9.1:	Dimensions and Weights of NMR Equipment	59
Table 9.2:	Magnet Dimensions and Total Weight	61
Table 9.3:	Recommended Magnet Slab Dimensions	63
Table 9.4:	Basic Design Requirements for Magnet Platforms	64
Table 9.5:	Maximum Field Strength for NMR Equipment	67
Table 9.6:	Utility Requirements	69
Table 10.1:	CryoCooling Unit Specifications	75
Table 10.2:	Technical Data for Indoor Compressors	77
Table 10.3:	Technical Data for Outdoor Compressors	78
Table 11.1:	Overview of Magnet Commissioning	83
Table 11.2:	Installation Requirements Checklist	84
Table 11.3:	Installation Requirements for UltraStabilized Magnets	86

Glossary

Air Skates

Air skates are fabricated load modules that are placed at strategic positions beneath a heavy load prior to moving the load. The air skates then provide support to the load while it is resting on top of them.

BMPC

Bruker Monitoring and Pump Control Unit

EAPD

Electronic Atmospheric Pressure Device

EDS

External Disturbance Suppression technology.

IconNMR

IconNMR is the data acquisition software available for AVANCE systems, that provides an easy-to-use software interface for common ^1H and ^{13}C experiments in a range of common NMR solvents.

Quench

A magnet quench is the breakdown of superconductivity in a partially or fully energized magnet. The stored field energy is transformed into heat, leading to a fast evaporation of liquid helium. During a quench, an extremely large quantity of helium gas (i.e. 43 m³ to 595 m³ depending on the magnet type) is produced within a short time. Although these gases are inert, if generated in large enough quantities, they can displace the oxygen in the room causing potential danger of suffocation. Although these gases are inert, if generated in large enough quantities, they can displace the oxygen in the room causing potential danger of suffocation.

SampleTrack

SampleTrack is a BRUKER laboratory automation and management system with a standardized interface for BRUKER spectrometers. As a software tool for the laboratory network, SampleTrack manages all automation process steps in an analytical environment.

TopSpin

TopSpin™ is our software package for acquisition, processing and analyzing NMR data, streamlined for your convenience. TopSpin was designed for Windows® and Linux® users with a highly intuitive interface utilizing the most widespread standards familiar from word processing, graphics, or presentation programs, providing the same look-and-feel for your NMR applications.

Index

A

Air compressor	18
Air conditioning	41
Airplanes	39
Air-skates	24
Automobiles	39
AVANCE Cabinet	
Dimensions and weight.....	59

B

B-CU-I	
Dimensions and weight.....	59
BCU-I cooling unit	49, 50
BCU-I Unit.....	18
BCU-II	
Dimensions and weight.....	59
BCU-II cooling unit	50
BCU-II Unit.....	18
BMPC	
Dimensions and weight.....	59
BMPC II.....	18, 18
Breathing equipment.....	16
BSNL.....	20
Buffer containers	51

C

Compressors.....	39
Constant flow rate	52
Construction sites	39
Crates	22
CryoCooling unit	47, 50
Cryogen	
Transport dewars	14
Cryogenic liquids.....	13
Storage containers	14
Cryogenics	
Boil-off of liquids.....	12
Cryogenic gas to liquid volume ratios	12
High pressure gas-packs	14
Safe handling of cryogenic liquids	13

D

D.C. operated elevators, trains	41
DC EMF	42
Dewars.....	68
Digital Lock	42, 43

E

EAPD	56
Earthquakes.....	15
EDS	42, 43
Electric motors	41
Electrical outlets.....	68
Electrical power requirements	47
Electrostatic Discharge	64
Elevators	14, 41
Emergency access	16
Emergency Plan	15
Emergency Sample Protection Device	50
ESD resistant flooring	64

F

Fans.....	39
Faraday cage.....	45
Ferromagnetic materials	40
Ferromagnetic objects	9, 10
Fiberglass	63
Fire extinguishers	16, 58
Floor Types	
PVC	64
Vinyl.....	64
Wood	64
Fluxgate magnetometer.....	42

G

Gas cylinder.....	14
Gas cylinder storage.....	68
Generators.....	39

H

Heat source	61
Helium fill port.....	61

Helium gas cylinder.....	19
Helium gas supply	
CryoCooling Unit.....	75
helium manifold.....	61
Homogeneity.....	40
Humidity.....	18
HVAC system.....	55
Hydraulic Lifting System.....	24

I

Isolated slab.....	63
--------------------	----

J

Joule-Thompson Cooling Unit.....	17
----------------------------------	----

L

Lifting hook.....	27
Liquid helium refill.....	14
Loose ferromagnetic objects.....	9

M

Machinery.....	39
Magnet cooling pump.....	47
Magnet maintenance.....	17
Magnet orientation.....	61
Magnet pits.....	66
Magnet platform.....	64
Magnet pump line.....	61
Magnet stand.....	61
Magnet temperature.....	17
Magnetic field.....	9
Exclusion zone.....	10
Magnetic field strength.....	11
Magnetic flux density.....	11
maximum point load.....	62
Medical implants.....	9, 10
MicroImaging Cabinet	
Dimensions and weight.....	59

N

Nitrogen	
Safe handling during refills.....	14
nitrogen separator.....	50

O

Oil Content:.....	50
Optical sensors.....	58
overall floor load.....	62
Oxygen level sensors.....	56
Oxygen-cylinders.....	16

P

Pacemakers.....	9
Power consumption	
CryoCooling Unit.....	75
Power lines.....	41
pre-action sprinkler system.....	58
Pressure relief valve.....	14
Pump line.....	17

Q

Quench	
He evaporation.....	56

R

Radio's.....	44
Refilling	
Safe handling of liquid nitrogen.....	14
RF environments.....	45
Rigging equipment.....	24
Lifting hook.....	27

S

Safety	
Exclusion zone.....	10
Ferromagnetic objects.....	10
Magnetic field.....	9
Medically active implants.....	10
Safe handling of cryogenic liquids.....	13
Safe handling of liquid nitrogen.....	14
Ventilation.....	12
Sample changers.....	67
SampleCase.....	20
SampleJet.....	20
SampleXpress.....	20
Satellite systems.....	44
Service access	

Magnet.....	68
Spectrometer	68
Solid Impurities	51
Stainless steel	63
Standard Operating Procedures	15
Subways	41
Sunlight.....	61
Support beams.....	61

T

Television broadcasts.....	44
temperature sensors	58
Trains	39
Trams	41
Transformers.....	41

U

UltraStabilized Magnets	17
UPS.....	47

V

Ventilation	
Emergency ventilation.....	13
HVAC systems	12
When using a magnet pit	66
Vibration	
Guidelines	39
Vibrations	39
Slabs.....	63
VT gas.....	18
VT work.....	50

W

Water Content:	50
Workstation	
Dimensions and weight.....	59



End of Document

 **Bruker Corporation**

info@bruker.com
www.bruker.com



AVANCE™ UltraStabilized™
PRE-INSTALLATION SITING REVIEW, Rev. 6.0, June 2011

CUSTOMER INFORMATION

Institution:

Users Name/Title:

E-mail

Phone

Name of person
filling out this form:

Date:

Magnet Type

- Ascend 800
- Ascend 850
- 850 WB US2
- 900 US2
- 900 WB US2
- 950 US2

Accessories

- MAS
- Solids
- BCU-I Cooling Unit
- BCU-II Cooling Unit
- Sample Changer
- CryoProbe
- Micro-Imaging
- Other _____

Expected Date of Delivery and Start of Installation:

NMR SYSTEM AND LARGE PACKAGES DELIVERY ADDRESS:

End Users Name:

Phone:

E-mail:

Facility manager:

Phone:

E-mail:

Receiving hours of operation:

FEDEX , UPS, MAIL – REGULAR PACKAGES DELIVERY ADDRESS

Receiving hours of operation:

1. ACCESS AND RIGGING

Delivery Area and Off-loading

- Is there sufficient space in the driveway or parking for the overhead crane and for the delivery flat-bed truck?
- Is there sufficient leveled area for uncrating the magnet crate?
- Distance of reach for the crane, estimated crane size needed:
- Is access to the NMR room being done with a crane through hatch in the roof?
- Is the NMR room at a different elevation relative to the delivery area? If yes, explain how the access to the NMR room is being done.
- Is access to the NMR room requiring air-skates?
- Any other considerations?

Continued on next page

ACCESS AND RIGGING, Continued

Access to the NMR Room

- Is there a suitable leveled slab (pad) in front of the access doors for positioning the magnet on air-skates? Is the slab capable to handle the size and weight of the magnet?

- Are masonite sheets needed to correct imperfections and protect flooring?

- Clearances along the access path from the delivery area to the NMR room

- Load bearing capacity along the access path

- Access of fork-truck or palette-jack

Rigging inside the lab for magnet lifting

- Fixed lifting hook in the ceiling/beam:
 - Hook height (floor to bottom of ceiling hook)
 - Max. lifting load
 - Height clearance from floor to hook of hoist system

 - Hydraulic lift system with I-beam
 - Height clearance for setting-up the hydraulic lift system:

 - Bruker special hydraulic lift system:
-

2. CEILING HEIGHT REQUIREMENTS

**Height for
lifting magnet**

- Ceiling height from the floor to underside of ceiling:

 - Ceiling hook height if applicable:

 - Footprint of ceiling above magnet with max. height clearance:
-

**Height for
magnet
energization**

- Final ceiling height above magnet measured from the floor:

 - Type of energizing rods (standard or bendable):
-

**Height above
He dewars**

- Ceiling height above He transport dewar measured from the floor:
-

**Obstructions
above and
below magnet**

3. FLOOR PLAN

Stray Fields

- Is the 5G line completely enclosed within the NMR room?
 - Is the magnet He cooling pump unit as well as the He compressor for the CryoProbe going to be located outside the 5G line?
-

Magnet Pit

- Footprint of the magnet pit:
 - Depth of the pit:
 - Reinforcement in the slab and walls of the pit:
-

Magnet Slab

- Is the magnet going to be placed on its own slab, isolated from the rest of the floor of the NMR room?
 - How is the isolation being done?
 - Size of the magnet slab:
 - Type of reinforcement used for the magnet slab:
 - Type of reinforcement is used for the main floor of the NMR room:
-

Magnet Platform

Platform around the magnet

- Material:
- Overall footprint of the magnet platform:
- Is the magnet platform going to be supported from the outside the magnet slab?
- Are the support posts going to interfere with the magnet, with the access to the magnet, or with the installation of the CryoProbe?
- Diameter of the circular opening:
- Height of the platform deck:
- Border around the opening:
- Removable section to allow for magnet access:

Rolling ladder (Ascend 800/850)

Continued on next page

3. FLOOR PLAN, Continued

Magnet Orientation

- Stairs of the platform
 - Magnet Manifold
 - He fill port, He supply dewars
 - Front of magnet stand, CryoProbe, Shims
-

Trenches

- Are there any trenches? If yes, please describe the scope and provide dimensions.
-

Magnet Pump Line – Route to the Pump Unit

- Route of magnet pump line
-

NMR Equipment

- UPS, BMPC
 - Avance cabinet, workstation
 - BSCU
-

CryoProbe Siting

- CryoCooling unit
 - Transfer lines from the CryoProbe to the CryoCooling unit
 - He compressor
 - Water chiller, and water quality
 - He gas and back-up air (or N2 gas) cylinders
-

Continued on next page

3. FLOOR PLAN, Continued

Floor plan
drawing

4. ENVIRONMENT AND SITE SURVEY MEASUREMENTS

Vibrations

- Vibrations measurements: on the magnet slab and outside the slab
 - Known sources of vibrations:
 - Mechanical equipment (HVAC, motors, pumps, etc.) operational (Yes/No):
 - Expected vertical accelerations on the magnet with the integrated isolators expected to be below the 0.1 mm/sec^2 threshold (Yes/No):
-

Magnetic Environment

- Is there any iron mass including reinforcement in the walls and floor that is present within an area of 3 meters radius from the magnet?
 - Are there any steel beams, columns radiators, plumbing pipes, metal tables, metal doors, filing cabinets, or other massive static steel objects within an area of 3 meters radius from the magnet?
 - Is there any moving iron mass present within an area of 6 meters radius from the magnet?
 - Are there any moving steel objects as large metal doors, hand trolley, or any large moving steel parts of machines and other mechanical equipment present within an area of 6 meters radius from the magnet?
 - Are there any elevators within 9 meters from the magnet?
 - Are there any trucks, cars, fork-lifts and alike being operated within 12 meters distance from the magnet?
 - Are there any trains passing within 30 meters distance from the magnet?
-

Continued on next page

4. ENVIRONMENT AND SITE SURVEY MEASUREMENTS, Continued

EMF Interference

- DC:
 - a) Are there any trains, subways, trams or associated DC power lines present within 100 meters distance from the magnet?
 - b) Are there any EPR instruments or mass spectrometers producing variable stray fields located into the same room or adjacent spaces?
 - DC EMF measurements with fluxgate magnetometer
 - AC: Are there any large transformers, AC power lines, or powerful lighting in close proximity to the magnet location?
 - AC 60Hz EMF measurements
 - RF:
 - a) Are there any TV/Radio Stations, Cellular Phone Towers, and Antennas, or other possible sources of RF in the building or within a radius of 5 kilometers?
 - b) Are there any other NMR or MRI systems operating at the same resonance frequency?
 - Details on possible RF sources
 - RF analysis
-

5. UTILITY REQUIREMENTS

Electrical Power, phone line commun.

- Main Power Disconnect Box - 208V/60A single phase:
 - Additional 208V single phase NEMA L6-30R (1), L6-20R (2):
 - Conduit powering the Avance from the BMPC II:
 - Conduit powering the CryoCooling unit:
 - 110V outlets:
 - Power for the He compressor, disconnect box - 208V/60A fused, 3-phase:
 - Power for BSCU or BSCU-X - 208V/20A, 1-Ph:
 - Power for the workstation. Is house UPS available for this?
 - Back-up emergency generator (Yes/No). What is being covered by it?
 - Fax / modem dedicated line:
-

Compressed gas

- Air:
 - Nitrogen:
 - Pressure:
 - Flow:
 - N2 separator:
-

Water

- Chiller and quality specs for water (CryoProbe with indoor water-cooled He compressor):
-

Continued on next page

5. UTILITY REQUIREMENTS, Continued

Lighting

- Types of lights:
 - Are all lights at least 3 meters away from the magnet center?
 - Are there any spot lights on the magnet?
-

HVAC

- Is there an HVAC system dedicated to the NMR room?
 - Is the air flow into the NMR room continuous?
 - How is the air temperature control being done? Are there any control switches operating the HVAC that may cause oscillations in flow/temperature:
 - Is the HVAC exchanging a large air-volume and are there any air drafts inside the NMR room associated to it?
 - Is there noticeable noise (acoustical vibrations) produced by the HVAC system?
 - Is there ductwork present in the room or adjacent space, what is the material that is made out of, and does it show signs of vibrations?
 - Location of air supply diffusers and return (exhaust) grills:
 - Is there any air draft towards magnet or console?
 - Are there any windows in the NMR room and any direct sunlight in the space?
 - What is expected temperature stability inside the NMR room, in the area of the magnet and console?
-

Continued on next page

5. UTILITY REQUIREMENTS, Continued

Emergency Gas Exhaust, and misc. utilities

- Space volume available in the NMR room (approx.):
 - Volume of He gas after a quench:
 - Calculated height of He gas cloud (measured from the floor) after a quench:
 - Type of emergency exhaust:
 - Passive (louver):
 - Active (fan) and activation:
 - Quench pipe:
 - Ventilation required during the installation (cooling of magnet) and follow-up cryogen fills:
 - Make-up air for emergencies:
 - Location of smoke detectors:
 - Location and type of sprinkler heads:
 - O2 sensors - in the upper part as well as lower part of the room?
 - Location
 - Automatic switch-on of the emergency exhaust
 - Heat sensors wired-in to the O2 sensors
 - Manual override button for emergency exhaust / conditions:
-

Cryogenics

- Cryogenics needed for the installation:
 - Liquid cryogenics: LN2 and LHe
 - Gases
 - What is the access path for cryogen supply dewars, and are all openings large enough for these dewars. Does the access path for cryogen dewars intrude into the 5G areas of adjacent magnets?
 - High purity He gas for the CryoProbe:
 - Back-up N2 gas or air for the CryoProbe:
-

6. DECLARATION BY THE INSTALLATION CONTACT

**Declaration by
the Installation
Contact**

I acknowledge receipt of the Bruker BioSpin document entitled “General Safety Considerations for the Operation and Installation of Superconducting Magnets”.

I confirm that, to the best of my knowledge and belief, the information that I have given in sections 1 – 5 of this Site Planning Checklist is accurate.

For safety reasons I agree that the Bruker BioSpin installation engineer will not be allowed to work alone at any time, and his work will be suspended if left unaccompanied.

I understand that after the magnet has been installed, for safety reasons, routine maintenance tasks involving transfer of cryogenic liquids must be performed by personnel formally trained to do so.

Signature of Installation Contact:

Name of Installation Contact:

Date:

7. DECLARATION BY THE SAFETY OFFICER

Safety Officer

Your Site Safety Officer must complete this section.

Magnet Lab Safety Officer's name

Magnet Lab Safety Officer's telephone number

Magnet Lab Safety Officer's e-mail address

Safety Hazards: Please describe any existing hazards present on your site that our Installation Engineer should be aware of e.g. chemicals/acids, laser equipment, radioactive sources, other magnetic devices, etc.

.....
.....*please continue on separate sheets if necessary*

Induction Training: If you feel that our Installation Engineer will require Induction Training to prepare him for the hazards on your site, please indicate the type and duration of such training:

.....

Cryogen Storage: Is there a facility for the safe storage of cryogens and gas cylinders on your site?

Yes If no, briefly explain.....

No

Cryogen Transportation: What arrangements do you have to safely transport cryogen dewars from the delivery point to their final point of use?

.....
.....

Note: Users are reminded that personnel must never accompany cryogen dewars in elevators.

O2 Monitor: Will an oxygen level monitoring device be available at the magnet's location?

Yes If no, briefly explain.....

No

Lifting Equipment: Are records/certificates available to confirm that the lifting equipment to be used to move and assemble the magnet is in sound condition and subject to regular examinations?

Yes If no, briefly explain.....

No

Continued on next page

7. DECLARATION BY THE SAFETY OFFICER, Continued

**Declaration by
the Safety
Officer**

I acknowledge receipt of the Bruker BioSpin document entitled “General Safety Considerations for the Operation and Installation of Superconducting Magnets”.

I confirm that, to the best of my knowledge and belief, the safety information that I have given in this section 7 of the Site Planning Checklist is accurate.

For safety reasons I agree that the Bruker BioSpin installation engineer will not be allowed to work alone at any time, and his work will be suspended if left unaccompanied.

I understand that after the magnet has been installed, for safety reasons, routine maintenance tasks involving transfer of cryogenic liquids must be performed by personnel formally trained to do so.

Signature of Site Safety Officer:

Date:

Name of Site Safety Officer:

Telephone:

Fax:

E-mail:
