



EPR 12T • Cryogen Free

User Manual

Version 00



Copyright © by Bruker Corporation

All rights reserved. No part of this publication may be reproduced, stored in a retrieval system, or transmitted, in any form, or by any means without the prior consent of the publisher. Product names used are trademarks or registered trademarks of their respective holders.

This manual was written by

Renate Petry

© April 13, 2011: Bruker Corporation

Faellanden, Switzerland

ZTKS0213 / Z31939 / Rev.: 00

For further technical assistance on the EPR 12T Cryogen Free magnet system, please do not hesitate to contact your nearest BRUKER dealer or contact us directly at:

BRUKER BioSpin GmbH
Silberstreifen 4
D-76287 Rheinstetten
Germany

Phone: + 49 721 5161 0
FAX: + 49 721 5171 01
E-mail: epr@bruker-biospin.de
Internet: www.bruker.com

0	Contact	5
1	Introduction.....	7
1.1	General Information.....	7
1.2	Limitation of Liability	7
1.3	Warranty.....	7
1.4	Copyright.....	7
1.5	Customer Service.....	8
1.6	General View.....	8
2	Safety.....	9
2.1	Approved Persons.....	9
2.2	Customer Responsibilities.....	10
2.3	Key Words and Symbols.....	11
2.4	Persons.....	12
2.5	Intended Use.....	12
2.6	Residual Risks.....	13
2.7	Signs and Labels.....	17
2.8	Safety Devices.....	19
2.9	Behavior During Dangerous and Emergency Situations.....	20
2.10	Fire Department Notification.....	20
3	Transportation	21
3.1	Safety.....	21
3.2	Packaging.....	22
3.3	Transportation Inspection.....	22
3.4	Transportation by Forklift / Pallet Jack.....	23
3.5	Storage.....	24
4	Assembling	25
4.1	Safety.....	25
5	Operation.....	27
5.1	Safety.....	27
5.2	Evacuating the Cryostat.....	28
5.2.1	General View.....	28
5.2.2	Mounting the Vacuum Valve at the Evacuated Cryostat.....	29
5.2.3	Rebuilding Vacuum.....	30
5.2.4	Removing the Vacuum Valve.....	31
5.3	Bruker Cryogen Free Controller (BCFC).....	32
5.4	Power Supply.....	35
5.4.1	Description.....	35

5.4.2	First Steps	36
5.5	Cooling Down	38
5.6	Operation of the BCFC	39
5.6.1	Compressor Status Check	39
5.6.2	Emergency Button Test	40
5.6.3	Energizing the Magnet	41
5.6.4	Emergency Quench	42
5.6.5	Warming up the Magnet	43
5.7	Power Supply Operation	44
5.7.1	Selecting the Operation Mode	44
5.7.2	Energizing and Deenergizing in Main Mode	44
5.7.3	Energizing and Deenergizing in Sweep Mode	46
6	Troubleshooting	47
6.1	Safety	47
6.2	Problems	48
6.3	Solutions	49
7	Maintenance	51
8	Disassembling	53
8.1	Safety	53
A	Appendix	55
A.1	Warning Signs	55
A.2	Figures	57
A.3	Tables	59
A.4	Glossary / Abbreviations	61
A.5	Technical Data	63
A.5.1	Components	63
A.5.2	Dimensions	63
A.5.3	Cryostat Dimensions	64
A.5.4	Specifications	66
A.5.5	Power Supply Parameters	68
A.5.6	Base Temperature Report (Monthly)	71
A.5.7	Other Applicable Documentation	73
A.6	Index	75

0 Contact

Manufacturer

Bruker BioSpin GmbH

Silberstreifen 4

D-76287 Rheinstetten

Germany

Phone: +49 721 5161 0

Fax: 49 721 5171 01

Email: epr@bruker-biospin.de

<http://www.bruker.com>

Please refer to the model no., serial no. and internal order no. in all correspondence regarding the EPR magnet system or components thereof.

1 Introduction

1.1 General Information

This manual contains important information about the handling of the magnet system. The compliance with all safety and handling instructions and the applicable local accident prevention and general safety regulations is necessary for safe work.

This manual is part of the product. It must be kept in the vicinity of the magnet system and unimpeded access must be ensured at any time.

Read this manual carefully before operating the magnet system.

1.2 Limitation of Liability

The information in this manual will take into account the current state of technology.

The manufacturer assumes no liability for damages resulting from:

- non-compliance with the instructions and all applicable documentation,
- use for purposes not intended,
- not sufficiently approved persons,
- arbitrary changes or modifications and
- use of unauthorized spare parts or accessories.

1.3 Warranty

The warranty terms can be found in the sales documents of the magnet system and in the Terms and Conditions.

1.4 Copyright

No part of this publication may be reproduced, stored in a retrieval system, or transmitted in any form, or by any means without the prior consent of the publisher. Product names used are trademarks or registered trademarks of their respective holders.

1.5 Customer Service

Technical support is provided by our customer service via telephone or e-mail. For contact information see [page 5](#) of this document.

1.6 General View

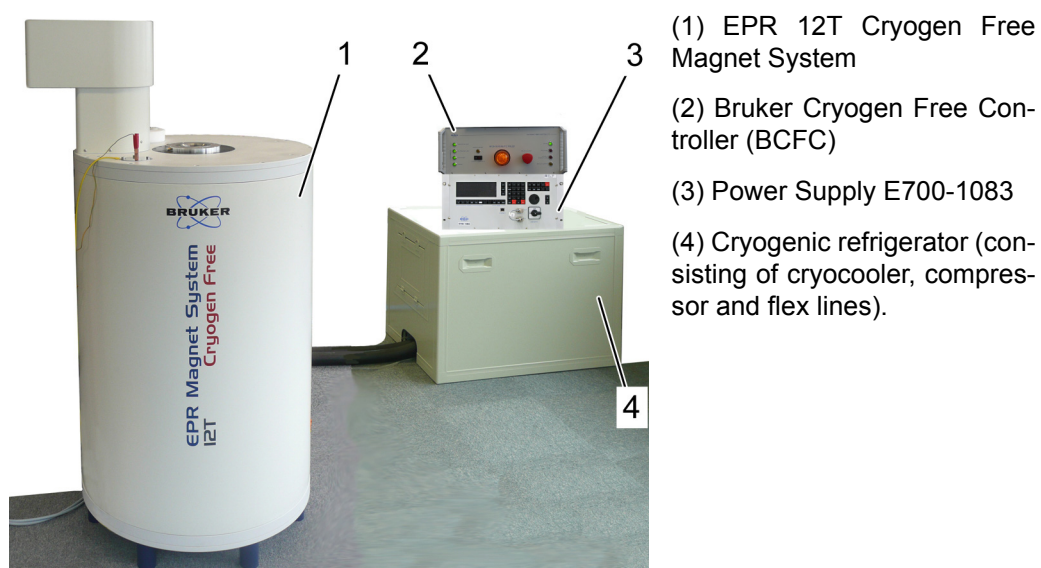

Figure 1.1: Overview of the EPR magnet system

2 Safety

The supplied cryostat of the magnet system was designed and manufactured according best available technical knowledge and practice, archived in over 50 years of experience of Bruker Corporation. International standards for quality and approval recommended for cryostats of superconducting magnets were certified.

Nevertheless non-compliance with the following instructions and safety advice may cause serious hazards and property damage.

2.1 Approved Persons

Bruker BioSpin AG identifies the following qualifications for personnel performing tasks on the magnet system or its components:

Approved Customer Personnel

As a result of professional training by Bruker Service Personnel, experience and knowledge of applicable regulations these persons are qualified to perform the specific tasks on the magnet system and its components assigned to them in this manual. Approved Customer Personnel are qualified to identify possible hazards and risks associated with the tasks assigned to them and to perform all possible steps to eliminate or minimize these risks.

Bruker Service Personnel

These persons are qualified by appropriate qualification and professional training and experience (including all necessary knowledge of applicable regulations and regulatory requirements) to perform specific tasks on the magnet system and its components. Bruker Service Personnel are qualified to identify possible hazards and risks and to perform all possible steps to eliminate or minimize these risks.

2.2 Customer Responsibilities

The customer must obey the security advice and the rules for safety, accident prevention and environmental protection valid for magnet systems. Furthermore, the customer is responsible for keeping the magnet system in correct technical condition.

In particular:

- The customer must identify additional dangers resulting from the working conditions at the site of the magnet system and implement applicable safety measures.
- The customer must ensure that the site plan meets the specified conditions for operating the magnet system.
- The customer must clearly mark the danger area around the magnet system and install the corresponding instruction plates.
- The customer has to inform the local fire brigade about the special risks of the magnet system.
- The customer must clearly define the responsibilities for operation and maintenance.
- The customer must ensure that all employees working with the magnet system have read and understood the manual.
- The customer has to consider the specific conditions of operation of this cryogen free cryostat equipped with a cryogenic refrigerator. The customer is responsible for obeying the advice given in this manual. In case the cryogenic refrigerator is not running correctly he must immediately react following the advice given in this manual.
- The customer has to instruct his employees at regular intervals on hazards and safety measures.
- The customer has to instruct other persons not working on the magnet system but carrying out work in the same room, for instance cleaning staff.
- The customer must ensure that maintenance is performed according to the schedule listed in section ["Maintenance" on page 51](#).

2.3 Key Words and Symbols

The safety alert symbols indicate a potential personal injury or property damage hazard. The key word at the beginning of the security advice informs about the extent and nature of the threat.

Safety advice must be adhered to in order to prevent dangerous situations for persons and property.

Personal injury



DANGER

Indicates a hazardous situation which, if not prevented, will result in death or serious injury.



WARNING

Indicates a hazardous situation which, if not prevented, could result in death or serious injury.



CAUTION

Indicates a hazardous situation which, if not prevented, may result in moderate or minor injury.

Property damage

NOTICE

Hazard, which could result in property damage.

Information and tips



Information and tips for efficient and trouble-free operation.

2.4 Persons



WARNING

Risk of injury and property damage due to handling by not approved persons.

Incorrect handling of the magnet system by not approved persons may result in significant bodily injury and property damage.

Thus:

- Work must only be carried out by approved persons with applicable qualifications. The necessary qualifications are specified at the beginning of the relevant chapters.
- In case of doubt contact Bruker Service. Contact information see [page 5](#) of this document.

2.5 Intended Use

The magnet system is exclusively designed and constructed for a magnet field of up to 12.0 T for EPR measurements.



WARNING

Risk of damage to life and limb by incorrect use of the magnet system.

Incorrect use of the magnet system can lead to life-threatening situations and destruction of the magnet system.

Thus:

- Only use the magnet system as intended.
- Do not change the magnet system.
- Do not exceed specified values for the movement and for the operation of the magnet system.
- It is prohibited to energize the magnet above 12 T.

Damage claims from damages caused by other than the intended use of the magnet system are excluded and the customer is held liable.

2.6 Residual Risks

In the following section, the residual risks from the risk analysis are summarized.

To prevent health hazards and hazardous situations obey all safety instructions and warnings in the manual.

Electricity

WARNING



Risk of damage to life and limb due to electricity.

Risk of damage to life and limb due to contact with electrical lines and damaged insulation.

Thus:

- Work on electrical equipment must be done by an approved electrical technician.
- Keep moisture away from electrical lines to prevent short-circuits.
- Check the magnet system accidental ground before start up.

Magnetic Field

WARNING



Risk of damage to life and limb due to high magnetic fields.

A magnetic field of more than 0.5 mT (5 Gauss) is life-threatening for people with pacemakers or metal implants. Ferromagnetic tools in the magnetic field are significantly hazardous. Disks and electronic devices may be damaged. Duration of exposure (8 h/day) above the limit of 200 mT can cause damage to health.

Thus:

- Do not use ferromagnetic tools or items within the identified area.
- Mark the magnetic field of more than 0.5 mT (5 Gauss) before start up.
- The workplace must be outside the 0.5 mT area.
- Only use safety shoes with non-ferromagnetic toe caps.
- Keep people with pacemakers and metal implants away from the identified area.
- Keep disks, credit cards and electronic devices away from the identified area.
- Only use transport dewars of non-ferromagnetic material for the cryogenic agents.
- Only use non-ferromagnetic ladders or steps.

Assembly/Disassembly

CAUTION



Risk of injury and property damage due to incorrect assembly/disassembly of the cryogenic refrigerator.

Assembly/disassembly requires approved persons with sufficient experience. Mistakes during assembly/disassembly of the cryogenic refrigerator may result in property damage.

Thus:

- Flexible gas lines (supply and return) must be connected/disconnected only when the magnet system is warmed up.
- Inspect the flexible gas lines and pay regard to visible damage.
- Respect detailed instructions on assembling/disassembling given in the manual of the cryogenic refrigerator.

Inserting and Removing the VTI

WARNING



Risk of damage to live and limb during inserting and removing the VTI and/or the sample holder.

Metallic items in close vicinity of the magnet system get attracted from strong magnetic forces during a magnet quench.

Thus:

- Insert or remove the VTI and/or the sample holder only at zero field.
- Only use VTIs and/or sample holders approved by Bruker Service.

Risk of Tilting

WARNING



Risk of injury due to tilting of the magnet system.

The magnet is sensitive to lateral forces. It may tilt.

Thus:

- Do not climb onto the magnet system.
- Do not lean items against the magnet system.
- Do not lean against the magnet system.
- Do not move the magnet system on your own.

Heavy Weights

WARNING



Risk of damage to life and limb caused from moving heavy weights.

Lifting heavy weights is life-threatening due to falling or moving parts.

Thus:

- Do not stay or work under lifted boxes.
- All used lifting equipment must be approved to carry the weight (see Technical Data on [page 63](#)).
- Do not use damaged lifting equipment.
- Do not use lifting equipment without updated check tag.
- Lifting only with approved qualification.
- Obey ergonomic guidelines while lifting heavy parts.
- Protect parts against falling.

Transportation

CAUTION

Risk of injury and property damage due to incorrect transportation.

The box may tilt, movement may get out of control. Thus persons may get injured and the cryostat or further equipment may be damaged.

Thus:

- Be careful while unloading and moving the boxes.
- Do not move the boxes arbitrarily.
- Pay attention to all symbols on the boxes.
- Pay attention to sharp edges and spikes of boxes and parts by using protective gloves while moving.
- Move the boxes in an upright position.
- Do not tilt the boxes.
- Prevent crossing thresholds, even if they are only a few millimeters high.
- Clean the transportation way before moving the boxes.
- Unpack shortly before assembling.
- The cryostat or further equipment must be protected from rain and other bad weather conditions during transportation.
- Exclusively move the cryostat in its original box.
- Do not remove the tightening straps inside the box until assembling.
- Only use the provided attachment points.
- Ensure that the cryostat is always carefully leveled, even if it is hanging on the crane.
- Do not move the evacuated cryostat.
- Do not move the cryostat after cool down.



2.7 Signs and Labels

WARNING



Risk of damage to persons and property due to not readable signs and labels.

Signs and labels with advice may become not readable.

Thus:

- Maintain labels and signs in a readable state.
- Replace damaged or not readable signs and labels immediately. New signs and labels can be obtained from Bruker Service.

Signs and labels are always related to their immediate vicinity. The following signs and labels are found on the magnet system and in the vicinity:



Prohibition sign: No person with pacemakers!

People with pacemakers are endangered in the identified area of 0.5 mT (5 Gauss) and are not allowed to enter these areas.



Prohibition sign: No person with implants!

People with metallic implants are endangered in the identified area of 0.5 mT (5 Gauss) and are not allowed to enter these areas.



Prohibition sign: No watches or electronic devices!

Watches and electronic devices may be damaged in the identified area of 0.5 mT (5 Gauss).



Prohibition sign: No credit cards or other magnetic memory!

Credit cards and magnetic memory may be damaged in the identified area of 0.5 mT (5 Gauss).



Prohibition sign: Do not touch! Do not block!

Do not touch or block the identified area.



Hazard warning sign: Strong magnetic field!

- No magnetic storage devices.
- No jewelry.
- No metallic items.



Emergency exit!

- Always keep the emergency exit clear.
- Follow the arrows if necessary.
- Emergency exit doors must open in direction of escape.

2.8 Safety Devices

WARNING



Risk of damage to life and limb due to not sufficient safety devices.

Several safety devices and safety valves ensure safe operation. They must always be in correct working condition.

Thus:

- Do not block safety devices.
- Check the operational reliability of the safety devices before working on the magnet system.
- Do not remove safety devices from the magnet system.
- Do not disconnect the power supply or the thyristor during operation of the magnet system.

i For more information about the safety devices of the cryogenic refrigerator refer to the supplied manual.

Emergency Quench

In case of emergency it may be necessary to quench the magnet and to stop the hazardous magnetic fringe field. The quench can be executed via an emergency button ("Magnet Quench") on the front panel of the BCFC. For detailed information see "[Emergency Quench and Status Indicators](#)" on page 33.

Drop-off Plate

A drop-off plate is a safety device of the room temperature vessel. If the vacuum breaks, the drop-off plate will open. In case of an accidental overpressure in the vessel the drop-off plate will release the pressure smoothly.

Power Supply

The security of the system and of the operator depend on safety devices integrated in the power supply which must be kept connected to the magnet system.

2.9 Behavior During Dangerous and Emergency Situations

Preparations

- Keep the emergency exits free at any time.
- Prepare and maintain an up-to-date list of emergency telephone numbers in the magnet system area.

In Case of Emergency

- Leave the danger zone immediately.
- Rescue persons from the danger zone.
- Start first aid immediately.
- Call the responsible contact.
- Call for medical assistance.
- Call the fire department.

2.10 Fire Department Notification

- Inform the fire department about the potential risks of a magnet system, i.e. danger of ferromagnetic rescue equipment close to the magnet system.
- Laboratory windows which are accessible during an emergency should be clearly identified with warning signs, visible from the outside.

3 Transportation

i The transportation is carried out by Bruker Service or by approved persons. However, it may happen that not approved persons have to take the delivery of the transport boxes. In this case the customer has to inform these persons about requirements for transportation given in this chapter. In case of doubt contact Bruker Service.

3.1 Safety



WARNING

Heavy Weights (see [page 15](#))

Risk of Tilting (see [page 15](#))



CAUTION

Incorrect Transportation (see [page 16](#))

3.2 Packaging

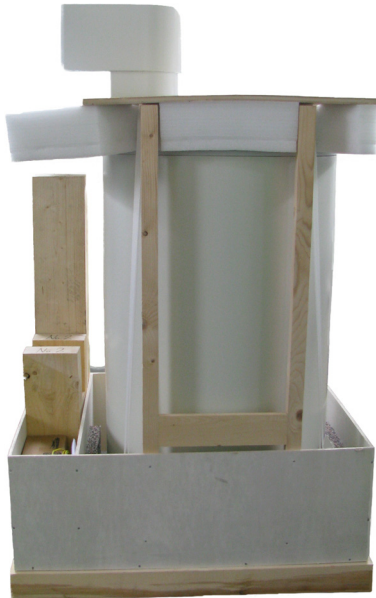

Figure 3.1: Packaging

The magnet system is packed in a transport box. It is secured inside with tightening straps against tilting and moving.

Accessories such as cryogenic refrigerator parts and flex lines are packed in separate transport boxes.

For handling of the cryogenic refrigerator parts refer to the supplied manuals (see ["Further Applicable Documentation" on page 73](#)).

3.3 Transportation Inspection

Investigate the delivery with regard to visible damage and completeness of packaging.

The shipping and handling monitors on the transport box show whether the transport box were kicked or tilted during transportation.

Checks

1. Shock Watch: Follow the instructions on the label.
2. Tilt Watch: Follow the instructions on the label.
3. Investigate the transport box and the magnet system concerning visible damage and completeness.

In case of damage

- Accept the delivery with reservation.
- Make a note of the extent of damage in the transportation documents.
- Start the complaint process.
- Contact the manufacturer before installation.

i The claim for damage expires after the fixed period.

Thus:

Report damages to Bruker Service immediately after detection. For contact information see [page 5](#) of this document.

3.4 Transportation by Forklift / Pallet Jack

Persons in charge

- Approved forklift / pallet jack operator

Precondition

- The forklift / pallet jack must be approved for the transportation weight (see [“Weights” on page 63](#)).

NOTICE

Property damage caused by vibrations during transportation!

The crossing of thresholds with a forklift or a pallet jack may damage or destroy the magnet system.

Thus:

- Prevent crossing thresholds, even if they are a few millimeters only.
- Do not tilt the forklift or the pallet jack during the transportation of the magnet system.
- Make sure the magnet system is carefully leveled during transportation.

Transport

1. Check the route of transport for the minimum height and width.
2. Check sufficient floor capacity on the route of transport. In case of doubt ask a stress analyst.
3. Check sufficient carrying capacity while using an elevator.
4. Position the forks between the bars of the transport box as shown in the figure.
5. Make sure the forks project out of the back of the transport box as shown in the figure below.



6. Now lift the fork and move the transport box to the site.

Figure 3.2: Transportation by forklift / pallet jack

3.5 Storage

If it is necessary to store the magnet system before installation comply with the following conditions:

- Store the transport box in a closed, dry and dust-free room.
- Store the transport box upright.
- Do not tilt the transport box.
- Do not unpack the transport box.
- Prevent from mechanical vibrations.
- Storage temperature: 5 – 40 °C.
- Storage humidity: less than 50 % @ 23 °C.

4 Assembling

4.1 Safety

Persons in charge: Bruker Service only.

5 Operation

5.1 Safety

WARNING



Magnetic Fields (see [page 13](#))

Electricity, High Voltage (see [page 13](#))

Safety Devices (see [page 19](#))

5.2 Evacuating the Cryostat

5.2.1 General View

The vacuum valve (Material No. Z53420) is necessary to evacuate the vacuum chamber of the cryostat after assembling the magnet system.

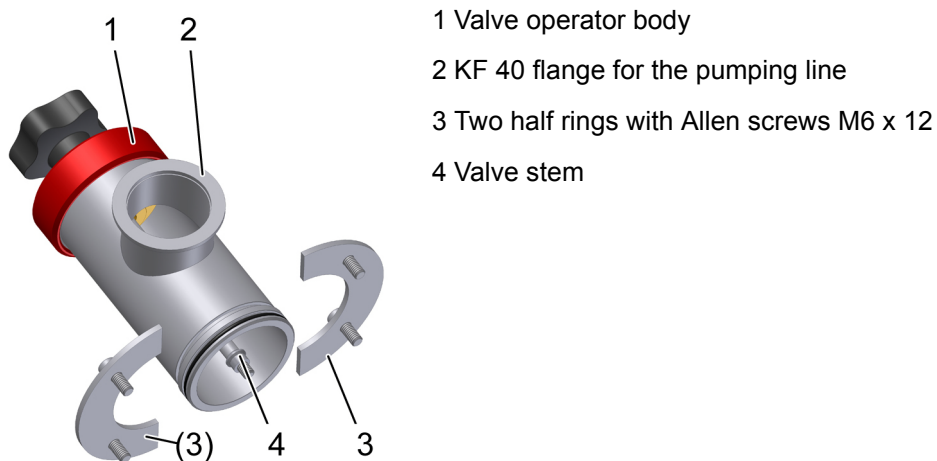

Figure 5.1: Vacuum valve assembly

i Tilting of the vacuum valve damages the O-ring of the vacuum valve. Thus, pay attention to the orientation of the axis during insertion of the vacuum valve.

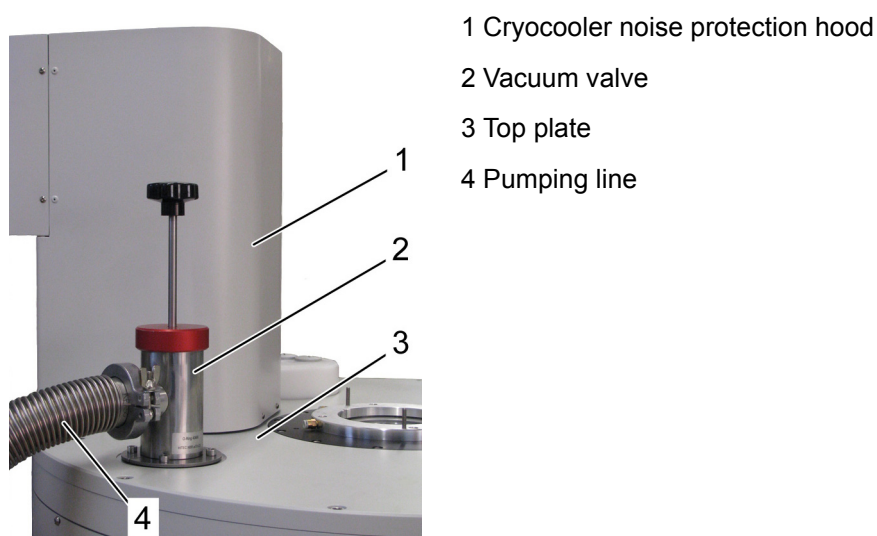

Figure 5.2: Vacuum valve mounted on the magnet system

5.2.2 Mounting the Vacuum Valve at the Evacuated Cryostat

Precondition

- Magnet system deenergized.
- Magnet system at 300 K.

Procedure

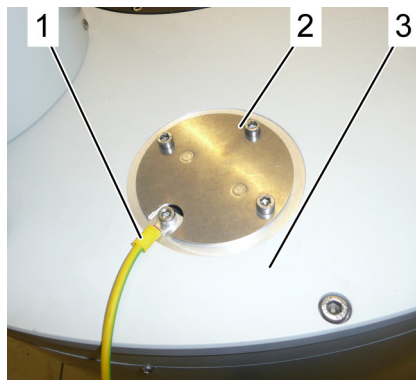

Figure 5.3: Removing the earthing cable

1. Remove the earthing cable (1).
2. Remove the protective cap (2) from the top plate (3).

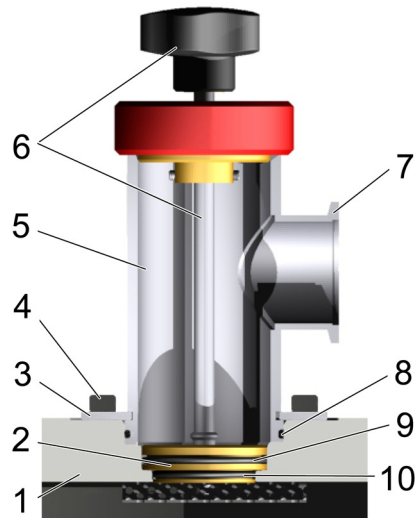

Figure 5.4: Mounting the vacuum valve at the evacuated cryostat

3. Install the valve stem (6) onto the sealing plug (2) and tighten it slightly. Do not yet fix the valve operator body (5) to the cryostat.

NOTICE:

The sealing plug can not be moved until a correct vacuum was applied at the KF 40 flange of the vacuum valve.

4. Turn the vacuum valve in the desired position. The KF 40 flange should be looking outwards allowing an easy connection of the pumping line.
5. Place the two half rings (3).
6. Fix the half rings (3) using four Allen screws M6 x 12 (4).

5.2.3 Rebuilding Vacuum

Precondition

- Vacuum valve mounted.

Procedure

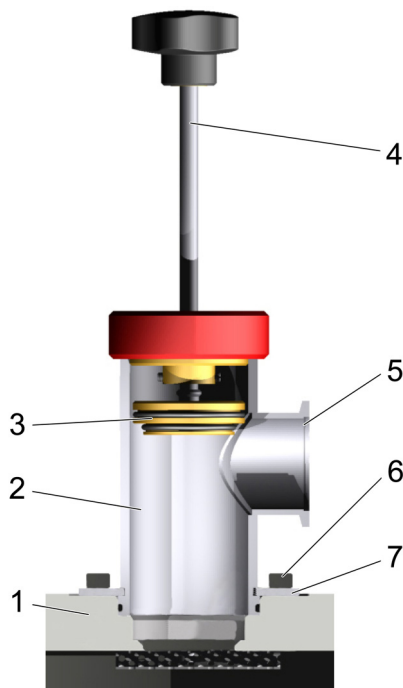
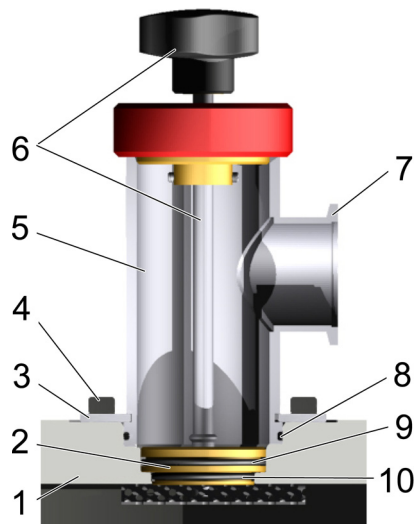

Figure 5.5: Rebuilding vacuum

1. Use the KF connector to connect the vacuum pumping unit with the KF 40 flange (5) of the vacuum valve (2). Use a short pumping line with a large diameter.
2. Evacuate the vacuum valve and the pumping line to a pressure of better than 5×10^{-5} mbar.
3. Pull out the valve stem (4) of the valve body to release the sealing plug out of the top plate (1). The sealing plug (3) snaps into place. The snapping is well defined and will be heard and felt. The cryostat is open after this procedure.
4. Continue generating a vacuum of better than 5×10^{-5} mbar (up to 2 –3 hours).
5. Push the valve stem (4) slightly into the valve operator body (2) to insert the sealing plug (3) into its seat in the top plate (1). The sealing plug snaps in. The snapping is well defined and will be heard and felt.
6. Stop pumping.
7. Vent the pumping line.
8. Disconnect the turbomolecular pump.
9. Remove the vacuum valve (see [“Removing the Vacuum Valve”](#) on page 31).

5.2.4 Removing the Vacuum Valve



1. Vent the pumping line.
2. Remove the pumping line at the KF 40 flange (7).
3. Release the valve stem (6) from the sealing plug (2) and pull out the valve stem.
4. Remove the four M6 x 12 screws (4) from the half rings (3).
5. Remove the half rings (3) and remove the vacuum valve.

Figure 5.6: Removing the vacuum valve

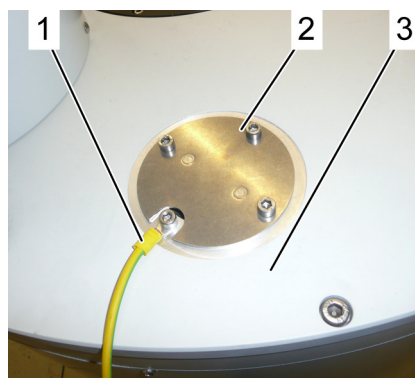

6. Mount the protective cap on the top plate.
7. Mount the earthing cable.

Figure 5.7: Mounting the earthing cable

5.3 Bruker Cryogen Free Controller (BCFC)

The functionality of the Bruker Cryogen Free Controller (BCFC) is described from the left to the right on the front panel (see [Figure 5.8](#)).

1. Remote compressor status display.
2. Warming up the magnet system.
3. Indication of presence of high magnetic field (fringe field).
4. Emergency quench and status indicators.



Figure 5.8: Bruker Cryogen Free Controller (BCFC) – Front View

Remote Compressor Status Display

Four green LEDs are placed on the front panel of the BCFC to display the compressor status. The detailed description of their functionality can be found in the compressor manual. To operate the magnet system it is necessary to have all four green indicators active (ON). If any of them is inactive (OFF), refer to the compressor manual for information.

Warming-up functionality

For service of the cryocooler it is necessary to have the magnet system at room temperature. To warm up the magnet system, a warm up heater is located on the magnet within the system, which is connected to a power source in the BCFC through the warm up switch ("WARM UP MAGNET"). A yellow indicator ("MAGNET IS WARMING UP") shows the heater is active (heating).

To activate the heater the following conditions have to be met:

1. The magnet system must be deenergized. If the magnet is energized, the heater cannot be activated, and the indicator remains inactive (“OFF”).
2. The magnet must be below ambient temperature (300 K). While the magnet is at ambient temperature the heater and the indicator remain inactive. This is a protection against overheating the magnet. It will also make sure that the heater is switched off as soon as the magnet reaches ambient temperature (after 1 – 2 days).

Magnetic Field Indicator

The magnetic field indicator shows whenever the magnet is energized and hazardous fringe fields occur around the magnet.

The indicator can be placed on top or on the front panel of the BCFC. Make sure that the indicator is clearly visible from all locations within the 5 G contour (see [Table A.7](#) and [Figure A.3 on page 66](#)).

There is a connector for an additional indicator on the rear panel of the BCFC in case an external indicator needs to be installed for enhanced visibility.

Emergency Quench and Status Indicators

In case of emergency (e.g. fire), it may be necessary to quench the magnet intentionally and to eliminate the hazardous magnetic fringe field. The quench can be executed via an emergency button (“Magnet Quench”) on the front panel of the BCFC.

For remote control of the “Magnet Quench” option the BCFC is equipped with a connector at the rear panel (see [Figure 5.9](#)).

Activating the “Magnet Quench” will lead to the following actions on the magnet system:

- The compressor will be stopped immediately.
- A heater is activated in the magnet system which rapidly increases the magnet temperature. Raising the magnet’s temperature will lead to a quench of the magnet.

i The heater is backed by an internal UPS in the BCFC, so the “Magnet Quench” functionality is available even during power failure (see also section [“Emergency Quench” on page 42](#)).



Figure 5.9: Bruker Cryogen Free Controller (BCFC) – Rear View

- The green indicator (1, “ARMED”) is active while the “MAGNET QUENCH” button is in stand by mode. It should always be active (“ON”), otherwise the magnet quench safety functionality is not available.
- The red indicator (2, “TRIGGERED”) is active when the “MAGNET QUENCH” button has been pushed and the magnet is going to quench.
- The red indicator (3, “AC INPUT POWER FAILURE”) displays whether AC power is supplied to the BCFC. As it has an internal UPS, it will keep on working for some residual time. After this time, the BCFC is completely inactive! Restore AC power quickly!
- The yellow indicator (4, “REPLACE BATTERY”) lights up if the battery of the UPS needs to be replaced (every 4 – 5 years).

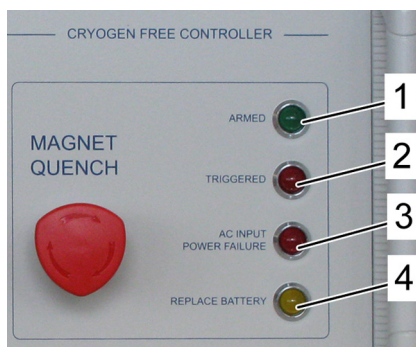

Figure 5.10: Magnet quench indicators on the BCFC front panel

NOTICE

Use the “MAGNET QUENCH” button only in case of emergency. It is a safety element that is optimized for quick reaction time. The magnet system may get damaged from this action.

5.4 Power Supply

5.4.1 Description

The EPR 12T CF magnet has a main coil and a sweep coil. The main coil produces a homogeneous field of up to 12 T. The main coil has a persistent switch which allows a very high field stability of the magnetic field. The sweep coil generates a homogeneous magnetic field of $\sim \pm 0.12$ T on top of the background magnetic field of the main coil, with a very high resolution. The sweep coil does not have a persistent switch.

Energizing and deenergizing the magnet always generates heat in the coils due to hysteretic losses in the superconductor, with the heating power proportional to the charging rate. To avoid quenching the magnet, the charging rate is therefore limited and the temperature of the main coil is monitored with two sensors on the display of the power supply.

Persons in charge

- Approved persons of the customer, Bruker Service

Precondition

- After system cool down the magnet must be kept below 3.5 K for at least 4 hours before the energizing procedure can be started.
- Power supply E700–1083 connected.

NOTICE

The supplied documentation must be read and understood before operating the power supply. Refer to the following manuals listed in section [“Further Applicable Documentation” on page 73](#):

- “Technical Manual Power Supply” P/N W122074
(file name: W119018 technical.pdf)
- “Description of E700–1083”
(file name: cryo PS E700_1083.pdf)

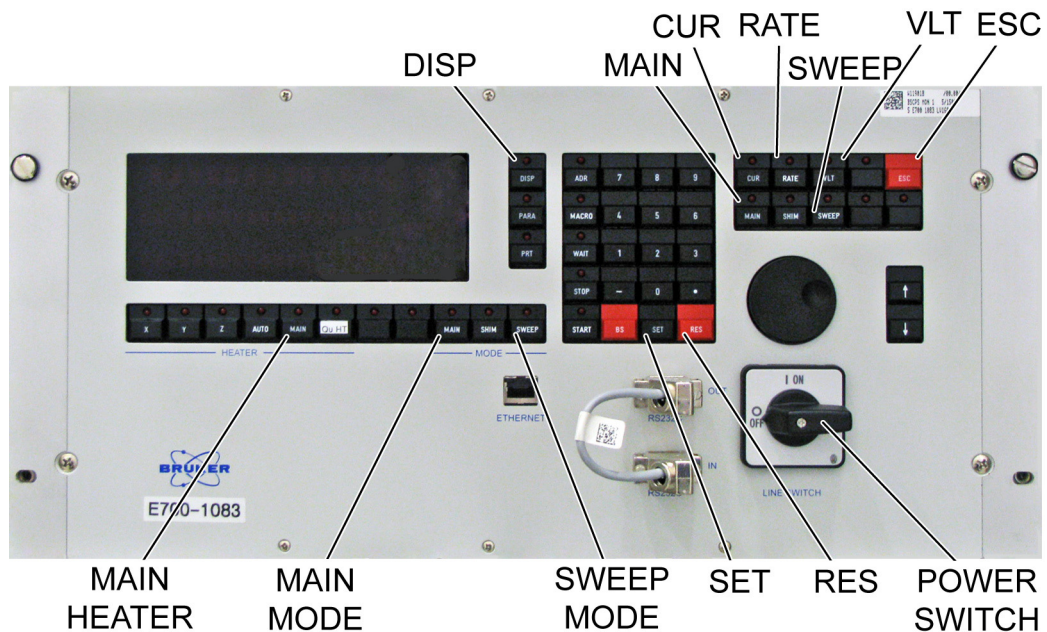

Figure 5.11: Front panel of the power supply E700–1083

5.4.2 First Steps

- Activate the power switch of the E700–1083 power supply.
- Press “RES”
(Reset the interlock status if necessary, see solution key B in [“Troubleshooting” on page 47](#)).
- Check the different displays as described in the power supply manual “Description of E700–1083” (cryo PS E700_1083.pdf).
Press “DISP” to toggle through the different display modes:
 - a) In the “DISPLAY MAIN” mode the main current of the main coil, the voltage and the set values are displayed.
 - b) In the “DISPLAY PT100” mode the temperature of the superconducting current lead is monitored.
 - c) In the “DISPLAY HEATER current” mode the main heater current is displayed.
 - d) In the “DISPLAY SWEEP” mode the sweep current, the set value and the sweep current rate are displayed.
 - e) In the “DISPLAY CERNOX” mode the measured Cernox temperatures of the main coil are displayed.



The “DISPLAY Shim” mode is not relevant for the EPR 12T Cryogen Free magnet as cryo-shims are not implemented.

- Set the current rate and the voltage rate of the main coil (refer to [“Magnet Parameters” on page 67](#)):
 - a) Set the maximum current rate according to [“Magnet Parameters” on page 67](#) while the magnet system is in main mode.
 1. Press “RATE”.
 2. Press “MAIN”.
 3. Enter <Main Coil Current Rate>.
 4. Press “SET” to validate the entry.
 - b) Set the maximum voltage rate according to [“Magnet Parameters” on page 67](#) while the magnet system is in main mode.
 1. Press “RATE”.
 2. Press “VLT”.
 3. Enter <Main Coil Voltage Rate>.
 4. Press “SET” to validate the entry.
- Remark: The “ESC” key allows to leave every program mode without a faulty key press, and also without an “INPUT ERROR” message.

5.5 Cooling Down

Precondition

- Magnet system is evacuated to a vacuum of less than 5×10^{-5} mbar (see section “[Evacuating the Cryostat](#)” on page 28).
- Power supply operation Cernox mode.
- BCFC checked.

Procedure (Water cooled compressor unit F-50H)

- Make sure that the switches (1) and (2) are in default mode as indicated on the yellow labels (see [Figure 5.12](#)).
- Start the compressor F-50H using the switch “DRIVE” on the front panel of the compressor (see [Figure 5.12](#)).
- The rhythmic noise of the cold head will immediately start.
- The compressor status is displayed on the BCFC (see “[Remote Compressor Status Display](#)” on page 32). The four indicators of the compressor (temperature okay, gas pressure okay, input power, running) must be active (green).
- Use the “DISPLAY CERNOX” mode of the power supply to monitor the temperature of the main coil. Cool down procedure from room temperature to base temperature takes up to 96 h.

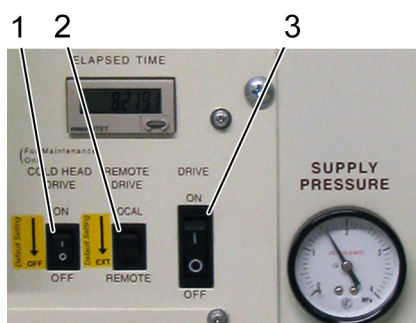

- 1 COLD HEAD DRIVE (For Maintenance Only)
- 2 REMOTE DRIVE
- 3 DRIVE

Figure 5.12: Front panel of the compressor unit F-50H (water cooled)

Procedure (Air cooled compressor unit CNA-61)

- Start the compressor CNA-61 using the “DRIVE SWITCH” on the front panel of the compressor (see [Figure 5.13](#)).
- The rhythmic noise of the cold head will immediately start.
- The compressor status is displayed on the BCFC (see “[Remote Compressor Status Display](#)” on page 32). The four indicators of the compressor (temperature okay, gas pressure okay, input power, running) must be active (green).

- Use the “DISPLAY CERNOX” mode of the power supply to monitor the temperature of the main coil. Cool down procedure from room temperature to base temperature takes up to 96 h.

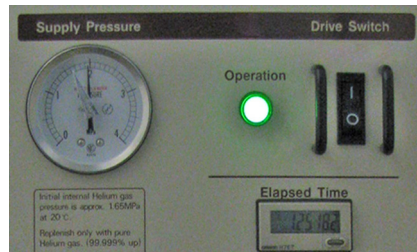

Start the compressor CNA-61 using the “DRIVE SWITCH”.

Figure 5.13: Front panel of the compressor CNA-61 (air cooled)

5.6 Operation of the BCFC

5.6.1 Compressor Status Check

Precondition

- System is set-up as described in section [“Assembling” on page 25](#).
- Compressor is running.

Procedure

Check the compressor status on the front panel of the BCFC. The four green LEDs have to be “ON” and indicate that:

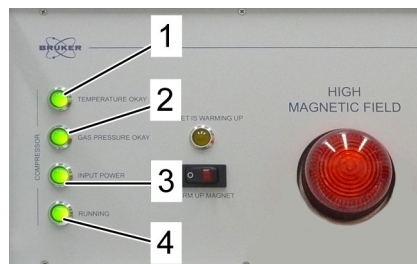

- TEMPERATURE OKAY (1)
- GAS PRESSURE OKAY (2)
- INPUT POWER (3)
- RUNNING (4)

Figure 5.14: Display of the compressor status on the BCFC front panel

If any of the LEDs is OFF, refer to the compressor manual to check the failure of the compressor.

5.6.2 Emergency Button Test

The functionality of the emergency button “MAGNET QUENCH” must be checked on a regular basis (at zero field!).

Precondition

- Compressor status checked.
- Compressor running.
- Magnet system cooled down as described in section “Cooling Down” on page 38.
- Magnet deenergized.
- Magnet temperatures displayed on the power supply (see Table A.9, Table A.10 and Table A.11).

i The check of the magnet quench button must be performed once after installation of the BCFC, and later periodically, at least once a year (see “Maintenance Schedule” on page 51).

Procedure



Figure 5.15: Emergency button MAGNET QUENCH on the BCFC front panel

Push the red emergency button “MAGNET QUENCH”. The rhythmic noise of the cryocooler should stop immediately, and the red indicator “TRIGGERED” on the BCFC must turn ON. Both Cernox temperatures on the power supply will rise to reach 8 K after a few minutes. If any of those actions will not occur, refer to section “Troubleshooting” on page 47.

After the test, unlock the red emergency button by turning it in clockwise direction. The cryocooler should start immediately, the red indicator “TRIGGERED” on the BCFC will go out and the temperatures displayed on the power supply will slowly decrease. Wait for one hour after reaching the base temperature (3.5 K).

5.6.3 Energizing the Magnet

Precondition

- Magnet system at base temperature (less than 3.5 K).
- All green indicators on the front panel of the BCFC "ON".
- Safety check passed.



Figure 5.16: Energizing the magnet and checking the indicator

Procedure

Energize the magnet according to section [“Energizing and Deenergizing in Main Mode” on page 44](#). Watch the field indicator. The indicator must become active (ON) before the magnet reaches 1 T (10 Amps). If the indicator remains inactive (OFF), refer to the troubleshooting section of this manual (see [“Troubleshooting” on page 47](#)).



Do not operate the magnet system with a defective magnetic field indicator.

5.6.4 Emergency Quench

Precondition

- “HIGH MAGNETIC FIELD” indicator is ON;
- Indicator “ARMED” is ON.

Procedure

1. Push the magnet quench button.
2. Check that the rhythmic noise of the compressor stops and the red indicator (“TRIGGERED”) is ON.
3. Wait until the magnetic field indicator is turned OFF. It can take up to a few minutes until the magnetic fringe field has disappeared after pushing the emergency button “MAGNET QUENCH”.



Figure 5.17: Quenching the magnet in an emergency case

5.6.5 Warming up the Magnet

Precondition

- Magnet deenergized (refer to [“Energizing and Deenergizing in Main Mode”](#) on page 44)
- Magnet cold (below 300 K)

Procedure

1. Turn off the compressor (see [Figure 5.12 on page 38](#) and [Figure 5.13 on page 39](#)).
2. Activate the switch “WARM UP MAGNET”. This switch is activated if the indicator within the switch is active. If both preconditions are fulfilled, the heater is being activated. Only exception: AC power failure.
It takes up to ~ 2 days for warming up the system. The heater is being deactivated if the magnet is at 300 K.
3. Deactivate the “WARM UP MAGNET” switch. Check if the indicator within the switch is OFF:



Figure 5.18: After work / service: warming up the magnet system

5.7 Power Supply Operation

5.7.1 Selecting the Operation Mode

Select the Sweep Mode:

- The current in the current leads has to be zero.
- Press "SWEEP MODE".
- Press "SET".

Select the Main Mode:

- The current in the current leads has to be zero.
- Press "MAIN MODE".
- Press "SET".

5.7.2 Energizing and Deenergizing in Main Mode

Calculate the current required in the main coil to achieve the desired field by multiplying the field with the ratio "Main Current / Magnetic Field" as indicated in ["Magnet Parameters" on page 67](#).

Perform the following steps to change the field:

- Select the main mode (see ["Selecting the Operation Mode" on page 44](#)).
- Limit the maximum voltage to 0.05 V:
 1. Press "VLT"
 2. Enter value <0.05>
 3. Press "SET" to validate the entry.
- Drive the current in the current leads to the actual current in the main coil:
 1. Press "CUR"
 2. Press "MAIN"
 3. Enter value <Actual Main Current in Amperes>
 4. Press "SET" to validate the entry.
 5. Wait until the current in the current leads has reached the current in the main coil.
- Open the main switch:
 1. Press "MAIN HEATER"
 2. Enter value <1> to heat the main switch
 3. Press "SET" to validate the entry
 4. Wait for 2 minutes.



The magnet achieves the driven mode ~ 2 minutes after the main switch is heated.

- Define the maximum voltage for the energizing/deenergizing procedure:
 1. Press "VLT"
 2. Enter <Max. Voltage in Volts>
 3. Press "SET" to validate the entry.

i The value "Max. Voltage in Volts" cannot exceed the value "U main level" defined in "[Power Supply Parameters](#)" on page 68. This value is defined for four different current ranges "I main level 1–4".

- Set the new current to which the main coil is charged/discharged:
 1. Press "CUR"
 2. Press "MAIN"
 3. Enter <Main Current in Amperes>
 4. Press "SET" to validate the entry. The main current is changed to the new current.
 5. Wait until the current reaches the set value and the voltage approaches to zero.

i The value of "Main Current in Amperes" cannot exceed the "I max main current" defined in "[Power Supply Parameters](#)" on page 68.

- Limit the maximum voltage to 0.05 V:
 1. Press "VLT"
 2. Press <0.05>
 3. Press "SET" to validate the entry.
- Close the main switch:
 1. Press "MAIN HEATER"
 2. Press <0> to stop heating the main switch
 3. Press "SET" to validate the entry
 4. Wait for 4 minutes.

i The magnet achieves the persistent mode ~ 4 minutes after the main switch heater is turned off.

- Drive the current in the leads to zero:
 1. Press "CUR"
 2. Press "MAIN"
 3. Enter <0>
 4. Press "SET" to validate the entry.

5.7.3 Energizing and Deenergizing in Sweep Mode

Calculate the current required in the sweep coil current to achieve the desired field change by multiplying the field with the ratio "Sweep Current / Magnetic Field" in "[Magnet Parameters](#)" on page 67.

Perform the following steps to change the field in the sweep coil:

- Select the sweep mode (see "[Selecting the Operation Mode](#)" on page 44).
- Set the current rate of the sweep coil to a desired value:
 1. Press "RATE"
 2. Press "SWEEP"
 3. Enter <Sweep Current Rate in Amperes/Minute>
 4. Press "SET" to validate the entry.

i The value of the "Sweep Current Rate in Ampere/Minute" cannot exceed the "Sweep rate fast" defined in "[Power Supply Parameters](#)" on page 68. In case the current in the main coil is above "I main rate sweep slow/fast" the value of the "Sweep Current Rate in Ampere/Minute" cannot exceed "Sweep rate slow".

- Energize/deenergize the sweep coil to the desired current value:
 1. Press "CUR"
 2. Press "SWEEP"
 3. Enter <Sweep current in amperes>
 4. Press "SET" to validate the entry. The sweep current is changed to the new current.

i The set value of the "Sweep current in amperes" cannot exceed the "I max sweep current" defined in "[Power Supply Parameters](#)" on page 68.

6 Troubleshooting

In case of doubts or problems not specified in the following list contact Bruker Service immediately (see [page 5](#) of this document for contact information).

6.1 Safety

WARNING



Magnetic Fields (see [page 13](#))

Gas under Pressure (see [page 15](#))

Power Supply (see [page 19](#))

Persons

Bruker Service, approved persons of the customer (see [page 9](#)).

6.2 Problems

The following table gives a summary of problems which may require troubleshooting action to be carried out either by approved persons of the customer or by Bruker Service. Possible reasons indicated in the list of problems refer to solution keys and detailed description of solutions listed in [Table 6.2](#) and [Table 6.3](#).

Problem Indicator	Possible Reason	Solution (Key)	By
Cool-down rate too small, temperature does not decrease below an intermediate value	Vacuum is not established or is too poor (less than 5×10^{-5} mbar)	A	Customer
Setting current on power supply is not possible	Power supply in interlock mode	B	Customer
No data entry accepted from power supply front panel	Power supply is in remote mode	C	Customer
Energizing or deenergizing the magnet not possible	Heater current for switch heater is too low	D	Bruker Service
	Switch heater damaged	E	Bruker Service
EPR signal disappeared due to continuous magnet deenergizing	Sense voltage > 0 V due to opening of superconducting switch	F	Customer
Magnetic field indicator OFF	Indicator module not properly inserted	G	Customer
	Magnet quench due to compressor failure after power outage	H	Customer
	Magnet quench due to compressor failure after failure of cooling water supply	I	Customer
	Magnet quench due to insufficient magnet cooling	K	Bruker Service
Activating warm-up switch of BCFC has no effect (magnet is not warming up)	Magnet is energized	L	Customer
	Magnet is already warm (room temperature)	M	Customer
Yellow indicator of the BCFC activated	UPS battery defective	N	Bruker Service
Emergency button test failed	Not specified	O	Customer

Table 6.1: Troubleshooting table

6.3 Solutions

Key	Solution
A	Rebuild vacuum as described in section "Rebuilding Vacuum" on page 30 .
B	<p>Press "RES" to reset the power supply.</p> <p>Additional information: For the EPR 12T Cryogen Free system the interlocks based on the magnet temperature are not in use. Therefore the threshold values have been set to 300 K (see section "Power Supply Parameters" on page 68). However, the interlocks can get triggered due to an overcurrent or an overheating in the power supply or after the system has been cooled down from room temperature.</p>
C	<ol style="list-style-type: none"> 1. Press "PRT" to change the local/remote mode. 2. Enter value <0> to activate the local mode. 3. Press "SET" to validate.
D	Set value for the heater current (see "Power Supply Parameters" on page 68).
E	System repair by Bruker required.
F	<ol style="list-style-type: none"> 1. Deenergize the magnet system to 0 T. 2. Wait until the base temperature is reached. 3. Energize the magnet.
G	Insert module properly.
H	<ol style="list-style-type: none"> 1. Restore power. 2. Set the current on the power supply to zero. 3. Cool down the magnet to base temperature. 4. Energize the magnet.
I	<ol style="list-style-type: none"> 1. Restore cooling water. Enhance reliability of cooling water supply. 2. Set the current on the power supply to zero. 3. Cool down the magnet to base temperature. 4. Energize the magnet.

Table 6.2: Solution keys (part 1)

(continued)

Key	Solution
K	<ol style="list-style-type: none">1. Set the current on the power supply to zero.2. Cool down the magnet to base temperature (indicated on the power supply).3. Read and write down the base temperature (see "Base Temperature Report (Monthly)" on page 71).4. Send all information from the base temperature report to Bruker Service.
L	<ol style="list-style-type: none">1. Deenergize the magnet.2. Activate the warm-up switch.
M	none
N	Replace UPS battery.
O	Contact Bruker Service (for contact information see page 5).

Table 6.3: Solution keys (part 2)

7 Maintenance

Maintenance Schedule

Maintenance Work	Maintenance Interval	Responsibility
Record the base temperature of the magnet system (refer to Table A.12 on page 71)	once per month	Approved customer personnel
Record elapsed time of the compressor	once per month	Approved customer personnel
Cleaning air cooler	at least once per year	Approved customer personnel
Check the emergency button "MAGNET QUENCH" at zero field	once per year	Approved customer personnel
Replace cold head for refurbishment of sliding parts of the cold head	every 10 000 hours	Bruker Service
Replace compressor adsorber	every 20 000 hours	Bruker Service
UPS battery replacement	every 4 – 5 years	Bruker Service
Charge helium gas to compressor	as required	Bruker Service
Compressor fuse replacement	as required	Bruker Service

Table 7.1: Maintenance schedule of the EPR 12T magnet system

- For maintenance of the power supply refer to the supplied manual (see ["Further Applicable Documentation" on page 73](#)).
- For details of the maintenance schedule of the compressor unit refer to the supplied manual "Technical Instruction F-50H Compressor Unit" (see ["Further Applicable Documentation" on page 73](#)).
- For details of the maintenance schedule of the cold head refer to the supplied manual "Technical Instruction RDK-415D 4K Cold Head" (see ["Further Applicable Documentation" on page 73](#)).

8 Disassembling

8.1 Safety

Persons in charge: Bruker Service only.

A Appendix

A.1 Warning Signs

Danger

Key words and symbols	11
-----------------------------	----

Warning

Blocked safety devices	19
Electricity, high voltage	13
High magnetic fields	13
Incorrect use of the magnet system	12
Inserting and removing the VTI	14
Key words and symbols	11
Not approved persons	12
Not readable signs and labels	17
Risk of tilting	15

Caution

Cryogenic refrigerator	14
Incorrect transportation	16
Key words and symbols	11

Notice

Hazard, which could result in material damage	11
Magnet quench button	34
Vibration during transportation	23

A.2 Figures

Figure 1.1:	Overview of the EPR magnet system	8
Figure 3.1:	Packaging	22
Figure 3.2:	Transportation by forklift / pallet jack	24
Figure 5.1:	Vacuum valve assembly	28
Figure 5.2:	Vacuum valve mounted on the magnet system	28
Figure 5.3:	Removing the earthing cable	29
Figure 5.4:	Mounting the vacuum valve at the evacuated cryostat	29
Figure 5.5:	Rebuilding vacuum	30
Figure 5.6:	Removing the vacuum valve	31
Figure 5.7:	Mounting the earthing cable	31
Figure 5.8:	Bruker Cryogen Free Controller (BCFC) – Front View	32
Figure 5.9:	Bruker Cryogen Free Controller (BCFC) – Rear View	34
Figure 5.10:	Magnet quench indicators on the BCFC front panel	34
Figure 5.11:	Front panel of the power supply E700–1083	36
Figure 5.12:	Front panel of the compressor unit F–50H (water cooled)	38
Figure 5.13:	Front panel of the compressor CNA-61 (air cooled)	39
Figure 5.14:	Display of the compressor status on the BCFC front panel	39
Figure 5.15:	Emergency button MAGNET QUENCH on the BCFC front panel	40
Figure 5.16:	Energizing the magnet and checking the indicator	41
Figure 5.17:	Quenching the magnet in an emergency case	42
Figure 5.18:	After work / service: warming up the magnet system	43
Figure A.1:	Dimensions of the cryostat (front view)	64
Figure A.2:	Dimensions of the cryostat (top view)	65
Figure A.3:	Fringe field plot of the EPR 12T magnet system	66

A.3 Tables

Table 6.1:	Troubleshooting table.....	48
Table 6.2:	Solution keys (part 1)	49
Table 6.3:	Solution keys (part 2)	50
Table 7.1:	Maintenance schedule of the EPR 12T magnet system	51
Table A.1:	Glossary	61
Table A.2:	Abbreviations	61
Table A.1:	Components of the EPR 12T magnet system.....	63
Table A.2:	Weight of the magnet system	63
Table A.3:	Dimensions for transportation of the magnet system.....	63
Table A.4:	Dimensions of the cryostat – front view	65
Table A.5:	Dimensions of the cryostat – top view	65
Table A.6:	Fringe field of the EPR 12T magnet system at maximum field.	66
Table A.7:	Specification of the EPR magnet system	67
Table A.8:	Magnet parameters of the main coil and of the sweep coil.....	67
Table A.9:	Parameters to be set in the PARA menu during installation of the power supply (part 1).....	68
Table A.10:	Parameters to be set in the PARA menu during installation of the power supply (part 2).....	69
Table A.11:	Parameters to be set in the PARA menu during installation of the power supply (part 3).....	70
Table A.12:	Base temperature report (monthly)	71
Table A.13:	Base temperature report (monthly)	72
Table A.14:	Spare parts and accessories.....	73
Table A.15:	List of external documents	73

A.4 Glossary / Abbreviations

Used term	Description
Base Temperature	Lowest temperature that can be achieved by a cryogenic refrigerator.
Box	Any kind of package used to protect sensitive parts during transportation.
Cryostat	The collective of all parts providing a temperature of 4 K inside for the superconducting magnet. The cryostat also provides the safety devices and the access ports for electricity. The superconducting magnet inside the cryostat is not energized.
Magnet System	The collective of all parts necessary for the intended use. The superconducting magnet inside the cryostat is energized.

Table A.1: Glossary

Abbreviations	Description
BCFC	Bruker Cryogen Free Controller
CF	Cryogen Free
EPR	Electron Paramagnetic Resonance
RT	Room Temperature; used for room temperature level and as prefix of parts which are at room temperature
UPS	Uninterruptible Power Supply
VTI	Variable Temperature Insert

Table A.2: Abbreviations

A.5 Technical Data

A.5.1 Components

Component	Type
Magnet System	MS EPR 12T CF
Cryogenic Refrigerator consists of <ul style="list-style-type: none">• 4K Cold Head• Compressor Unit	RDK-415D F-50H (water cooled) CNA-61 (air cooled)
Bruker Cryogen Free Controller	BCFC
Power Supply	E700-1083

Table A.1: Components of the EPR 12T magnet system

A.5.2 Dimensions

A.5.2.1 Weights

	Value	Unit
Magnet system	480	kg

Table A.2: Weight of the magnet system

A.5.2.2 Dimensions for Transportation

	Value	Unit
Height	1942	mm
Width	596	mm
Depth	1193	mm

Table A.3: Dimensions for transportation of the magnet system

A.5.3 Cryostat Dimensions

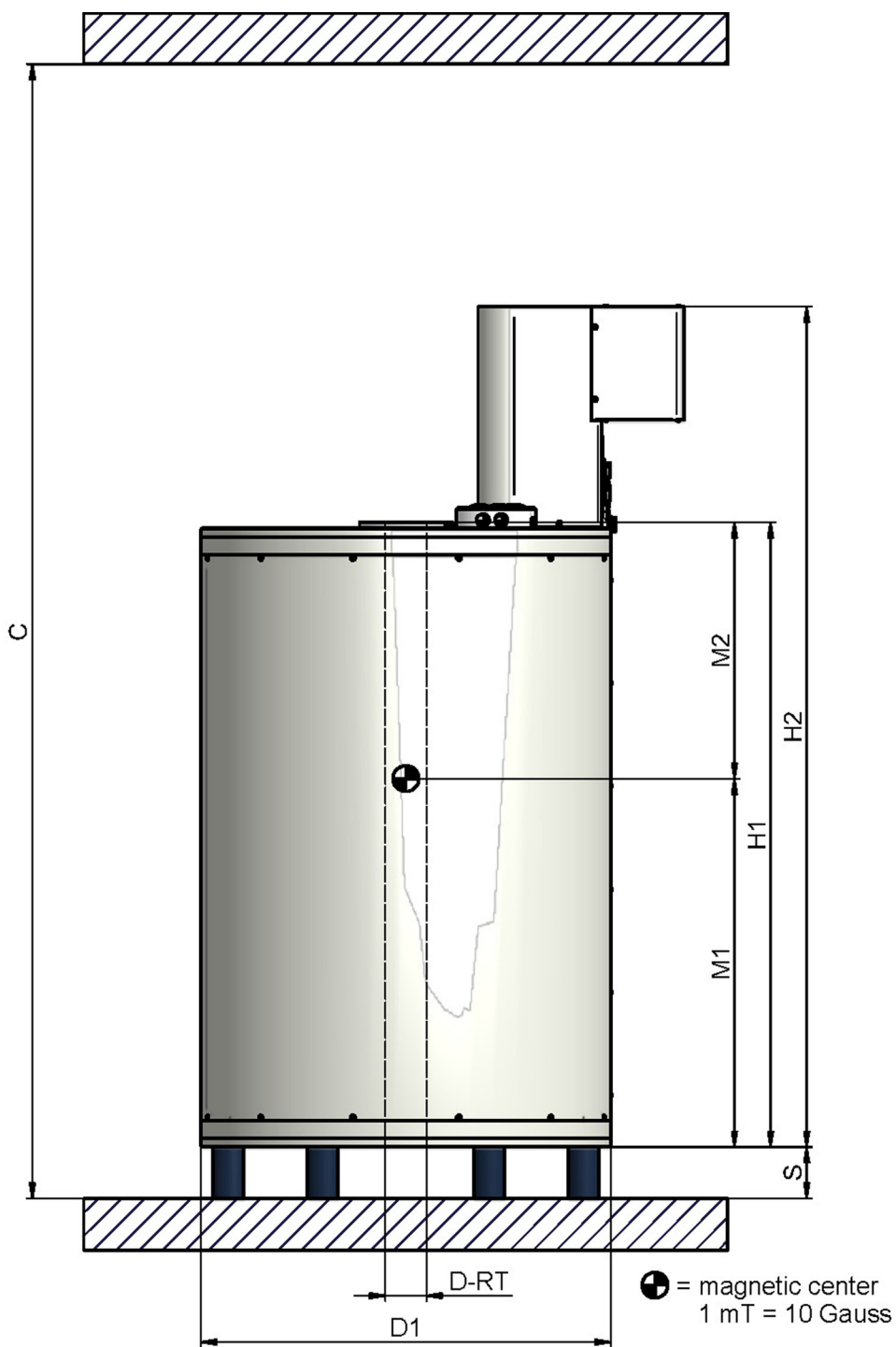

Z1047107

Figure A.1: Dimensions of the cryostat (front view)

Cryostat Dimensions	Value	Unit
H1 Height of cryostat (without cold head)	1212	mm
H2 Height of cryostat (including cold head)	1630	mm
D1 Cryostat diameter	795	mm
D-RT RT bore diameter	80	mm
M1 Distance magnetic center – bottom plate (calculated)	715	mm
M2 Distance magnetic center – top flange	497	mm
C Ceiling height, recommended for operation	2500	mm
S Height of pillars	100	mm

Table A.4: Dimensions of the cryostat – front view

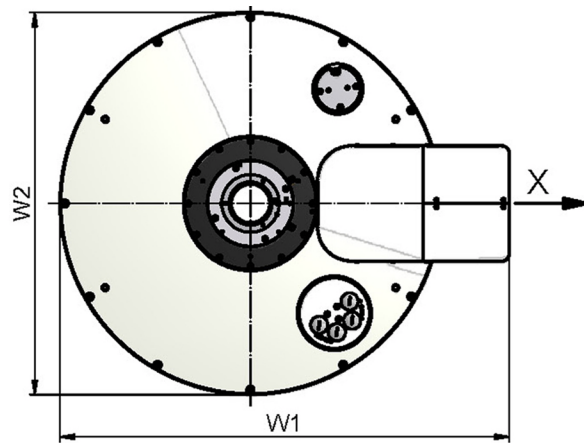

Figure A.2: Dimensions of the cryostat (top view)

Cryostat Dimensions	Value	Unit
W1	940	mm
W2	795	mm

Table A.5: Dimensions of the cryostat – top view

A.5.4 Specifications

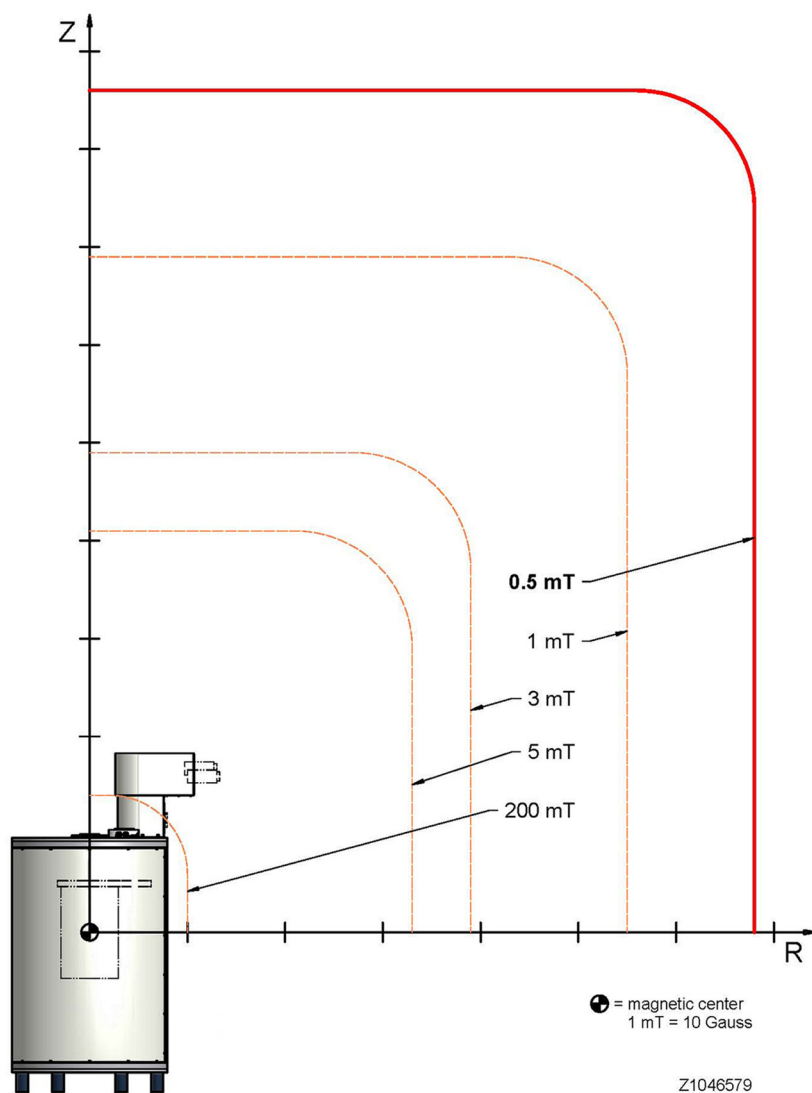

Figure A.3: Fringe field plot of the EPR 12T magnet system
Scale division is 0.5 m. The magnetic center is 814.5 mm above floor level.

Fringe Field	R (m)	Z (m)
0.5 mT	3.40	4.30
1 mT	2.75	3.45
3 mT	1.95	2.45
5 mT	1.65	2.05
200 mT	0.50	0.70

Table A.6: Fringe field of the EPR 12T magnet system at maximum field.

Magnet Specifications

Description	Value	Unit
Homogeneity in 10 mm DSV (DSV = diameter of spherical volume)	≤ 10	ppm
Energizing time to 12 T	< 100	min
Field stability Persistent Mode (1 day after energizing)	≤ 2	ppm / day
Radial fringe field (horizontal distance of the 0.5 mT (5 G) line from the magnetic center)	< 3.4	m
Axial fringe field (vertical distance of the 0.5 mT (5 G) line from the magnetic center)	< 4.3	m
Magnet free bore	80	mm
Main coil inductance	99	H

Table A.7: Specification of the EPR magnet system

Magnet Parameters

Description	Value	Unit
Main Coil		
Main current / magnetic field	_____	A / T
Main coil current rate	60	A / min
Main coil voltage rate	5	V / min
Sweep Coil		
Sweep current / magnetic field	_____	A / T

Table A.8: Magnet parameters of the main coil and of the sweep coil

A.5.5 Power Supply Parameters

To enter the parameters into the power supply a service code is requested. Only Bruker Service is allowed to set the parameters in the PARA menu of the power supply (Table A.9, Table A.10 and Table A.11).

Use the UP/DOWN buttons of the power supply to navigate in the PARA menu.

i Once the parameters have been set via the PARA menu, the power supply and the magnet system are configured specifically. Thus, after parameter setting the configuration represents a unique hardware assignment and components thereof must not be changed arbitrarily.

EPR 12T Cryogen Free, Serial No. _____				
Position	Explanation	Command	Unit	Value
0	Enter service code	COD=, COD/	–	–
1	Memory shim?	SHM=	–	–
2	Init shim mem?	RSH=	–	–
3	Heater detection?	DET=	–	–
4	PS values to default?	RSP=	–	–
5	Shim off time	PA1/, PA1=	s	5
6	Shim on time	PA2/, PA2=	s	5
7	Shim cur according ht X	PA3/, PA3=	A	0
8	Shim cur according ht Y	PA4/, PA4=	A	0
9	Shim cur according ht Z	PA5/, PA5=	A	0
10	I max main current	IMM/, IMM=	A	_____
11	I max sweep current	IMS/, IMS=	A	40
12	I main level 1	CM1/, CM1=	A	40
13	U main level 1	VM1/, VM1=	V	3.2
14	I main level 2	CM2/, CM2=	A	70
15	U main level 2	VM2/, VM2=	V	3.2
16	I main level 3	CM3/, CM3=	A	100

Table A.9: Parameters to be set in the PARA menu during installation of the power supply (part 1)

EPR 12T Cryogen Free, Serial No. ____				
Position	Explanation	Command	Unit	Value
17	U main level 3	VM3/, VM3=	V	3.2
18	I main level 4	CM4/, CM4=	A	____
19	U main level 4	VM4/, VM4=	V	2
20	I main heater	IMH/, IMH=	mA	35
21	R main heater	RMH/, RMH=	Ω	100
22	Sweep rate slow	SRL/, SRL=	A/min	____
23	Sweep rate fast	SRF/, SRF=	A/min	40
24	I main rate sweep slow/fast	ISR/, ISR=	A	100
25	Shim max rate	SMR/, SMR=	A/min	5
26	Shim heater current	SHC/, SHC=	mA	30
27	Quench heater current	QHC/, QHC=	mA	0
28	Quench heater ON time	QHT/, QHT=	s	1
29	Enable quench heater button	EQH/, EQH=	–	0
30	Temp level 1 for PT100	TP1/, TP1=	K	300
31	Temp level 2 for PT100	TP2/, TP2=	K	300
32	Cernox S1 R1	C11/, C11=	Ω	____
33	Cernox S1 R2	C12/, C12=	Ω	____
34	Cernox S1 R3	C13/, C13=	Ω	____
35	Cernox S1 R4	C14/, C14=	Ω	____
36	Cernox S1 R5	C15/, C15=	Ω	____
37	Cernox S1 R6	C16/, C16=	Ω	____
38	Cernox S2 R1	C21/, C21=	Ω	____
39	Cernox S2 R2	C22/, C22=	Ω	____
40	Cernox S2 R3	C23/, C23=	Ω	____

Table A.10: Parameters to be set in the PARA menu during installation of the power supply (part 2)

EPR 12T Cryogen Free, Serial No. ____				
Position	Explanation	Command	Unit	Value
41	Cernox S2 R4	C24/, C24=	Ω	_____
42	Cernox S2 R5	C25/, C25=	Ω	_____
43	Cernox S2 R6	C26/, C26=	Ω	_____
44	Tc1 50 A	C1a/, C1a=	K	300
45	Tq1 50 A	Q1a/, Q1a=	K	300
46	Tc1 70 A	C1b/, C1b=	K	300
47	Tq1 70 A	Q1b/, Q1b=	K	300
48	Tc1 90 A	C1c/, C1c=	K	300
49	Tq1 90 A	Q1c/, Q1c=	K	300
50	Tc1 110 A	C1d/, C1d=	K	300
51	Tq1 110 A	Q1d/, Q1d=	K	300
52	Tc2 50 A	C2a/, C2a=	K	300
53	Tq2 50 A	Q2a/, Q2a=	K	300
54	Tc2 70 A	C2b/, C2b=	K	300
55	Tq2 70 A	Q2b/, Q2b=	K	300
56	Tc2 90 A	C2c/, C2c=	K	300
57	Tq2 90 A	Q2c/, Q2c=	K	300
58	Tc2 110 A	C2d/, C2d=	K	300
59	Tq2 110 A	Q2d/, Q2d=	K	300
60	Set serial number	SNB/, SNB=	–	1

Table A.11: Parameters to be set in the PARA menu during installation of the power supply (part 3)

A.5.7 Other Applicable Documentation

List of Spare Parts and Accessories

Description	Type	Material No.	Usage
O-ring	57 x 2.5	40695	Vacuum valve
O-ring	44 x 2.5	40693	Vacuum valve
O-ring	36.14 x 2.5	40692	Vacuum valve
Vacuum valve	Bruker	Z53420	Vacuum Valve
Earthing cable	Bruker	W122068	Safety device
Battery for UBC10.241	12 V, 5 Ah		UPS

Table A.14: Spare parts and accessories

Further Applicable Documentation

Name	Type	Document
W122074	Technical Manual, Power Supply BSCPS MON 1 5/150C5 E700 1083 LV160	W119018 technical.pdf
W119018	Description of Cryo Power Supply E700–1083	cryo PS E700_1083.pdf
RDK–415D 4 K Cold Head	Technical Instruction (for service personnel only)	Manual_RDK415.pdf Manual Number CD32ZZ-070J
F–50H Compressor Unit	Technical Instruction (for service personnel only)	Technical_Instruction_F50H.pdf Manual Number CD32ZZ-226E
UPS	Specification of PULS Dimension U-Series, Uninterruptible Power Supply Model: UBC10.241	jnUBC10-241_data_e.pdf
Wiring Diagram	Wiring BCFC	BCFC_Verdrahtung_10_A.pdf Rev. 1.0, Index A last updated: Febr 04, 2011
List of spare parts	BCFC	Stückliste_Austauschteile.pdf

Table A.15: List of external documents

A.6 Index

A

Abbreviations	61
Assembly	25

B

Base Temperature Report	71
BCFC	
Magnet Quench Indicators	34
Magnetic Field Indicator	33
Remote Compressor Status Display ...	32

C

Cernox	
Display Cernox Mode	36
Para Menu Settings	69
Compressor	
Drive Switch CNA-61	36, 37, 39
Drive Switch F-50H	38
Remote Status Display	32
Status Check	39
Contact	5
Cooling Down	38

D

Dimensions	
Cryostat	65
Dimensions for Transportation	63
Disassembly	53
Documentation, Other Applicable Documentation	73

E

Electricity	13
Emergency Situations	20
Energizing the Magnet	41
EPR 12T CF	
Electron Paramagnetic Resonance 12T	
Cryogen Free	35
Evacuating the Cryostat	28

F

Fire Department	20
-----------------------	----

G

Glossary	61
----------------	----

H

Height	
Ceiling Height	65
Height Cryostat	65

I

Intended Use	12
Interlocks	49

L

Liability	7
-----------------	---

M

Magnetic Field	13
Hazard from Magnetic Field	42
Indicator	33
Main Current / Magnetic Field	67
Maintenance Schedule	51
Manufacturer, Bruker BioSpin	5

P

Para Menu	
Power Supply Parameters	68
Parameters	
Magnet Parameters	67
Main Coil	67
Main Coil Parameters	67
Power Supply Parameters	68
Sweep Coil	67
Power Supply	
Description	73
Display	36
Maintenance	51
Parameters	68
Technical Manual	73

Q

Quench	19
Emergency Button	40
Emergency Button Test	40

R

Remote	
Compressor Status Display	32
Magnet Quench Function	33
Rescue Equipment	20

S

Safety Devices	
Drop-off Plate	19
Emergency Quench	19, 41, 45, 46
Shock Watch	22
Specifications	
Magnet Parameters	67
Magnet Specifications	67

T

Technical Data	63
Tilt Watch	22
Tilting	15
Transportation, Dimensions for Transportation	63
Troubleshooting	
Problems	48
Solutions	49

U

UPS, Uninterruptible Power Supply ...	33
---------------------------------------	----

V

Vacuum Valve	28
Mounting the Vacuum Valve	29
Rebuilding Vacuum	30
VTI, Variable Temperature Insert	14

W

Warming up	
Procedure	43
Warm up Magnet Switch	43
Warranty	7
Weights	
Magnet System	63

**EPR 12T Cryogen Free
User Manual**

Revision History List

Index:	Date:	Alteration Type:
00	April 2011	First release of "EPR 12T Cryogen Free, User Manual", Rev. 00

Bruker, your solution partner

Bruker provides a world class, market leading range of analytical solutions for your molecular and material research needs. Our solution-oriented approach enables us to work closely with you to identify your specific needs and determine the best solution package for you from our comprehensive range. Furthermore, we offer you the opportunity to collaborate with us on new developments.

Our ongoing efforts and substantial investment in research and development demonstrate our long term commitment to technological innovation on behalf of our customers. With 50 years of experience in meeting the needs of the scientific community across a range of specialist disciplines, Bruker has built a sound rapport with professionals from the community through understanding specific requirements.

This cooperative relationship with our customers allows us to provide them with effective solutions and a service of unmatched quality.



info@bruker.com
www.bruker.com

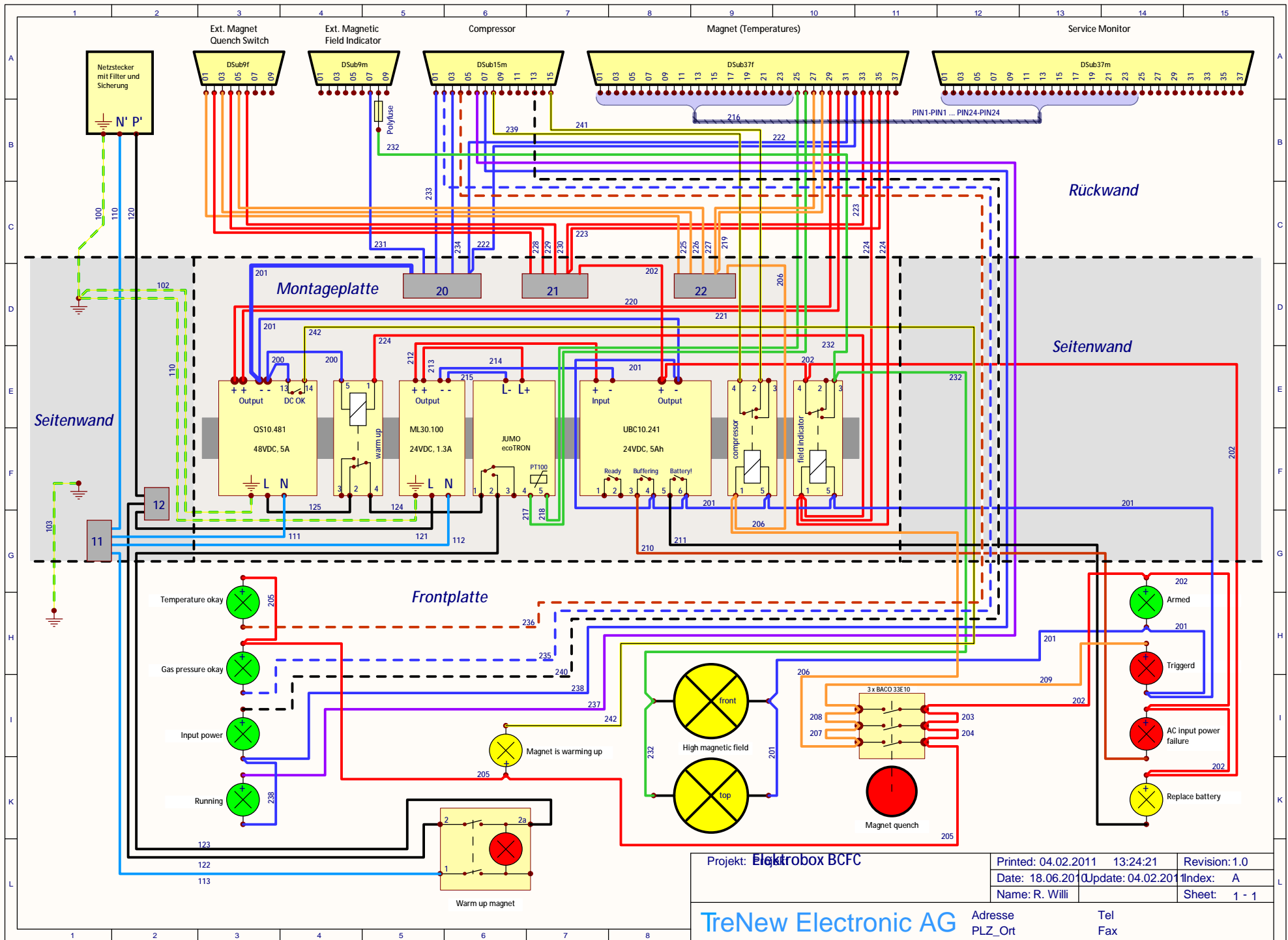

Projekt: Elektrobox BCFC	Printed: 04.02.2011 13:24:21	Revision: 1.0
	Date: 18.06.2010 Update: 04.02.2011	Index: A
	Name: R. Willi	Sheet: 1 - 1

TreNew Electronic AG Adresse Tel
 PL_Z_Ort Fax