

# Fourier 300

- Console  
Service Manual  
Version 003



Copyright© by Bruker Corporation

All rights reserved. No part of this publication may be reproduced, stored in a retrieval system, or transmitted, in any form, or by any means without the prior consent of the publisher. Product names used are trademarks or registered trademarks of their respective holders.

This manual was written by

Diether Maier and Frank Decker

© December 21, 2011: Bruker Corporation

Rheinstetten, Germany

P/N: Z31980

DWG-Nr.: Z4D11520B

For further technical assistance on the Fourier 300 unit, please do not hesitate to contact your nearest BRUKER dealer or contact us directly at:

BRUKER Corporation  
am Silberstreifen  
D-76287 Rheinstetten  
Germany

Phone:+ 49 721 5161 0  
FAX:+ 49 721 5171 01  
E-mail:service@bruker.de  
Internet:www.bruker.com

---

<b>1</b>	<b>About .....</b>	<b>7</b>
1.1	This Manual .....	7
1.2	Policy Statement .....	7
1.3	Symbols and Conventions.....	7
<b>2</b>	<b>Introduction.....</b>	<b>9</b>
2.1	Concept .....	9
2.2	Limitation of Liability .....	10
2.3	Before you begin .....	10
2.4	Minimum Qualifications for Service Personnel.....	11
2.5	The Bruker Service.....	11
2.6	Transport to Manufacturer.....	11
<b>3</b>	<b>Safety.....</b>	<b>13</b>
3.1	General.....	13
3.2	Personnel Requirements.....	13
3.2.1	Qualifications .....	13
3.2.2	Unauthorized Persons.....	14
3.3	Personal Protective Equipment.....	14
3.4	Basic Dangers .....	14
3.4.1	General Workplace Dangers .....	15
3.4.2	Dangers from Electric Power.....	16
3.4.3	Mechanical Dangers.....	18
3.4.4	Dangers from Gases Under Pressure .....	19
3.4.5	Dangers from Radiation .....	20
3.4.6	Dangers Due to High or Low Temperatures.....	21
3.4.7	Danger from Chemical Substances.....	22
3.5	Environmental Protection .....	23
3.6	Signage .....	24
3.7	Spare Parts .....	25
<b>4</b>	<b>Tool Requirements .....</b>	<b>27</b>
<b>5</b>	<b>Design and Function .....</b>	<b>29</b>
5.1	Overview .....	29
5.2	Brief Description .....	29
5.2.1	Internal Console Component Layout.....	31
5.3	Unit Descriptions .....	33
5.3.1	Intelligent Devices with Ethernet .....	33
5.3.1.1	Main Board .....	34
5.3.1.2	Lock System.....	35
5.3.1.3	Variable Temperature Unit (VTU).....	35

5.3.2	Intelligent Devices with Can-Bus .....	35
5.3.2.1	Shim Control.....	36
5.3.2.2	Peripheral Control Board .....	37
5.3.2.3	GAB/2 Backplane .....	37
5.3.3	Intelligent Devices with LVDS.....	37
5.3.4	Devices without Interface .....	37
5.3.4.1	Transmitters.....	38
5.3.4.2	Preamplifiers.....	38
5.3.4.3	Lock Switch .....	38
5.3.4.4	Power Supplies.....	40
5.3.4.5	Ventilators.....	41
5.4	Connections.....	42
5.5	Accessories .....	43
<b>6</b>	<b>Installation.....</b>	<b>45</b>
6.1	Unpacking.....	45
6.2	Wiring Up.....	45
6.3	Adjusting Air Pressure .....	46
6.4	Switch on for the first time .....	46
6.5	Checking that the Console has booted.....	46
6.6	Performing cf on a Fourier.....	48
6.6.1	Setting the spectrometer frequency.....	49
6.6.2	ETH Addresses and tty Settings.....	50
6.6.3	Cortab and Power Check .....	50
6.6.4	Editing the Nuclei List.....	50
6.6.5	RF routing.....	52
6.7	Additional Configurations.....	53
6.7.1	Installation of Pulse Programs and Parameter Sets.....	54
6.7.2	Editing Solvents.....	56
6.7.3	Configuring the Probe.....	57
6.7.4	Configuring the Lock Parameters .....	59
6.7.5	Configuring the Transmitter and Preamplifier Pre-delays.....	61
6.8	Setting the magnet to the right field.....	62
6.9	The Lock System.....	62
6.9.1	Working with the Lock System .....	62
6.9.2	Finding a Lock .....	63
6.10	Converting the Parameter Set to the actual BF1 .....	70
6.11	Tuning and Matching the Probe .....	71
6.11.1	General Information about the Fourier Probe.....	71
6.12	The Gradshim Command .....	71
6.13	Installation Acceptance.....	74
6.14	Main Differences between Fourier & Avance Systems .....	76
<b>7</b>	<b>Configuration.....</b>	<b>77</b>

7.1	Network Settings .....	77
7.1.1	Resetting the CPU.....	79
7.2	Firmware Update.....	79
7.2.1	Ethernet Devices (Main Board, Lock Board, VTU).....	79
7.2.2	4.3.2 CAN-Bus Devices .....	80
7.3	FPGA Update .....	83
7.3.1	Lock Control and VTU .....	83
7.3.2	Main Board.....	84
7.4	Device Specific Settings & Tools.....	85
7.4.1	Main Board.....	86
7.4.1.1	BIS EEPROM Settings .....	86
7.4.1.2	Board Temperature Control.....	88
7.4.1.3	On-Board Voltages.....	90
7.4.1.4	4.5.1.5 Pulse programmer memory .....	90
7.4.2	Shim Control.....	91
7.4.3	GAB/2 Interface.....	95
7.4.4	Lock Board .....	96
7.4.5	VTU .....	105
7.4.5.1	Changing PID parameters.....	106
7.4.5.2	Setting the Heater Protection Threshold .....	107
7.4.5.3	Calibrating the Thermocouple .....	108
7.4.6	Peripheral Control .....	108
7.4.6.1	Setting the Lift Parameters.....	109
7.4.6.2	Setting the Spin Parameters .....	109
7.4.6.3	Setting the Spin Safety Threshold.....	110
7.4.6.4	Calibrating and Measuring the Helium Level.....	111
7.4.6.5	Monitoring the Console and Shim Stack Temperature.....	113
7.5	Additional Test Applications .....	114
<b>8</b>	<b>Pulse Programming.....</b>	<b>119</b>
8.1	General Principle.....	119
8.2	Structure of Pulse Programs .....	119
8.3	Syntax and Examples.....	120
<b>9</b>	<b>Wiring Schedules .....</b>	<b>127</b>
<b>10</b>	<b>Maintenance and Repairs .....</b>	<b>135</b>
<b>11</b>	<b>Cleaning and Disposal .....</b>	<b>137</b>
11.1	Cleaning .....	137
11.2	Disposal.....	137
11.3	Safety .....	137
11.4	Dismantling.....	138
11.5	Disposal Instructions .....	138

<b>12</b>	<b>Technical Specifications.....</b>	<b>141</b>
<b>13</b>	<b>Contact.....</b>	<b>145</b>
<b>A</b>	<b>Appendix.....</b>	<b>147</b>
A.1	Warning Signs.....	147
A.2	Figures.....	149
A.3	Tables.....	151
A.4	Index.....	153

# 1 About

## 1.1 This Manual

---

This manual is intended to be a reference guide for Bruker certified service engineers. It provides detailed information about the installation, maintenance and service and overall use of the Bruker device.

The figures shown in this manual are designed to be general and informative and may not represent the specific Bruker model, component or software/firmware version you are working with. Options and accessories may or may not be illustrated in each figure.

**Carefully read all relevant chapters before working on the device!**

This manual describes parts and procedures relevant to the device version it is delivered with. For older hardware, please refer to the manual supplied at the time.

## 1.2 Policy Statement

---

It is the policy of Bruker to improve products as new techniques and components become available. Bruker reserves the right to change specifications at any time.

Every effort has been made to avoid errors in text and figure presentation in this publication. In order to produce useful and appropriate documentation, we welcome your comments on this publication. Support engineers are advised to regularly check with Bruker for updated information.

Bruker is committed to providing customers with inventive, high quality products and services that are environmentally sound.

## 1.3 Symbols and Conventions

---

Safety instructions in this manual are marked with symbols. The safety instructions are introduced using indicative words which express the extent of the hazard.

In order to avoid accidents, personal injury or damage to property, always observe safety instructions and proceed with care.



**! DANGER**

This combination of symbol and signal word indicates an immediately hazardous situation which could result in death or serious injury unless avoided.



## **WARNING**

This combination of symbol and signal word indicates a potentially hazardous situation which could result in death or serious injury unless avoided.



## **CAUTION**

This combination of symbol and signal word indicates a possibly hazardous situation which could result in minor or slight injury unless avoided.

## **NOTICE**

This combination of symbol and signal word indicates a possibly hazardous situation which could result in damage to property or the environment unless avoided.

- 
- i** This symbol highlights useful tips and recommendations as well as information designed to ensure efficient and smooth operation.
-

## 2 Introduction

This service manual is intended to be used by trained Bruker service staff only. The manual is a service and installation guide for the console part of the Fourier 300 system. Please refer to the individual probe and magnet manuals for service related information on these devices.

### 2.1 Concept

---

The Fourier 300 is a complete spectrometer for routine and educational NMR. It delivers powerful performance at extremely compact size, low weight and minimized cost. With its new robust probe technology and a unique push-button, power on/off concept, ease of siting and handling is guaranteed.

The Fourier 300 console consisting of:

- Fourier 300 Console
- NMR Probe
- Magnet
- BOSS1 Shim System



Figure 2.1 The Bruker Fourier 300 System

## 2.2 Limitation of Liability

---

All specifications and instructions in this manual have been compiled taking account of applicable standards and regulations, the current state of technology and the experience and insights we have gained over the years.

The manufacturer accepts no liability for damage due to:

- Failure to observe this manual
- Improper use
- Deployment of untrained personnel
- Unauthorized modifications
- Technical modifications
- Use of unauthorized spare parts

The actual scope of supply may differ from the explanations and depictions in this manual in the case of special designs, take-up of additional ordering options, or as a result of the latest technical modifications.

The undertakings agreed in the supply contract as well as the manufacturer's Terms and Conditions and Terms of Delivery and the legal regulations applicable at the time of conclusion of the contract shall apply.

## 2.3 Before you begin

---

This service manual contains information and safety information that are necessary for the installation and servicing of the device.

All maintenance and repairs are to be accomplished using the information in this manual. At the same time references over general maintenance and care from the User Manual are also to be followed.

Consider all safety references!

Be sure that no NMR measurement is in progress during the installation as it might be disturbed.

Information for ordering spare parts is available in the spare parts section from the Bruker Service Center (see ["Contact" on page 145](#)).

## 2.4 Minimum Qualifications for Service Personnel

Type of Task	Personnel	Training and Experience
Transportation	No special requirements.	No special.
Installation	Bruker certified personnel only.	Technically skilled, with a good knowledge of the application field.
Routine Use	Appropriately certified and experienced personnel, familiar with use of computers and automation in general	Laboratory technicians or equivalent. Training is usually done in-house. Familiar with MS Windows® environment.
Daily Maintenance		
Setup and optimization of program	Bruker certified personnel only.	Experienced laboratory technician. High degree of knowledge of the relevant application field.
Preventive Maintenance	Bruker certified personnel only.	Technically skilled with a basic understanding of the application.
Servicing	Bruker certified personnel only.	Background and experience in electronics/mechanics with computer knowledge.

Table 2.1 Overview Installation and Operation Requirements for Personnel

## 2.5 The Bruker Service

Our customer service division is available to provide technical information. See ["Contact" on page 145](#) for contact details.

In addition, our employees are always interested in acquiring new information and experience gained from practical application; such information and experience may help improve our products.

## 2.6 Transport to Manufacturer

When the device must be returned to the manufacturer for a major repair, use the original packaging for transportation.

Include a good description of the problem.



# 3 Safety

This section provides an overview of all the main safety aspects involved in ensuring optimal personnel protection and safe and smooth operation.

Non-compliance with the action guidelines and safety instructions contained in this manual may result in serious hazards.

Read the following safety instructions carefully before you start installation or working with the device.

## 3.1 General

---

Before you start any repair inside of the device, be aware of high voltages 230/115V. Even if these voltages are protected by security features to avoid any contact with your body, it is still possible that you unintentionally touch these voltages with a tool, e.g. screwdriver etc.

Therefore, always check if you really need the power supply to be switched on during your work. Otherwise turn the device off and disconnect the power cable from the wall socket to the device. Avoid that anyone can re-power the system without your notice.

## 3.2 Personnel Requirements

---

### 3.2.1 Qualifications

---

**i** Note: Only trained Bruker personnel are allowed to mount, retrofit, repair, adjust and dismantle the unit!

---

## 3.2.2 Unauthorized Persons

---



### **WARNING**

#### **Risk to life for unauthorized personnel due to hazards in the danger and working zone!**

Unauthorized personnel who do not meet the requirements described in this manual will not be familiar with the dangers in the working zone. Therefore, unauthorized persons face the risk of serious injury or death.

- ▶ Unauthorized persons must be kept away from the danger and working zone.
- ▶ If in doubt, address the persons in question and ask them to leave the danger and working zone.
- ▶ Cease work while unauthorized persons are in the danger and working zone.

## 3.3 Personal Protective Equipment

---

Personal protective equipment is used to protect the personnel from dangers which could affect their safety or health while working.

The personnel must wear personal protective equipment while carrying out the different operations at and with the device.

This equipment will be defined by the head of laboratory. Always comply with the instructions governing personal protective equipment posted in the work area.

## 3.4 Basic Dangers

---

The following section specifies residual risks which may result from using the device and have been established by means of a risk assessment.

In order to minimize health hazards and avoid dangerous situations, follow the safety instructions specified here as well as in the following chapters of this manual.

### 3.4.1 General Workplace Dangers

---

#### Dirt and Scattered Objects

#### CAUTION



#### **Danger of injury from tripping over dirt and scattered objects!**

Dirt and scattered objects may cause people to slip or trip. A fall may result in injuries.

- ▶ Always keep the work area clean.
- ▶ Remove objects which are no longer required from the work area and particularly from the floor.
- ▶ Indicate unavoidable hazards using marking tape.

#### Working in Heights

#### CAUTION



#### **Accident hazard from falling from ladder!**

It is possible to fall from a ladder when it is used to reach the device on some magnets.

- ▶ Do not use a ladder.
- ▶ Use an approved platform to reach the device on the magnet.
- ▶ Wear non-slip shoes.

#### Software Error

#### **NOTICE**

#### **Material damage due to a software error!**

Samples or device may be damaged due to a software error causing malfunction of the control system. Users may also be shocked by abrupt malfunction or unexpected system start.

- ▶ Dummy samples must be used during installation and service.
- ▶ Personnel should be alerted to unexpected malfunctions.

## Impacting Magnet

### NOTICE

#### Material damage hazard due to impacting the magnet!

Impacting the magnet may result in a quench.

- ▶ Mount the device carefully on the magnet.
- ▶ Avoid banging the magnet during installation and operation, e.g. when replacing the sample cassette.

## Genuine Samples

### NOTICE

#### Material damage due to the use of genuine samples during installation and maintenance!

Using genuine samples during installation and maintenance may result in material damage.

- ▶ Use only dummy samples during installation and maintenance.

## 3.4.2 Dangers from Electric Power

---

### Stored Charges

### DANGER



#### Danger to life from stored charges!

Electric charges may be stored in electrical components even after the system has been switched off and disconnected from the power supply. Contact with these components may result in serious or fatal injury.

- ▶ Before working on the specified components, ensure that they have been completely disconnected from the power supply. Allow 10 minutes to elapse in order to ensure that the internal capacitors have been fully discharged.

## Electric Current

### WARNING



#### **Electrical hazard from electrical shock!**

A life threatening shock may result when the housing is open during operation.

- ▶ Disconnect the device from the electrical power supply before opening the device. Use a voltmeter to verify that the device is not under power!
- ▶ Be sure that the power supply cannot be reconnected without notice.

## Residual Electrostatic Potentials

### WARNING



#### **Danger to life from residual electrostatic potentials!**

Friction between material being conveyed may result in significant development of electrostatic potential. Contact with parts immediately following the conveying operation may therefore be life-threatening.

- ▶ Therefore, potential equalisation must be ensured before making contact with parts, unless such equalisation is provided by the customer.

## Electrostatic Discharge



---

Electrostatic discharge from friction may occur, resulting in an electric spark and loud bang. Use ESD flooring and wear ESD shoes.

---

## 3.4.3 Mechanical Dangers

---

### Moving Parts



#### CAUTION

##### **Accident hazard from movement of mechanical parts!**

The fingers or hand may be pinched due to movement of mechanical parts.

- ▶ Shut off the device before accessing.

### Falling Objects



#### CAUTION

##### **Accident and material damage hazard from falling objects!**

Equipment may fall down during assembly, retrofitting, or dismantling. This may result in personal injury or equipment damage.

- ▶ If necessary, assemble/disassemble the device in multiple parts.
- ▶ Use a platform with railings instead of a ladder to reach the assembly area.
- ▶ Avoid working over the head. When this can not be avoided, wear a protective hard hat.
- ▶ Follow the mounting instructions in the installation manual.

### 3.4.4 Dangers from Gases Under Pressure

---

#### Pneumatics



#### WARNING

##### **Danger of injury due to movements caused by stored pneumatic forces!**

Pneumatically driven components may move unexpectedly due to stored residual forces, causing serious injuries.

- ▶ Work on the pneumatics system must only be carried out by trained pneumatics technicians.
- ▶ Before starting work on the pneumatics system, ensure that it has been completely depressurised. The pressure accumulator must be completely relieved.

#### Suffocation



#### WARNING

##### **Accident hazard from asphyxiation!**

A break in the pneumatic hose may result in the uncontrolled exit of nitrogen into the laboratory.

- ▶ An oxygen warning device should be present in the laboratory if the device is operated with nitrogen.
- ▶ Note that leakage from the main supply line cannot be stopped by the device Lite!

## 3.4.5 Dangers from Radiation

---

### Strong Magnetic Fields

#### **WARNING**

##### **Danger to life from strong magnetic fields!**

Strong magnetic fields may cause serious injuries or death and significant damage to property.

- ▶ Persons fitted with heart pacemakers must be kept away from the appliance. The functionality of the heart pacemaker could be compromised.
- ▶ Persons with metal implants must be kept away from the appliance. Implants may heat up or be subject to magnetic attraction.
- ▶ Ferromagnetic materials and electromagnets must be kept away from the magnetic source. Such materials could be subject to magnetic attraction and may fly around the room, injuring or killing people. Minimum distance 3 meters.
- ▶ Remove magnetic items (jewelry, watches, pens etc.) before carrying out maintenance work.
- ▶ Keep electronic equipment away from the magnetic source. Such equipment could be damaged.
- ▶ Keep storage media, credit cards etc. away from the magnetic source. Data could be erased.



---

**i** Note: The magnetic field of the device does not cause any personal injuries or property damage. For further information see the manual of the magnet used.

---

### 3.4.6 Dangers Due to High or Low Temperatures

---

#### Hot or Cold Surfaces



#### **CAUTION**

**Accident hazard from contact with hot or cold surfaces on the unit.**

Contact with the hot or cold surfaces of the unit may result in serious burns.

- ▶ Do not touch device parts of cooled or heated units.
- ▶ Do not use damaged samples.
- ▶ After removing a sample or cassette allow it to cool or thaw before coming in contact.

#### Thermal Shock

#### **NOTICE**

**Material damage hazard from overflow of cryogenics.**

Material damage may result from the overflow of cryogenics.

- ▶ Turn off the device during magnet servicing.
- ▶ Cover the device with a protective cover, e.g. P/N 1804420 provided in the accessory case, to avoid contact with cold gases.
- ▶ Be sure to use sufficient transfer line and Teflon evacuation hose for nitrogen and helium refills based on recommendations in the magnet manual.
- ▶ After refilling cryogenics some parts of the magnet may be icy. Be sure to remove the ice to avoid its melting onto the device.

## 3.4.7 Danger from Chemical Substances

---

### NMR Solvents

#### NOTICE

##### **Material damage hazard from material contact with NMR solvents!**

Material damage may result when the device comes in contact with NMR solvents.

- ▶ Follow instructions provided in the manual for correct handling of solvents.
- ▶ Follow the sensor cleaning procedures described in this manual.
- ▶ If surface damage should occur, contact Bruker for repair of damaged parts.

### Safety Devices

#### ⚠ WARNING



##### **Danger to life from nonfunctional safety devices!**

If safety devices are not functioning or are disabled, there is a danger of serious injury or death.

- ▶ Check that all safety devices are fully functional and correctly installed before starting work.
- ▶ Never disable or bypass safety devices.
- ▶ Ensure that all safety devices are always accessible.

### Protective Earth Conductor

#### ⚠ WARNING



##### **Danger to life from contact voltage!**

Absent or faulty protective earth conductor may result in contact voltage. This may pose a risk of injury or death.

- ▶ Before the initial commissioning of the appliance, connect the main power supply to the socket and verify the complete functionality of the protective earth conductor.

### Overpressure Valve

The high pressure system includes an overpressure valve which safely reduces the excess pressure in the event of inadmissible pressure conditions developing as a result of faulty operation, component failure or other irregular events.

## 3.5 Environmental Protection

---

### **NOTICE**

#### **Danger to the environment from incorrect handling of pollutants!**

Incorrect handling of pollutants, particularly incorrect waste disposal, may cause serious damage to the environment.

- ▶ Always observe the instructions below regarding handling and disposal of pollutants.
- ▶ Take the appropriate actions immediately if pollutants escape accidentally into the environment. If in doubt, inform the responsible municipal authorities about the damage and ask about the appropriate actions to be taken.

The following pollutants are used:

<b>Helium inert gas</b>	Helium inert gas may cause suffocation at high concentrations. Disposal of the empty gas cylinders must be performed by a specialist disposal company.
<b>Nitrogen gas</b>	Nitrogen gas may cause suffocation at high concentrations. Disposal of the empty gas cylinders must be performed by a specialist disposal company.
<b>Coolants</b>	When released, coolants develop decomposition products which are hazardous to the environment. Maximum care and caution are required when handling coolants. Always observe the safety data sheet issued by the manufacturer. Ensure that personnel handling coolants are regularly informed about potential dangers and are instructed in the safe handling of coolants.
<b>Cleaning liquids</b>	Cleaning liquids incorporating solvents contain toxic substances. They must not be allowed to escape into the environment. Disposal must be carried out by a specialist disposal company.

## 3.6 Signage

The following symbols and information signs can be found in the work area. They refer to their immediate surroundings.

---

**i** Note: The identification and placement of warning labels are included in the manual. The laboratory supervisor is responsible for ensuring that all the warning labels are maintained in their proper place any time that the device is used.

---

### Electrical Voltage



Only qualified electricians are permitted to work in a work room marked by this sign. unauthorized persons must not enter the workplaces thus marked and must not open the marked cabinet.

## Danger Spot



Warning indicating a danger spot in work rooms.

## Hand Injury



Keep hands away from areas bearing this warning sign. There is a danger that hands could be crushed, drawn in or otherwise injured.

## Maximum Sample Height



There is a danger that the sample breaks, if the sample exceeds the maximum sample height.

## 3.7 Spare Parts

---

### **i** Loss of guarantee

If non-approved spare parts are used the manufacturer's guarantee is invalidated.

---

Purchase spare parts from authorised dealers or directly from the manufacturer. See ["Contact" on page 145](#) for manufacturer's address.



## 4 Tool Requirements

All tools required for the installation are provided in the accessory case.

---

**i** Be sure to use non-magnetic tools, especially when working on unshielded magnets.

---



# 5 Design and Function

## 5.1 Overview

---



Figure 5.1 The Fourier 300 Console

## 5.2 Brief Description

---

The Fourier 300 Console consists of the following main components:

- "Intelligent Devices with Ethernet"
- "Intelligent Devices with Can-Bus"
- "Intelligent Devices with LVDS"
- "Devices without Interface"

The following block diagram shows how all the components work together:

# Design and Function

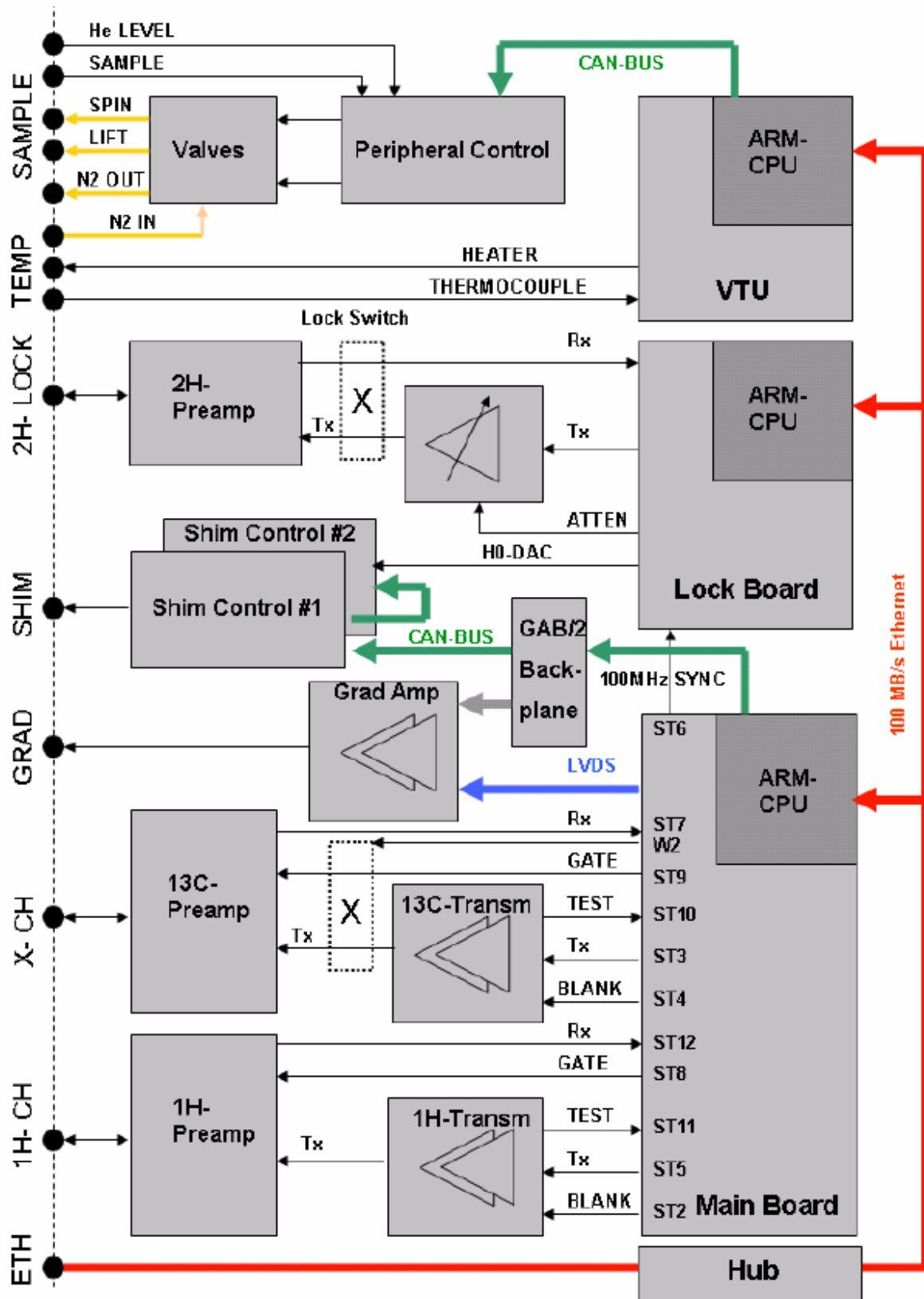

Figure 5.2 Fourier 300 Console Overview

## 5.2.1 Internal Console Component Layout

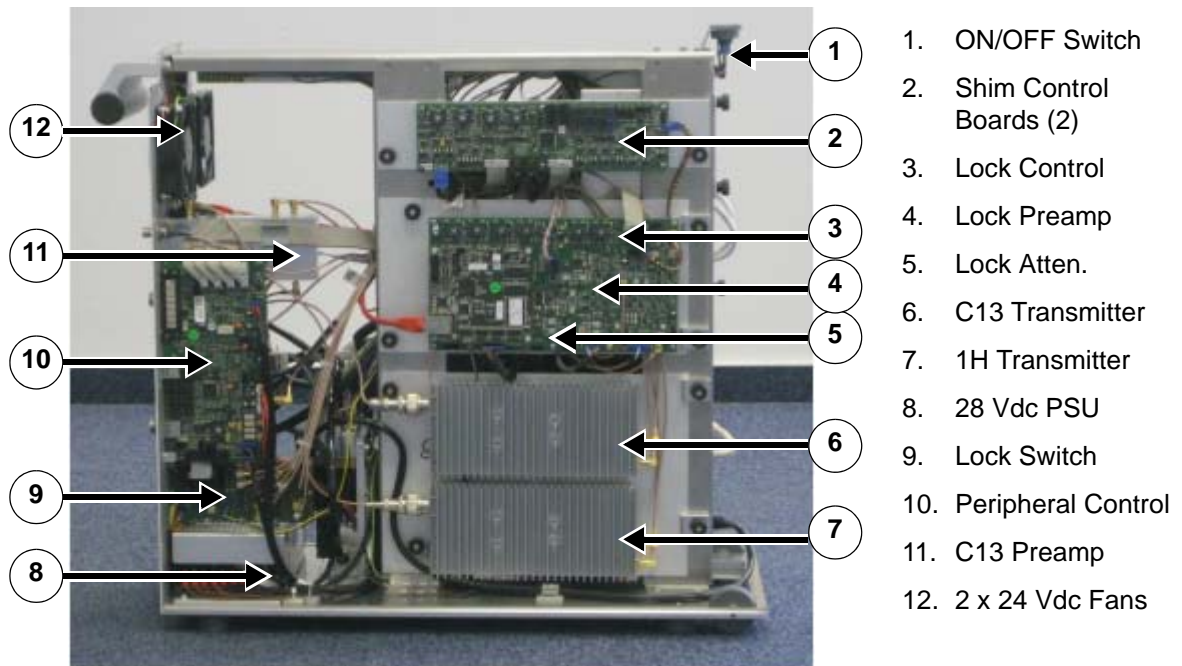

Figure 5.3 Console: Left Side

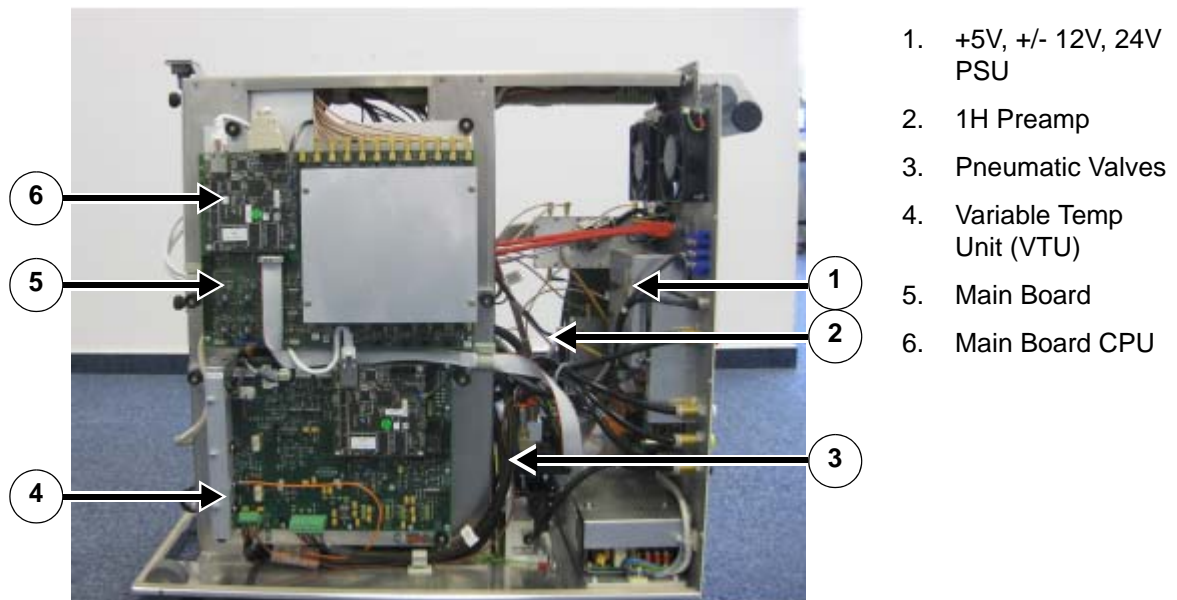

Figure 5.4 Console: Right Side

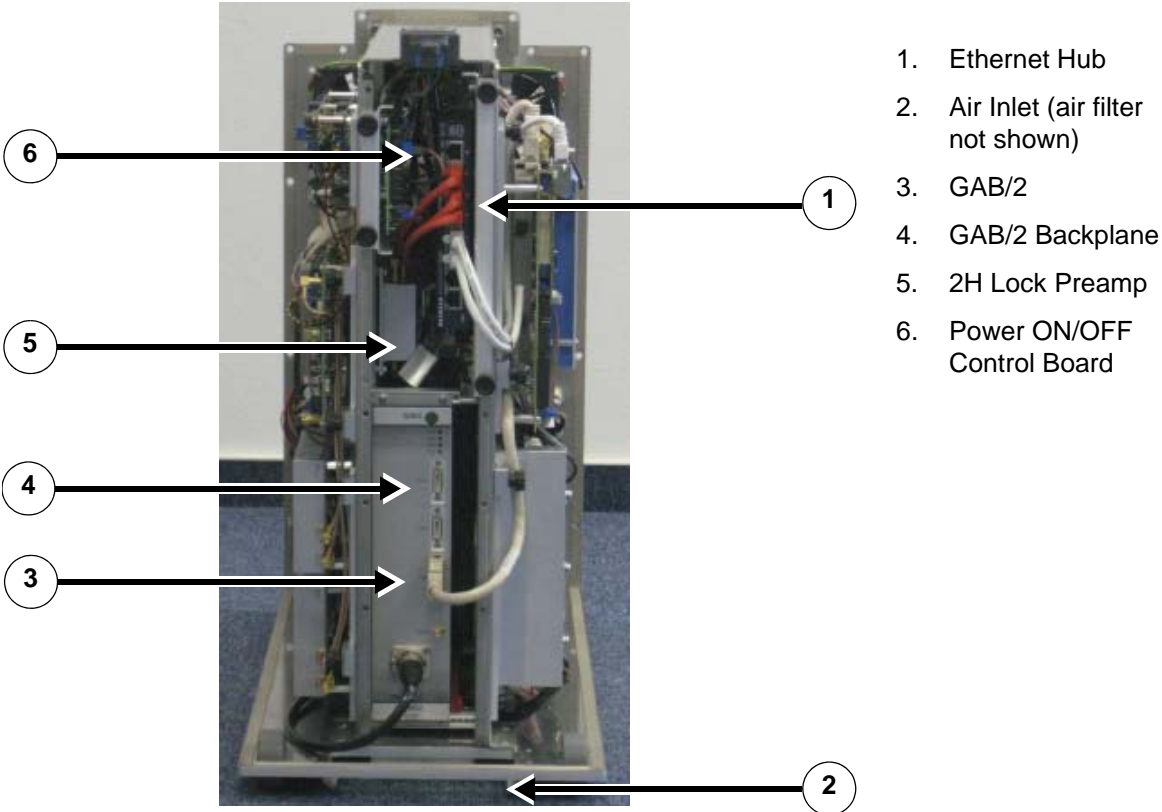

Figure 5.5 Console: Front View

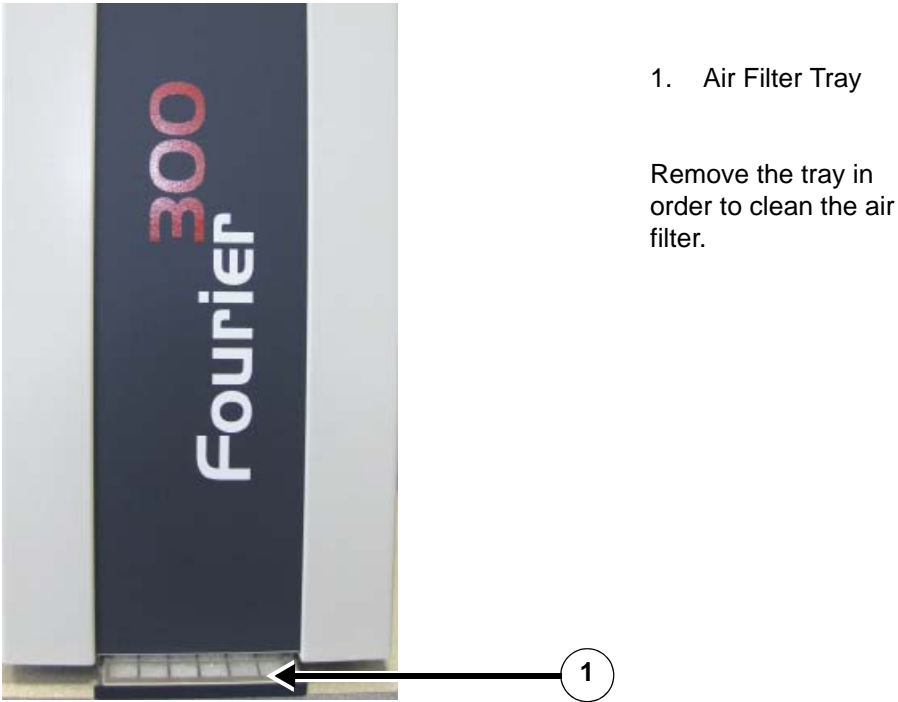

Figure 5.6 Location of the Console Air Filter Tray

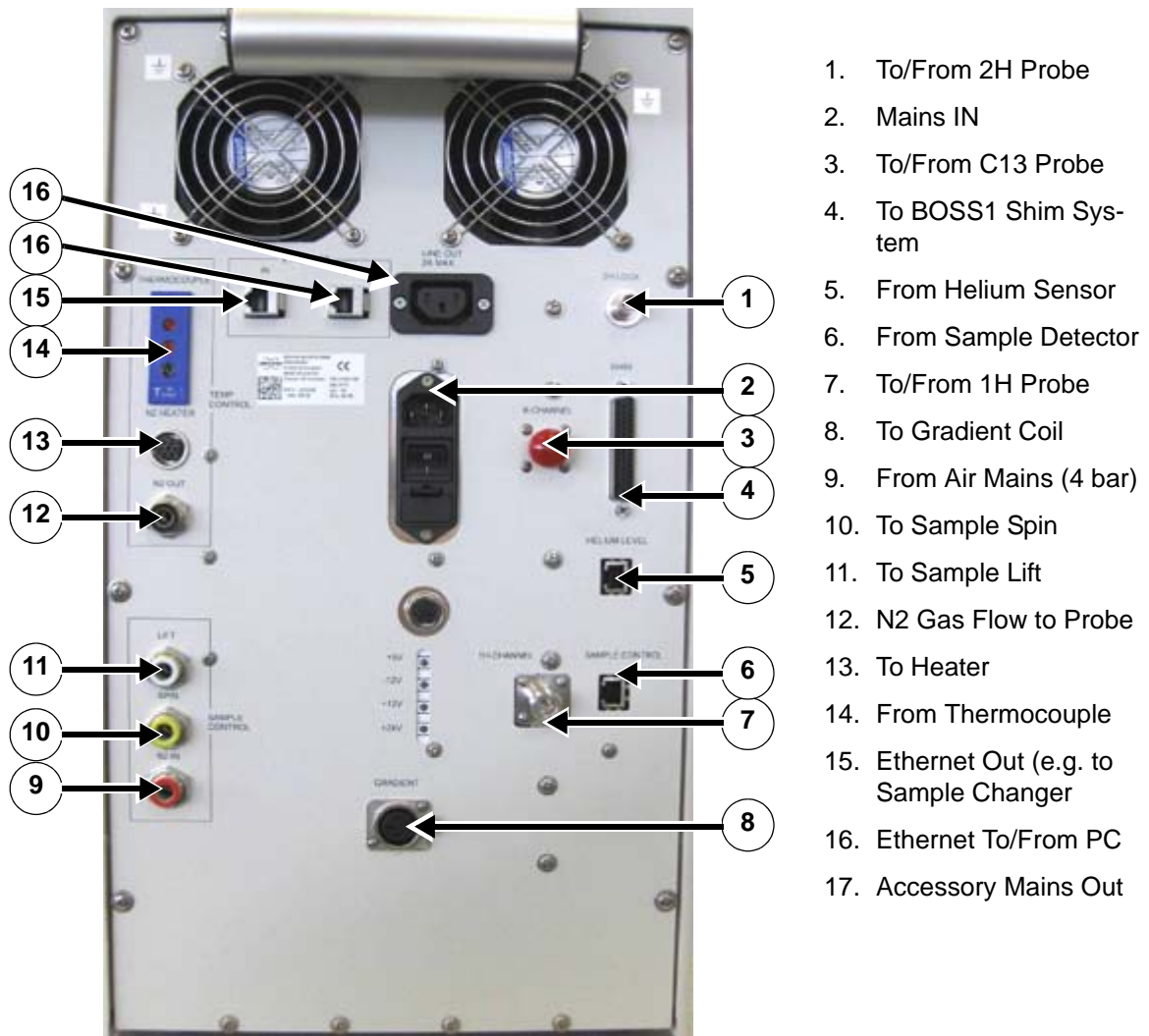

Figure 5.7 Console Input and Output Connections

## 5.3 Unit Descriptions

### 5.3.1 Intelligent Devices with Ethernet

The intelligent devices with Ethernet connectors are connected to the Front End PC via the built-in hub. These devices include:

- Main Board (Pulse Programmer, 1H Modulator, C13-Modulator, Receiver, Digital Filter)
- Lock System (Digital 2H Lock, including Preamplifier and power attenuator)
- VTU (Variable Temperature Unit for N2 Sample Temperature Control)

## 5.3.1.1 Main Board

The Main Board contains the Pulse generation for two RF channels, the Receiver Channel including digital filtering and and Gradient Channel with LVDS Interface.

The Pulse Programmer is preloaded with a complete 1D- or 2D-Experiment. Once started, the entire experiment is run from the FPGA without interaction from the CPU. There is an external trigger that can be used to trigger individual scans.

The receiver uses a direct sampling technique to digitize and downconvert the RF signal. The FPGA contains a DSP core which performs the digital filtering down the final required spectral bandwidth. The data from each single FID is stored in the FPGAs internal memory. Accumulation of FIDs is performed by the on board Arm CPU , which then transfers the data to the front end whenever it is requested.

The main board has a fixed transmit but a variable receiver routing.

DDS2 is equivalent to FCU2 in the signal routing table and is dedicated to 1H.

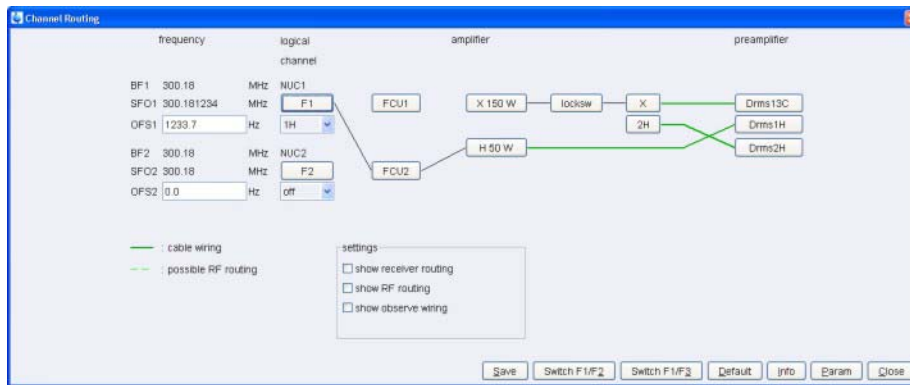

Figure 5.8 DDS2

DDS1 is equivalent to FCU1 in the signal routing table and is dedicated to C13.

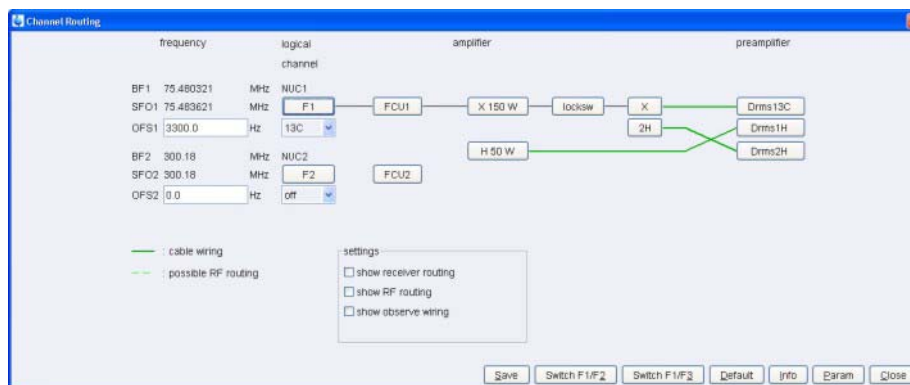

Figure 5.9 DDS1

The Main Board is also the Can-Bus Master for the shim Control and the GAB/2 Back-

plane.

The main board receives only 28Vdc from the central 28V PSU and generates all the other voltages it requires on board.

### 5.3.1.2 Lock System

---

The Lock System comprises three unit that are mounted together on one module:

- Lock-Board (transmit and receive)
- Lock Power Attenuator
- 2H Preamplifier

The lock board generates continuous small flip angle pulses at nominal 1 kHz rate. The lock transmit power can be varied in the range from 0dBm to -30 dBm using the separate digital attenuator. The receiver used a 50 MHz ADC to digitally down-convert the FID using the same principle as on the main board. The thus obtained real part of the FID is then used for the lock monitor, whereas the imaginary part is used to track the field, using a digital P+I control.

The lock operates on a field locking principle, using the H0 Coil of the BOSS1 Shim System. The total range of the lock is around 20 kHz (as measured on 1H). This is controlled by a 12-bit coarse DAC for range selection and a 12-bit fine DAC which does the actual field regulation. The resolution of the fine DAC is about 0.025 Hz per DAC Step. In case of magnet drift, the system has an “auto-range” function. i.e. when the fine DAC gets to below 500 or above 3500, the coarse DAC is incremented or decremented by one step, to bring the fine DAC back nearer the center of its operating region.

The two DAC voltages are fed to the shim board where they are scaled and added. A current driver provides the driver current for the H0 coil.

The Lock board receives only 28Vdc from the central 28V PSU and generates all the other voltages it requires on board.

### 5.3.1.3 Variable Temperature Unit (VTU)

---

The VTU is uses to control the sample temperature. The heater and thermocouple connections are fully compatible with the BVT3000. It supports Thermocouple Types T and K but unlike the BVT3000 it has an internal electronic cold junction compensation, which means that ambient temperature variations do not affect the reading. The gas flow regulation is done using 4 digital valves which allow 16 gas flow settings from 0 to 2000/h. The recommended gas flow for the Fourier “one for all” probe is between 670 and 800 l/h. For setting PID values please refer to the VTU web server description.

## 5.3.2 Intelligent Devices with Can-Bus

---

- 2 x Shim Boards (12 Channels each + H0 Control) – Slave of Main Board
- Peripheral Control Board (Spin, Lift, Helium Level Control, Sample Status) – Slave of VTU

- GAB/2 Backplane (Interface to GAB/2 Board and -24V power Supply) Slave of Main Board

## 5.3.2.1 Shim Control

The Shim Control comprises two shim boards, each of which is capable of controlling up to 12 channels and a H0 coil. The two boards are cascaded and controlled from the **main board** CPU via CAN-Bus. Each channel has a 16-bit DAC and can deliver up to 300 mA. The shim board has an ADC with a multiplexer which can measure the current flowing through each coil for diagnostic purposes. Please refer to the web server description for details.

The shim currents are fed to the peripheral control board via 4 ribbon cables (2-per board) where they are converted to the standard BOSS1 Connector.

The 20 shim terms are divided up between two shim boards:

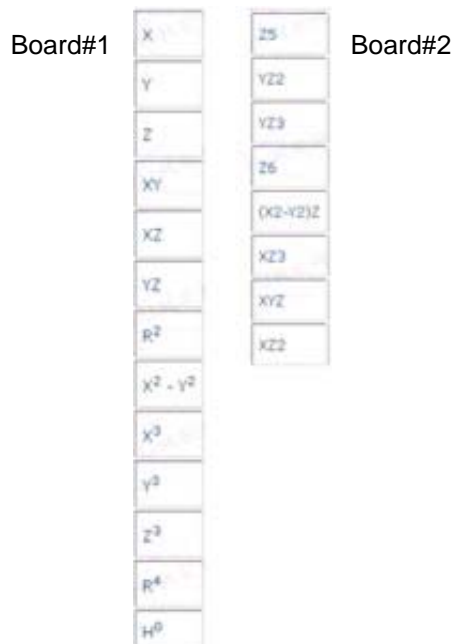

Figure 5.10 Two Shim Boards

The shim control boards are identical in build. The definition as to whether a board is shim board #1 or #2 is done via a jumper connector which is plugged into ST11. If this connector is present, it becomes board #2. This is also shown by LED “LD7” which is then lit.

Since shim board #1 also controls the H0 current, it has a connection to the Lock Board, where the lock control voltage is generated.

The shim boards receive only 28Vdc from the central 28V PSU and generate all the other voltages they requires on board.

## 5.3.2.2 Peripheral Control Board

---

The peripheral control board takes care of spin, lift, sample control, helium level measurement and also routes the individual shim cables to a standards BOSS1-Connector. It is controlled via CAN-BUS from the **VTU**. It also contains temperature sensors to monitor the console and shim stack temperatures. Spin and Lift are controlled using proportional pneumatic valves that require a PWM (pulse width modulation) to set the required airflow. Please refer to the VTU web server description on how to set up the optimal air flow settings for spin and lift, as well as how to calibrate the helium level sensor.

## 5.3.2.3 GAB/2 Backplane

---

The GAB Backplane provides the GAB/2 Gradient Amplifier with all the necessary infrastructure to initialize and calibrate the GAB/2 gradient amplifier, i.e. it performs the function normally carries out by the ELCB Board. It also contains a DC/DC converter to provide the -24VDC which are otherwise not present in the console. It is controlled via CAN-Bus from the **main board** and has an additional slot for an optional ELCB Board for debug purposes.

The actual control of the gradient information is done via the LVDS interface from the main board.

## 5.3.3 Intelligent Devices with LVDS

---

- GAB/2 Gradient Amplifier

## 5.3.4 Devices without Interface

---

- 2 x Transmitters (1H & C13-Channel)
- 1H Preamplifier
- C13 Preamplifier
- Lock Switch (to route C13 Transmitter and Preamp to 2H Lock Coil for gradient shimming purposes)
- $\pm 5V$ , 12V & 24V Power Supply (used for VTU, Preamps and Ethernet switch)
- 28 V Power Supply (used for everything else)
- 2 x Ventilators

## 5.3.4.1 Transmitters

There are two transmitters which are identical in build but have a fixed routing so that the upper one is dedicated to 1H (providing about 50W at 300 MHz) and the other is dedicated to C13 (providing about 150W at 75 MHz). The transmitters receive their RF and gating inputs from the main board and have an RF-Output monitor which can be routed to the main board receiver for diagnostic purposes.

The Transmitters receive only 28Vdc from the central 28V PSU. The gating inputs on both transmitters are active high TTL.

## 5.3.4.2 Preamplifiers

There are three dedicated preamplifiers. The 13C (75 MHz) and 2H (46 MHz) Preamp are of the same type. The 1H (300 MHz) preamp is unique. All preamps have a gain of ca. 40dB.

Each amp has an RFin, RF out and two logic inputs. "Gate" is used to actively gate the preamp for low power pulses that don't have enough voltage to gate themselves. This is a coaxial input and is driven by one of the service pulses on the main board.

"Tune/Blank" is a dual purpose input. It switches the amplifier to "tune" mode, which measures the reflective power and is used for the wobble function. Since this mode also bypasses the 40 dB gain stage, it also blanks the preamp. The software always blanks the preamp that is not being used for observing, to avoid reflected power from decoupling pulses on the other channel getting to the receiver. The tune/gate signal is generated by the main board and is fed to the lock switch via a ribbon cable. From there it routes the tune/gate signal to the individual preamps (see wiring schedule in appendix). LEDs indicate the status of tune/blank mode (see below).

The preamps do not have a separate protection input as they are self-protecting. They receive +12V as a single supply voltage.

Function	Sub-D9	1H	13C / 2H
Tune/Blank	6	Hi	Hi
Gate	SMB	Low	Hi
GND	3;7;8	0V	0V
Vsupply	4;5;9	12V	12V

Table 5.1 Preamplifiers

## 5.3.4.3 Lock Switch

The Lock Switch is required in order to perform gradient shimming on Deuterium for samples that do not contain water. It reroutes the transmit and receive signals from the C13 channel to the 2H coil. For diagnostic purposes 2H observe spectroscopy can be carried out by selecting the 2H observe nucleus.

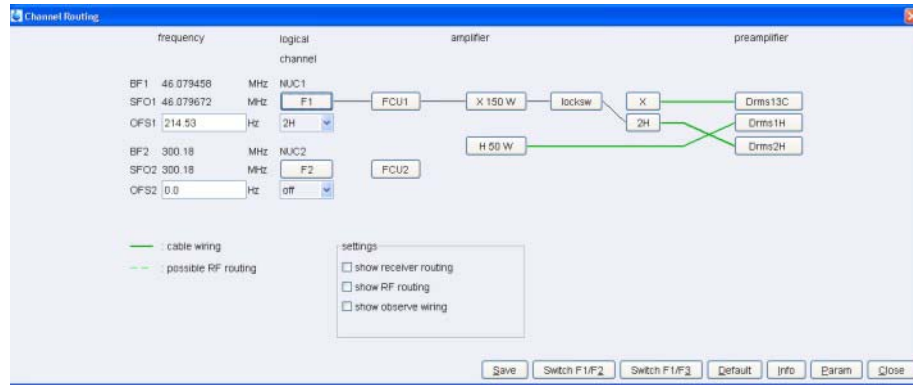

Figure 5.11 Lock Switch

The lock switch signal is generated by the main board and is fed to the lock switch via a ribbon cable. An audible click can be heard when it is activated. A LED also indicates the status of the lock switch - see the figure below.

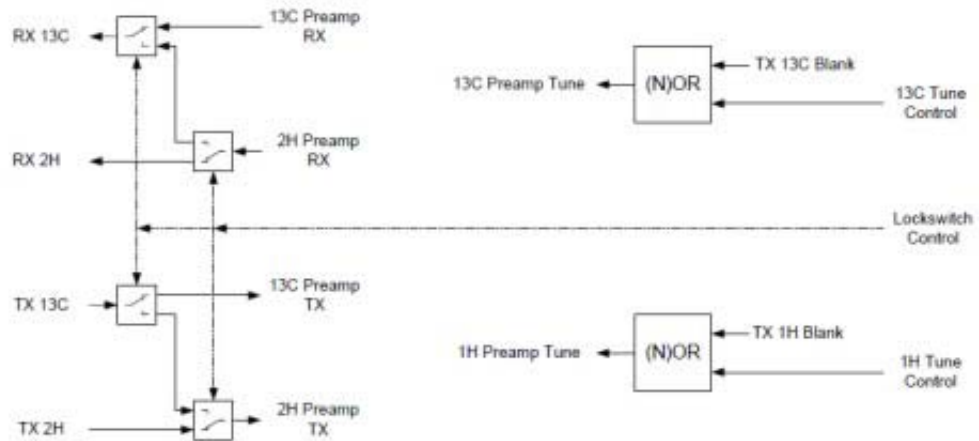

Figure 5.12 Lock Switch Block Diagramm

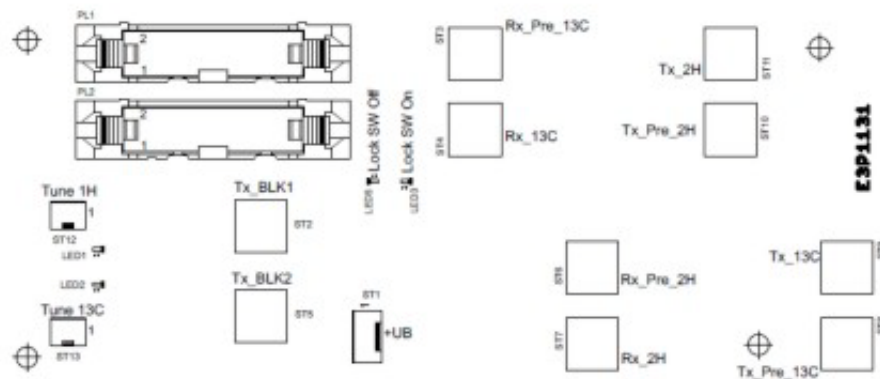

Figure 5.13 Lock Switch connections & LEDs

#### 5.3.4.4 Power Supplies

The Fourier300 Console has two AC power supplies.

- PSU 1: Input 90 – 250 Vac, Output: +5V,  $\pm 12V$  and +24Vdc (+standby voltage)
- VTU
- Fans
- Ethernet Hub
- Preamplifiers

PSU 2: Input 90 – 250 Vac, Output: +28Vdc, 20 A

- Main Board
- Lock Board
- Shim Boards
- Transmitters
- GAB/Backplane

When the mains switch on the rear panel is switched on, the console first goes into stand by which is indicated by a blinking ON/OFF switch. Pressing the ON-OFF Switch then provides both PSU1 and PSU2 via inhibit signals provided by the Power ON/OFF Control Board which is located close to the ON/OFF switch.

PSU1 is fused with 4A slow blowing fuses. The power consumption of the console is approx 300 W.

For details of how the power is distributed to the units see the wiring schedule in the appendix.

## 5.3.4.5 Ventilators

---

Two 24Vdc Ventilators at the rear panel suck out warm air from the console. The ventilators have serial resistors to bring their actual operating voltage down to about 18V, where they operate more silently, prolong ventilator and filter lifetime and still create sufficient air flow.

The fresh air intake is in the base plate near the front of the console. The air filter can be removed for cleaning services without opening the console.



Figure 5.14 Ventilator



## 5.5 Accessories

---

The Fourier has the following accessories / options:

- Sample Express Lite Sample Changer
- BSCU N2 Cooling Unit
- Magnet vibration Isolation



# 6 Installation

## 6.1 Unpacking

---



### WARNING

**Lifting the Fourier up and out of the carton may cause injury and damage the device.**

- ▶ Simply slide the carton sleeve up and over the console, and then slide the console off the pallet.

### NOTICE

**Material damage hazard due to incorrect unpacking procedure!**

Lifting the Fourier console out of the carton may damage the device.

- ▶ Simply slide the carton sleeve up and over the console, and then slide the console off the pallet.
- ▶ The Console has wheels and can be moved around freely using the handle at the back.
- ▶ Retain packaging in case the console has to be sent back for repair/exchange later.

## 6.2 Wiring Up

---

Please refer to the diagram in chapter "[Wiring Schedules](#)" on page 127.

### External Filters

Some older models have three external filters (Z13383, Z14331, Z00116).

- Z13383 is connected to 1H Connector the rear of the console.
- Z14331 is connected to C13 Connector the rear of the console.
- Z00116 is connected to C13 Connector of the probe.

## Newer models just have two external filters (E1451420, E1451430)

- E1451420 is connected to 1H Connector the rear of the console.
- E1451430 is connected to C13 Connector the rear of the console.

## 6.3 Adjusting Air Pressure

---

Adjust the air pressure so that the manometer in the console reads between 3.5 and 4 bar. That way the default spin and lift parameters will get you started.

## 6.4 Switch on for the first time

---

The console has three modes:

- OFF (Blue light OFF), switch at rear panel set to OFF.
- STAND BY (Blue light BLINKING), switch at rear panel set to OFF, ON/OFF Button at top of console not yet pressed.
- ON (Blue light ON).

---

**i** Note: It is IMPORTANT to switch the console on BEFORE switching on the PC, since the console contains the Ethernet hub, and the DHCP Server will not start if it doesn't find a network.

---

## 6.5 Checking that the Console has booted

---

This procedure takes 30-60 seconds, provided the DHCP Server is running. There is no visual indication on the console, but the easiest way to check is to see if the three main Ethernet devices (Main Board, Lock and VTU) can be reached via ping or a web browser. Their addresses will usually be in the range:

**149.236.99.25x**

If you are not sure the DHCP Server is running, you can check by opening  
**Control Panel -> Administrative Tools -> Services -> Bruker DHCP Server**

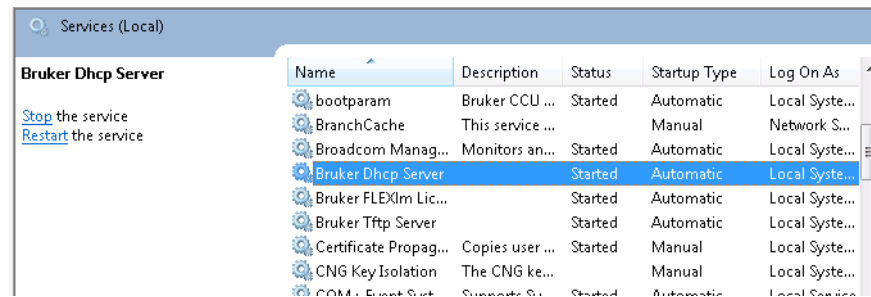

Figure 6.1 Checking the DHCP Server

If you are not sure what addresses have been assigned, you can check by opening the following file

### **Bruker\Diskless\dchpd.leases**

```

lease 149.236.99.254 {
  starts 4 2010/08/19 11:08:55;
  ends 2 2038/01/19 03:14:06;
  tstp 2 2038/01/19 03:14:06;
  binding state active;
  next binding state free;
  hardware ethernet 00:00:ad:11:4f:12;
  uid "\001\000\000\255\0210\022";
}

lease 149.236.99.253 {
  starts 4 2010/08/19 11:08:58;
  ends 2 2038/01/19 03:14:06;
  tstp 2 2038/01/19 03:14:06;
  binding state active;
  next binding state free;
  hardware ethernet 00:00:ad:13:34:12;
  uid "\001\000\000\255\0234\022";
}

lease 149.236.99.252 {
  starts 4 2010/08/19 11:09:01;
  ends 2 2038/01/19 03:14:06;
  tstp 2 2038/01/19 03:14:06;

```

```
binding state active;  
next binding state free;  
hardware ethernet 00:00:ad:12:85:12;  
uid "\001\000\000\255\022\205\022";
```

Once you are sure that all three devices have booted, you can start TopSpin. Normally your PC will come with CF having already been carried out. If you get an error message, that one or more devices cannot be found, you may have to repeat CF.

## 6.6 Performing cf on a Fourier

---

TopSpin 3.1 is the first software to be used with the Avance system and the Fourier system. All changes to TopSpin regarding the new Fourier console are implemented in the same software tree. That means that a Fourier spectrometer can be controlled from any computer running TopSpin 3.1.

As with the Avance systems, the Fourier must be configured in TopSpin using the **cf** command. The NMR administrator password is required to run **cf**.

The first screen allows to edit an already existing configuration or to create a new one.



### 6.6.1 Setting the spectrometer frequency

The next screen asks for the configuration name and spectrometer frequency (1H) in MHz. It is usual for Avance300 systems to set it to 300.13MHz. The field of the magnet is close to the corresponding value and the correct field value is achieved by adding a  $B_0$  shim current to it. The Fourier console works the same way. But in order to keep the  $B_0$  shim current at a low value, the frequency should be set to a value close to the one which originates from the actual field of the respective magnet.

At this point, there is a minor inconsistency which can't be solved. The value of the magnetic field is checked using the NMR console to detect a proton or Deuterium resonance line. That means that it is necessary to run **cf** twice. The first run can be done with the default 1H frequency of 300.13MHz. Without using the lock, one has to search for the 1H spectrum of a suitable sample (Sucrose or Doped Water, use **zg** with a pulse length of about 5 $\mu$ s and a spectrum width of >200kHz). The frequency at which the spectrum is detected, is close enough to the correct value. Choose a rounded value next to it and re-run **cf** with this value.

In the example shown here, the magnet's field resulted it a proton frequency of roughly 300.178MHz. This could be rounded up to 300.18 or down to 300.17, e.g., to have numbers being easy to memorize.

## 6.6.2 ETH Addresses and tty Settings

---

During the cf run, some information is shown about the detected hardware. In addition to the Fourier main board, only the lock system, the VTU and the Lockswitch are part of the basic instrument. The Ethernet addresses of the Lock and the VTU are set by the DHCP server and don't need to be set manually. A missing entry shows that the respective board couldn't be detected. This may indicate a problem of the board or the DHCP server.

The Lockswitch has to be set to amplifier 1, which is the X amplifier.

The preamplifiers and power amplifiers are build-in and are directly controlled by the Fourier main board.

Currently, none of the Avance accessories is used with the Fourier system. This may be done in the future, though.

## 6.6.3 Cortab and Power Check

---

Cortab files for the console are already measured as part of the production. So, please enable power check for probe protection.

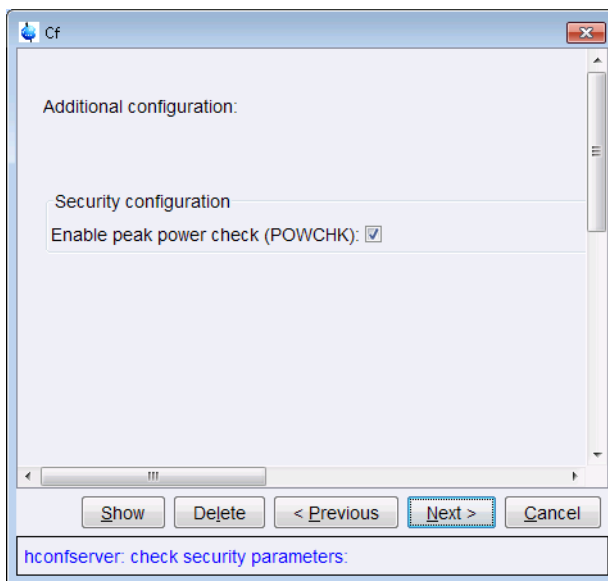

## 6.6.4 Editing the Nuclei List

---

It might be a good idea to edit the nuclei list. The Fourier is a dedicated 1H, 13C and 2H instrument. So, only these nuclei are needed. This is not mandatory but a lot of selection windows are much easier to scroll if the nuclei list has been cut short.

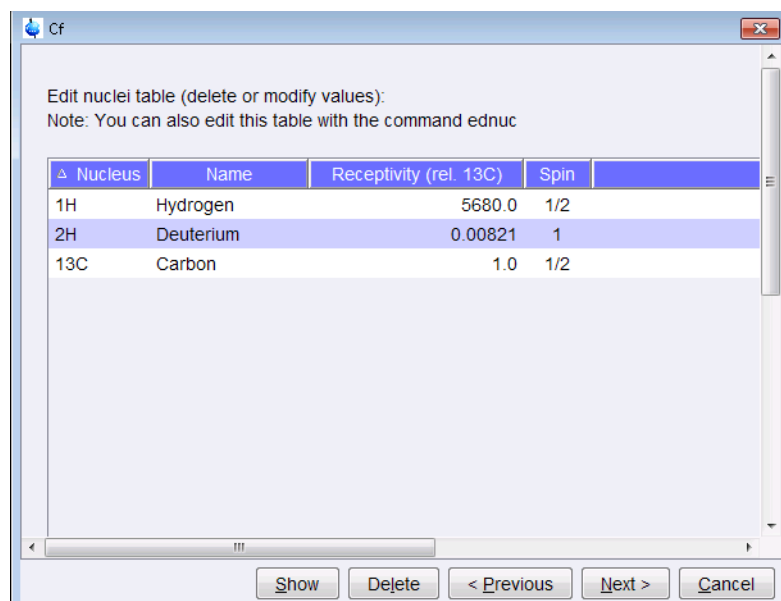

When CF has completed its device search, it comes up with a page of information showing all the devices it found.

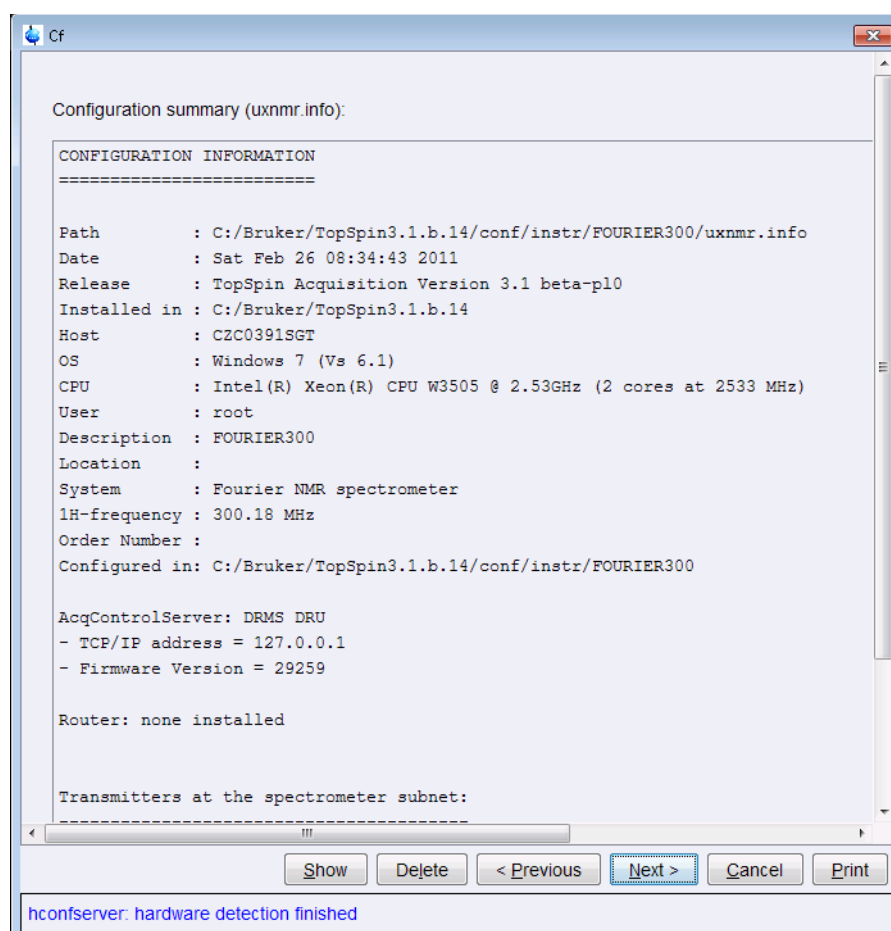

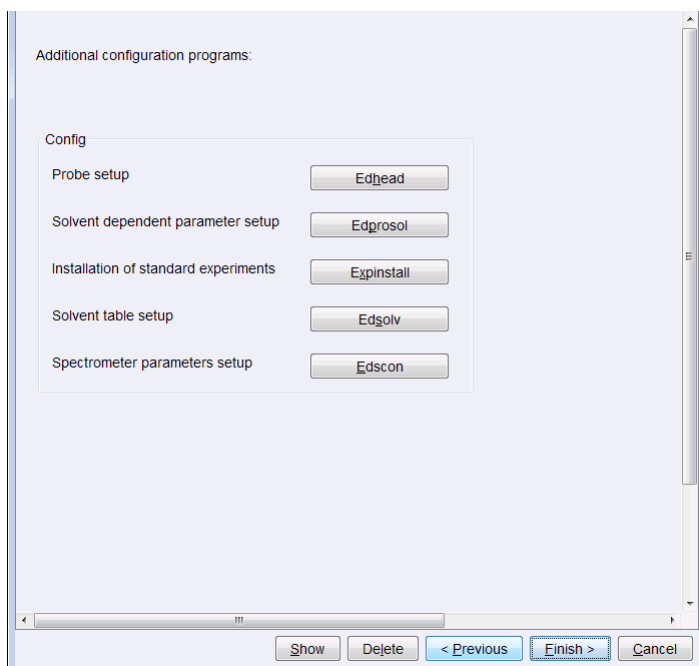

## 6.6.5 RF routing

The routing window is rather easy. The green lines indicating a fixed hardware wiring have to be drawn as shown in the next screenshot.

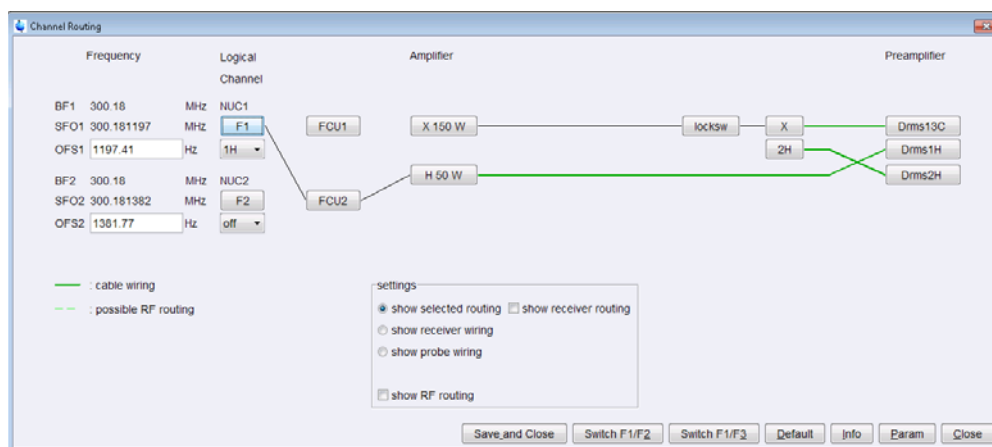

The receiver routing is done automatically and is not shown by default. It can be made visible by clicking on "show receiver routing" and must look like this.

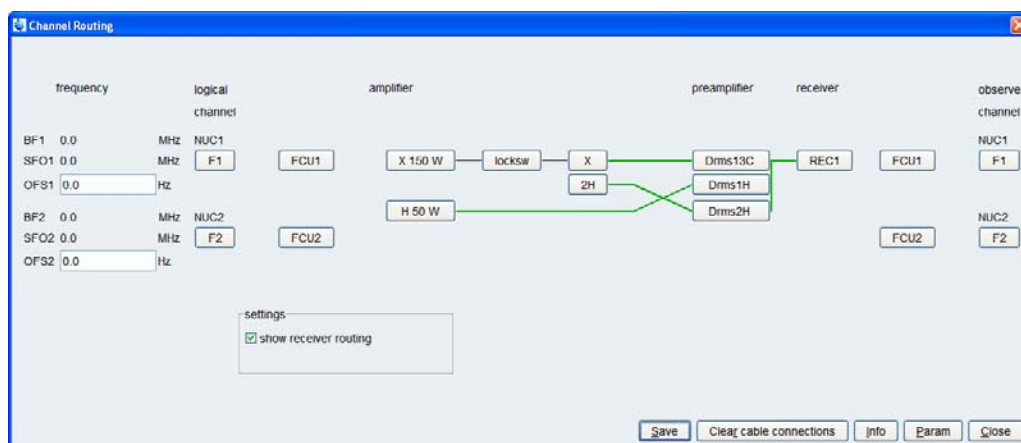

The configuration ends with a summary of all the hardware and settings.

## 6.7 Additional Configurations

After finishing, **cf** automatically opens a window from which additional configurations can be started.

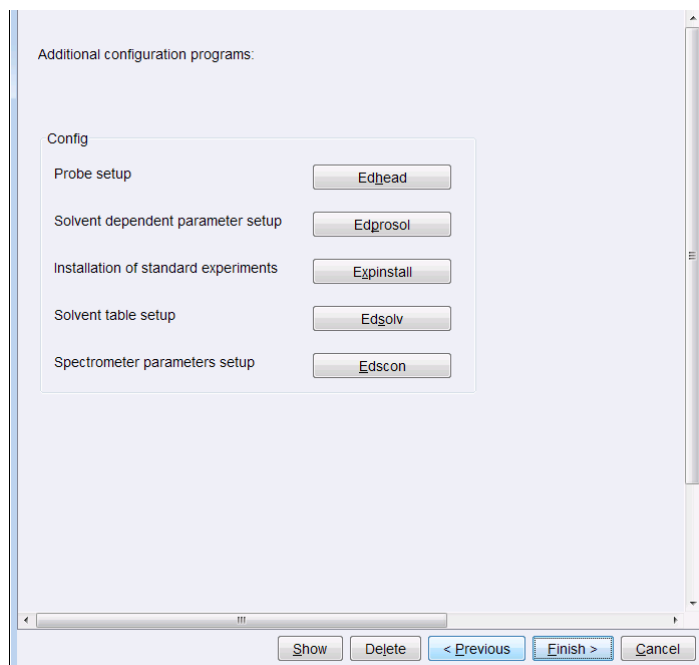

## 6.7.1 Installation of Pulse Programs and Parameter Sets

Clicking on “Expinstall” starts the installation and conversion of pulse programs and datasets. Choose “Installation for Spectrometer”.

The next window will show an entry “Fourier” after finalizing TopSpin 3.1. click on it to install Fourier specific pulse programs and parameter sets.

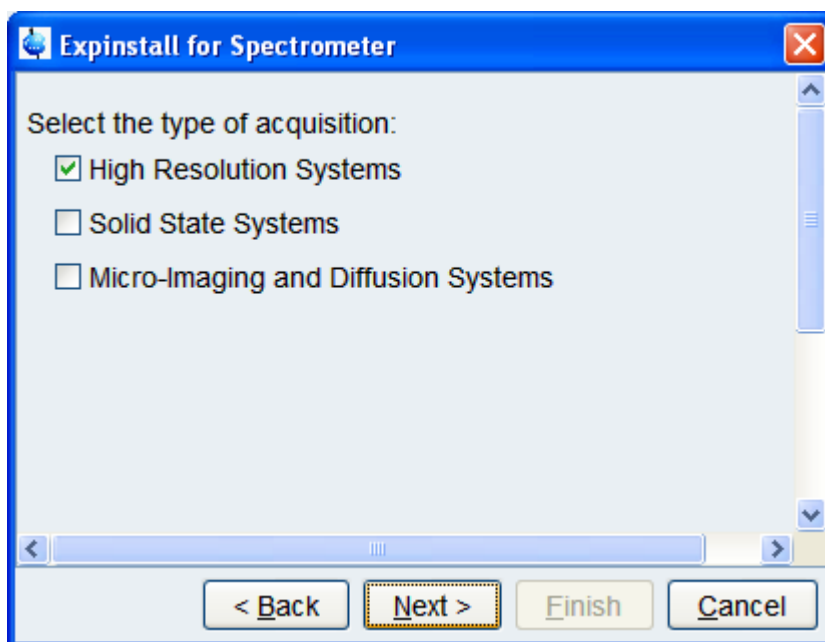

On the following window, one can choose which files should be installed: pulse programs, AU programs, CPD programs, shape files, etc.

Followed by the selection window for printer and plotter.

The last window lets one select the digitizer and default acquisition mode.

**Follow the next few screen shots using default settings:**

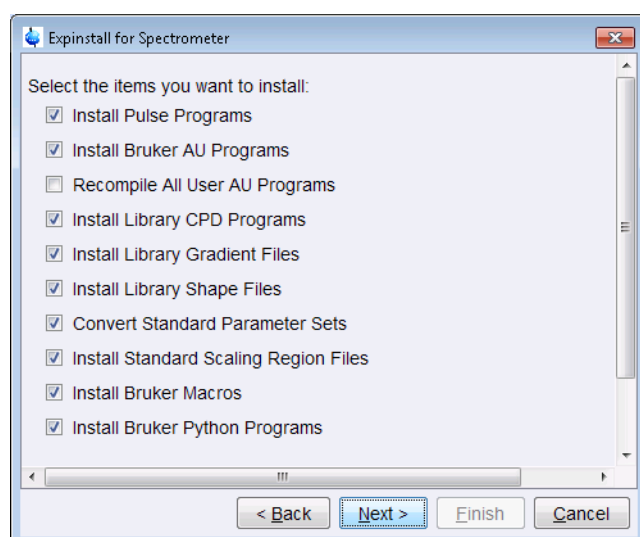
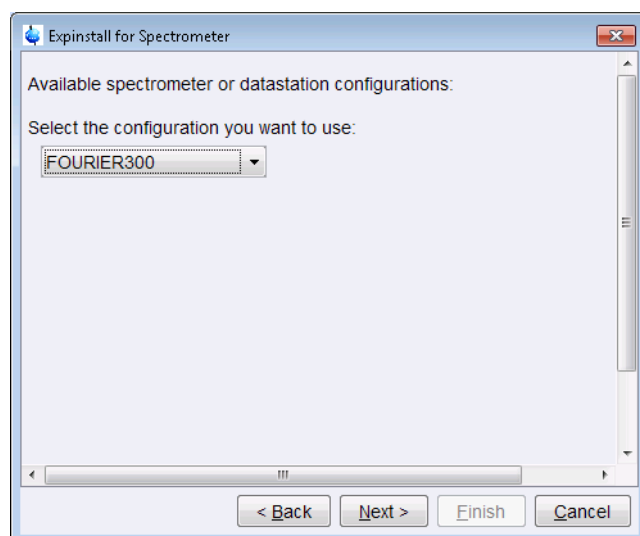

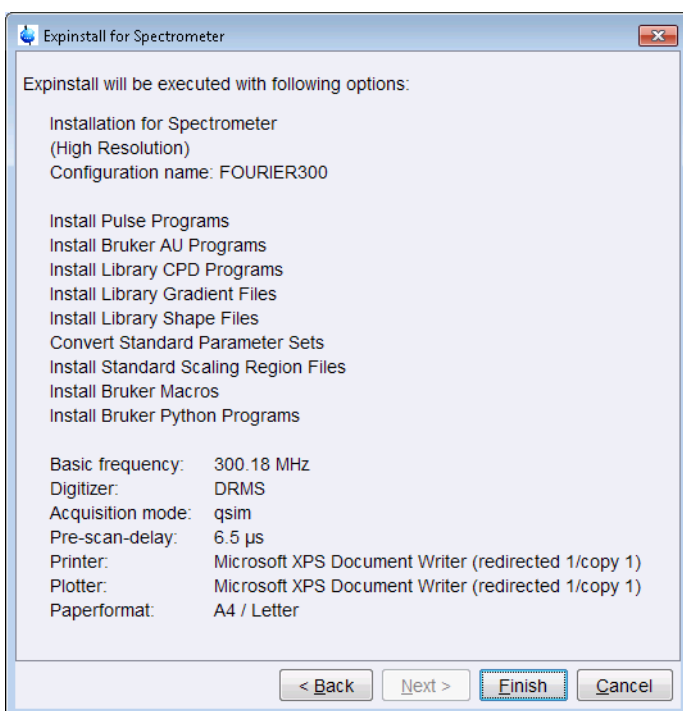
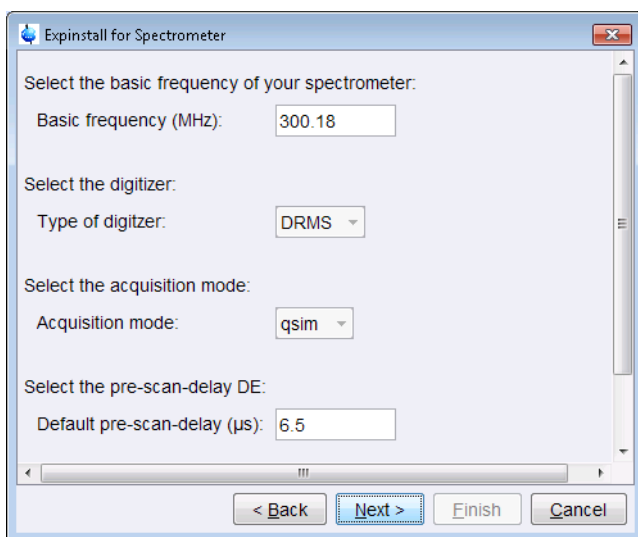

## 6.7.2 Editing Solvents

The list showing the common solvents in solution NMR is shown and can be edited in the same way as the nucleus list.

### 6.7.3 Configuring the Probe

The command **edhead** is used to make the probe specific parameters known to the spectrometer. Modern NMR probes use a special memory called PICS to store these data. This PICS memory can be read by the HPPR preamplifier system via a cable connection. This is not available on the Fourier system. Therefore, all parameters must be either be set manually (see below) or you should copy the probe.ph file, which is delivered with the probe to the directory

“conf/instr/FOURIER300”

before running EDHEAD. Then select the probe you have installed. The probe which comes with the Fourier system is a DUL 13C/2H-1H Z-Grad probe.

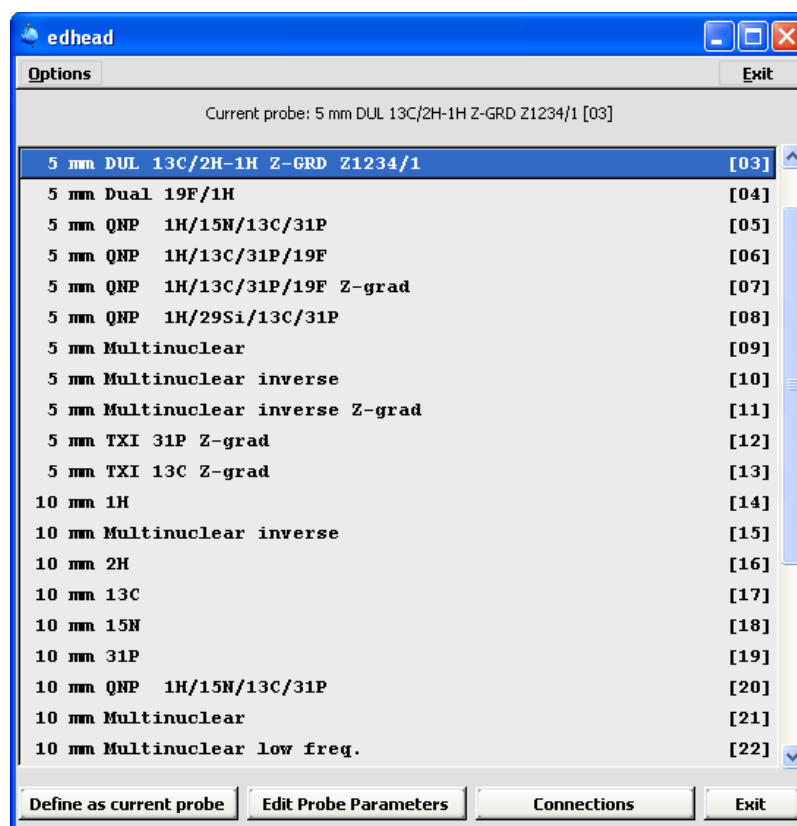

Click on **Edit Probe Parameters** to define the probe. All values necessary for that are delivered on a spec sheet which can be found in the probe case.

The most important ones are the shown here:

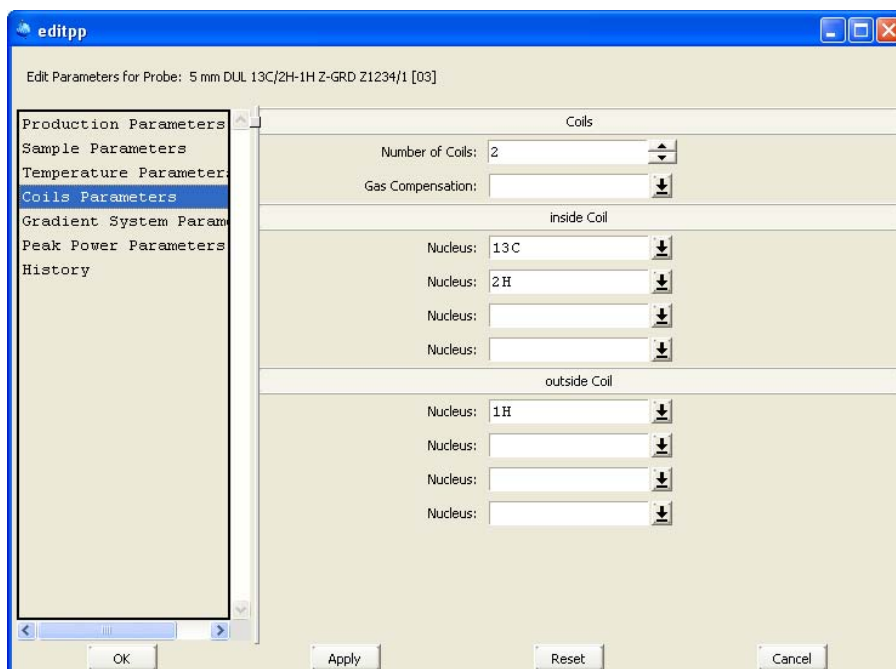
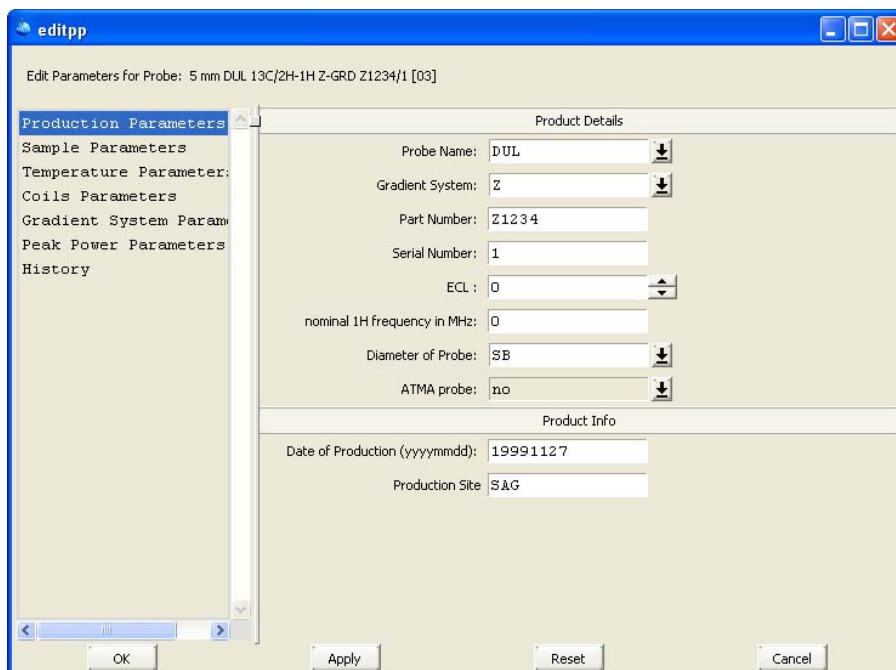

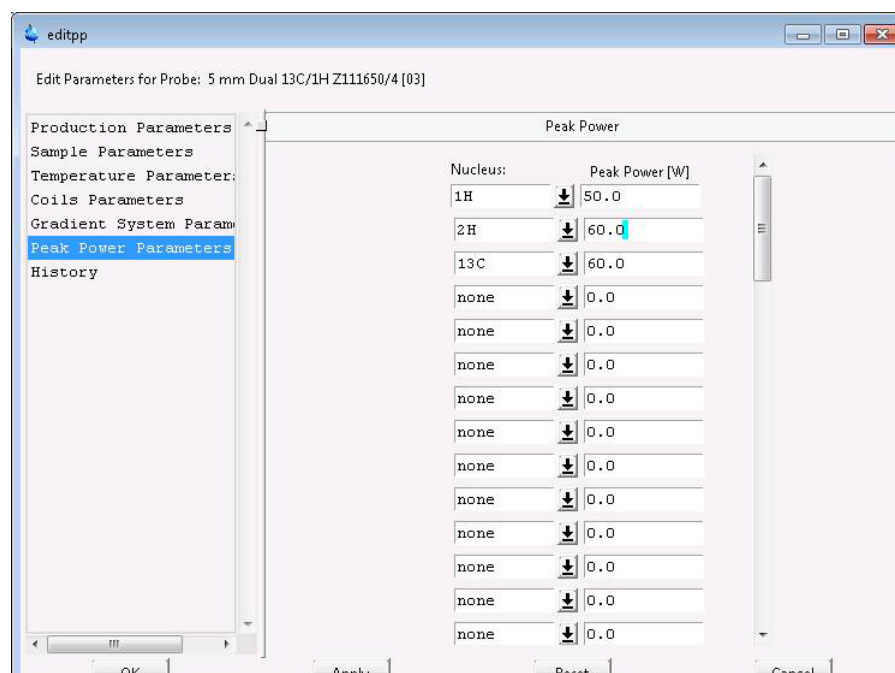

The last step of probe definition is the signal routing to the preamplifiers which looks like the figure below:

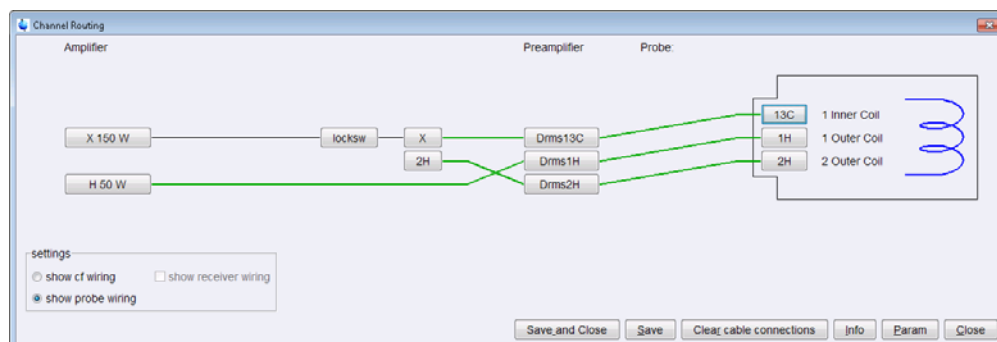

## 6.7.4 Configuring the Lock Parameters

**edlock** gives access to the lock parameters being used for different solvents. The lock parameters for the Fourier are different from those for the Avance BSMS. Whereas the solvent related parameters as “Distance” (in ppm) or “Field-Correction” (in Hz) are unchanged, the hardware related parameters as “Lock Power” and the PID values are different. The Fourier comes with its own list which is installed by **cf**.

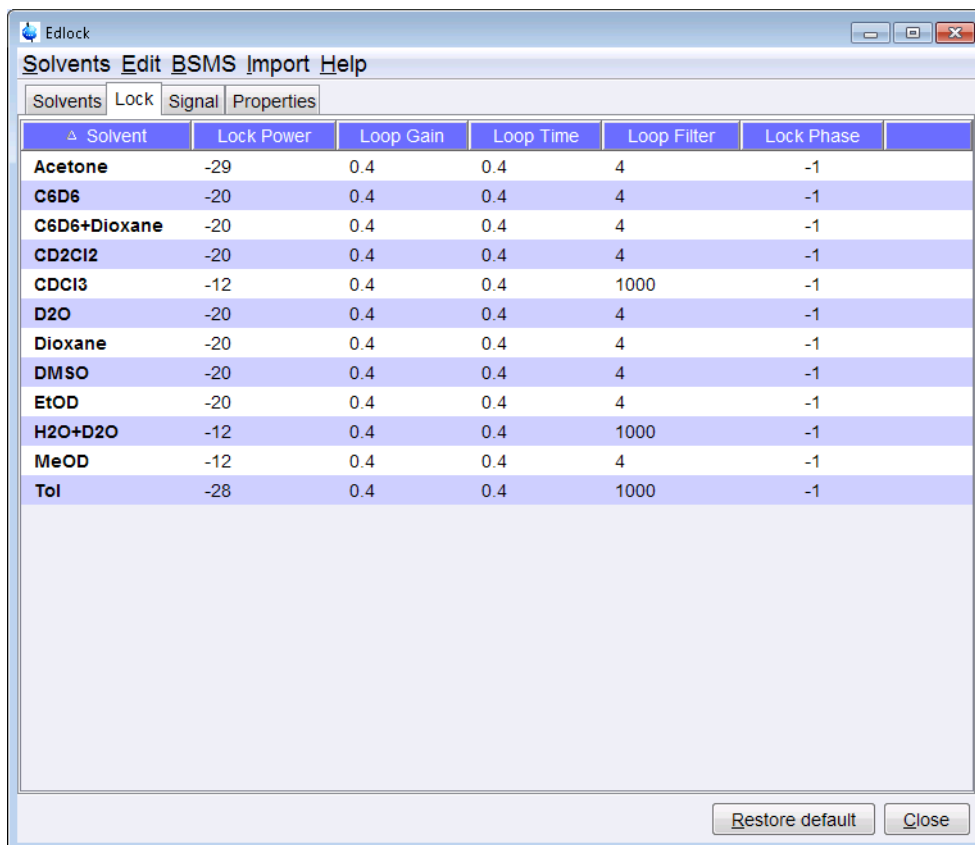

The Edlock Solvents window displays a table with the following columns: Solvent, Lock Power, Loop Gain, Loop Time, Loop Filter, and Lock Phase. The data is as follows:

Δ Solvent	Lock Power	Loop Gain	Loop Time	Loop Filter	Lock Phase
Acetone	-29	0.4	0.4	4	-1
C6D6	-20	0.4	0.4	4	-1
C6D6+Dioxane	-20	0.4	0.4	4	-1
CD2Cl2	-20	0.4	0.4	4	-1
CDCl3	-12	0.4	0.4	1000	-1
D2O	-20	0.4	0.4	4	-1
Dioxane	-20	0.4	0.4	4	-1
DMSO	-20	0.4	0.4	4	-1
EtOD	-20	0.4	0.4	4	-1
H2O+D2O	-12	0.4	0.4	1000	-1
MeOD	-12	0.4	0.4	4	-1
Tol	-28	0.4	0.4	1000	-1

Buttons at the bottom: Restore default, Close

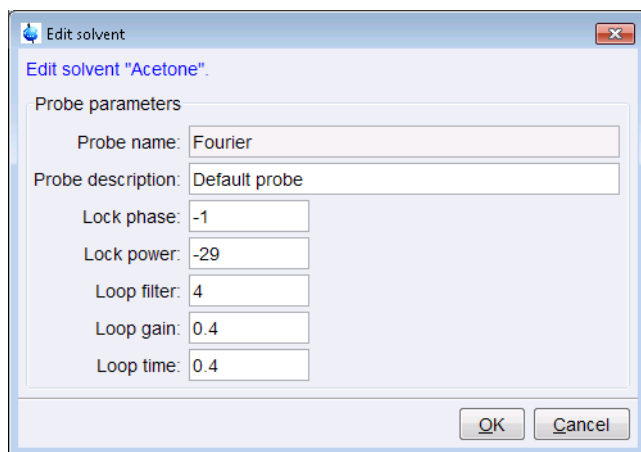

Edit solvent "Acetone".

Probe parameters

Probe name:

Probe description:

Lock phase:

Lock power:

Loop filter:

Loop gain:

Loop time:

Buttons: OK, Cancel

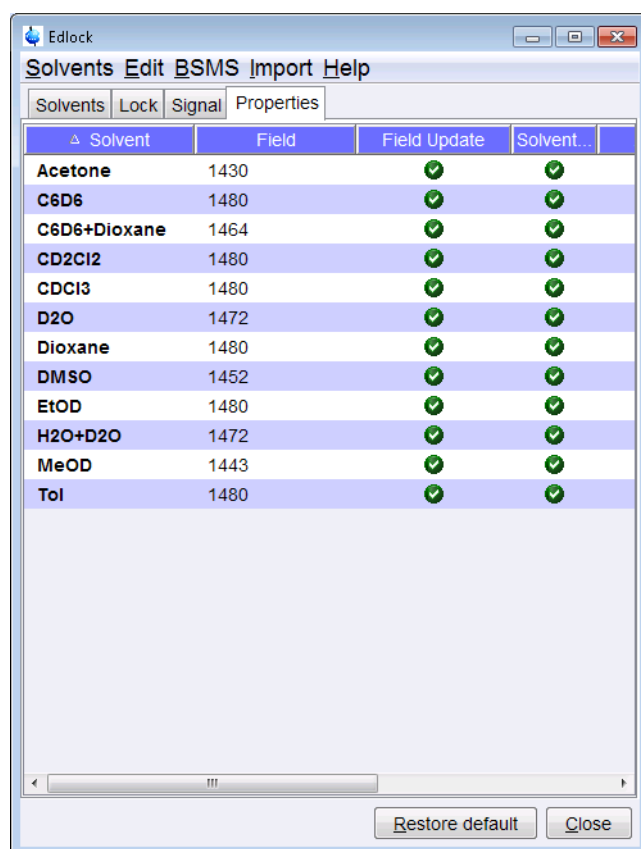

The screenshot shows the Edlock software window with a menu bar (Solvents, Edit, BSMS, Import, Help) and a toolbar (Solvents, Lock, Signal, Properties). Below the toolbar is a table with the following data:

Δ Solvent	Field	Field Update	Solvent...
Acetone	1430	✓	✓
C6D6	1480	✓	✓
C6D6+Dioxane	1464	✓	✓
CD2Cl2	1480	✓	✓
CDCl3	1480	✓	✓
D2O	1472	✓	✓
Dioxane	1480	✓	✓
DMSO	1452	✓	✓
EtOD	1480	✓	✓
H2O+D2O	1472	✓	✓
MeOD	1443	✓	✓
Tol	1480	✓	✓

At the bottom of the window, there are two buttons: "Restore default" and "Close".

### 6.7.5 Configuring the Transmitter and Preamplifier Pre-delays

The command **edscn** allows to set the pre-delays for the transmitters and preamplifiers. Currently, these are not used by the Fourier system. Instead, they are preset to reasonable values. These can be changed on the Fourier web page. This may be changed in future releases. For now, changing these values will not effect the hardware settings.

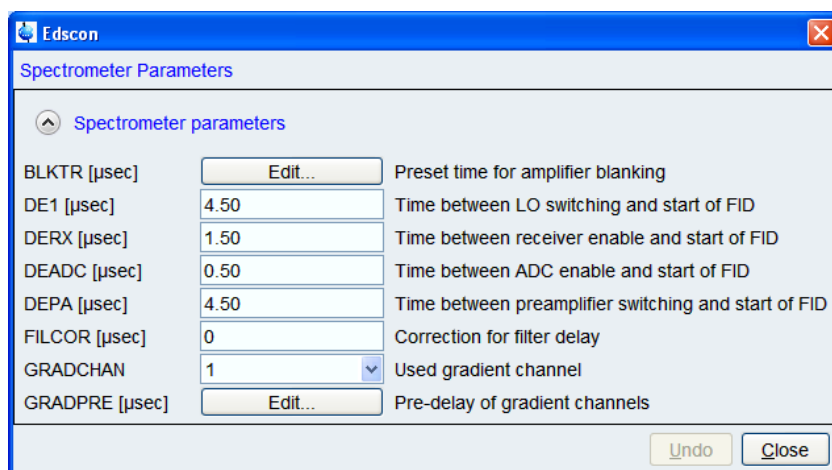

## 6.8 Setting the magnet to the right field

The magnet is designed to be operated at **300.18 MHz** with the current in the H0 Field Coil of the Shim System set to zero. At this frequency the Synthesizers are "cleanest" and least likely to create spurious problems

! When the lock is powered up from cold, the Field DAC is not automatically set. In order to make sure the current in the Field Coil is set to zero,

- Open the BSMS panel.
- Set the Field Value to 2048 and switch the lock to ON once.
- Switch it off again, while the magnet is being charged to the right field and the cryoshims are adjusted.

## 6.9 The Lock System

### 6.9.1 Working with the Lock System

The Fourier lock system is very similar to the BSMS lock. The BSMS Control Suite is fully functional and for normal operation, the differences are negligible.

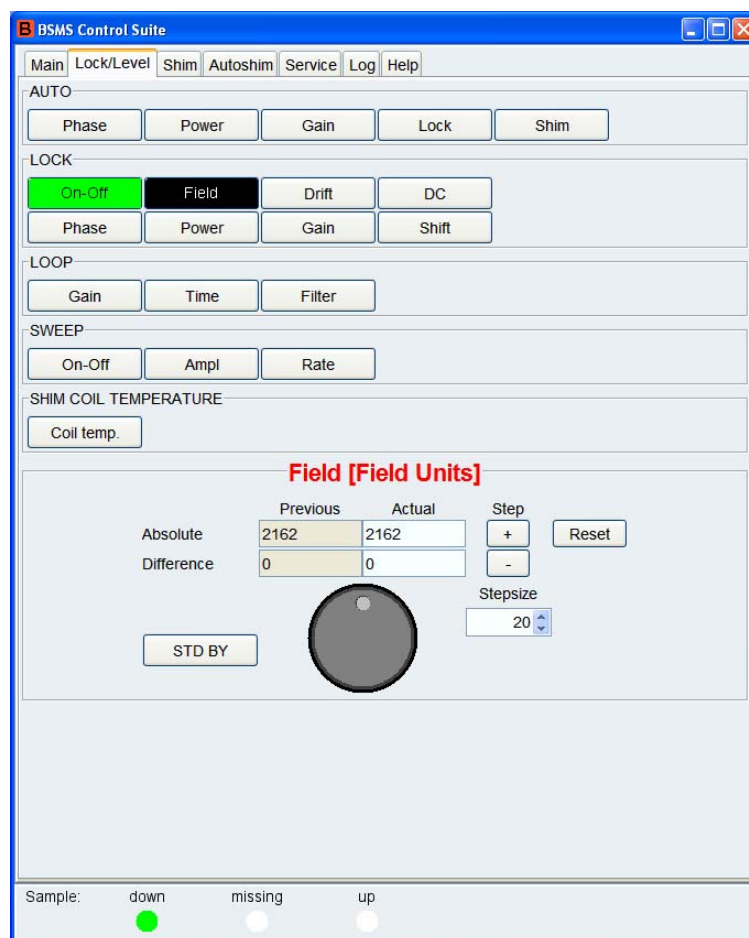

As explained in the previous chapter, some of the parameters have a different value range. This applies mainly to the PID parameters. Increasing loop gain and loop time results in a more rigid coupling to the lock signal (fast regulation with a higher risk to see lock artefacts in the baseline next to intense resonance lines). Decreasing them results in less coupling (slow regulation, not suited to fast disturbances, but less baseline artefacts).

The “loop filter” is only applied on the lock data as they are displayed on the screen. The higher the value, the more data points are averaged to reduce noise.

## 6.9.2 Finding a Lock

If the lock is set up correctly, there is no need to search for the lock manually. The **lock** command will result in the lock system to read all parameters from the edlock file and to perform an automatic search and lock procedure.

During installation or in case the magnetic field changed by a considerable amount, it is necessary to find the lock signal for at least one solvent. This way, the field value defining the  $B_0$  shim current can be set correctly.

There are two possibilities to find the lock.

## First approach: Sweeping the $B_0$ field.

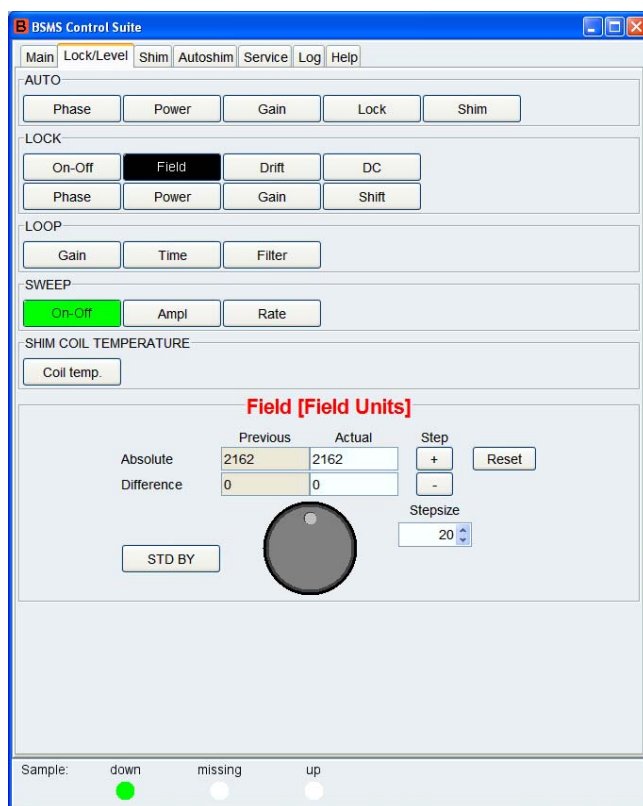

On the BSMS panel the sweep mode can be activated. The range (Ampl) and rate of the sweep can be adjusted. If there is no signal close to the current field value, the lock window only shows a noisy baseline. Use the "Field" value from the BSMS panel to search for the lock signal. Don't increase the value too fast because it is easy to miss the signal otherwise. The lock signal looks like this if the field value is correct: symmetric around the middle of the screen with both leading edges of the signal showing up. The latter must be achieved by adjusting the "Phase" of the lock.

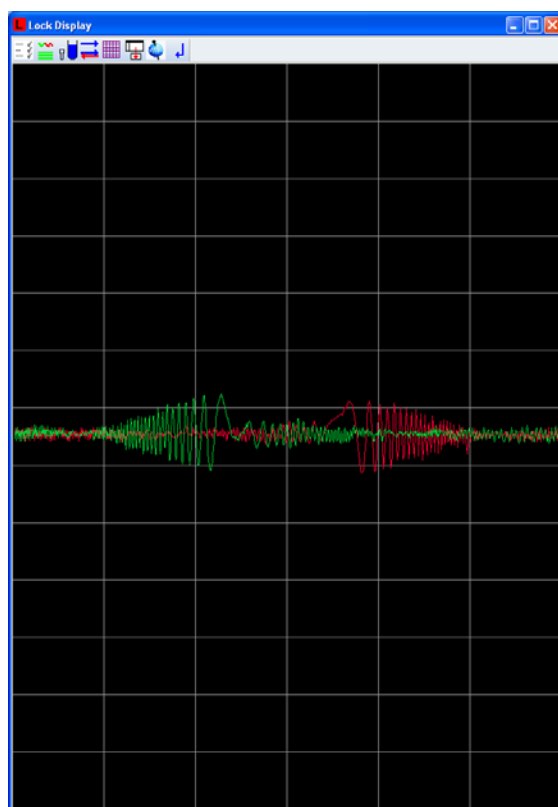

Once, these parameters are set correctly, open the **edlock** window. Select „BSMS“ in the menu and press Field Update. Leave the Phase set to -1, since this is stored by the lock control.

The screenshot shows the "Edlock" window with a menu bar (Solvents, Edit, BSMS, Import, Help) and tabs (Solvents, Lock, Signal, Properties). The "Solvents" tab is active, displaying a table with the following data:

Δ Solvent	Lock Power	Loop Gain	Loop Time	Loop Filter	Lock Phase
Acetone	-29	0.4	0.4	4	-1
C6D6	-20	0.4	0.4	4	-1
C6D6+Dioxane	-20	0.4	0.4	4	-1
CD2Cl2	-20	0.4	0.4	4	-1
CDCl3	-12	0.4	0.4	1000	-1
D2O	-20	0.4	0.4	4	-1
Dioxane	-20	0.4	0.4	4	-1
DMSO	-20	0.4	0.4	4	-1
EtOD	-20	0.4	0.4	4	-1
H2O+D2O	-12	0.4	0.4	1000	-1
MeOD	-12	0.4	0.4	4	-1
Tol	-28	0.4	0.4	1000	-1

At the bottom of the window, there are two buttons: "Restore default" and "Close".

There is a problem with this approach which also applies to the BSMS. The lock sends a series of RF pulses with a rate of 1kHz to the 2H coil. This results in an excitation profile of a central peak and a number of additional peaks on a 1kHz grid. These slowly decay in amplitude as their distance to the central peak increases.

Setting the sweep to a large amplitude clearly shows the problem.



There is more than one "resonance" due to the excitation grid and it is not obvious which one is due to the central peak.

The rate of RF pulses on the BSMS is 6.66kHz. So, the effect is less obvious and the determination of the right sweep signal is much easier.

## Second Approach: The "flock" AU Program

There is an alternate way of finding the correct lock field. Instead of using the lock instruction, it is possible to start an AU program called flock. flock asks for the lock solvent, creates a temporary 2H dataset and starts an acquisition to find the lock signal in the 2H spectrum. It compares the ppm shift of the 2H signal to the default value from the edlock table. The difference in ppm is then converted to a shift in the lock field. The new lock field is displayed in a pop-up window. Additionally, flock informs the operator how many solvent peaks have been found and if this number is in agreement with the number of resonance lines for the selected lock solvent. In case, the number of signals is different from the expected value, flock uses the peak with the highest intensity to calculate

the lock shift. The new shift value is set in the Fourier and a normal lock procedure is started.

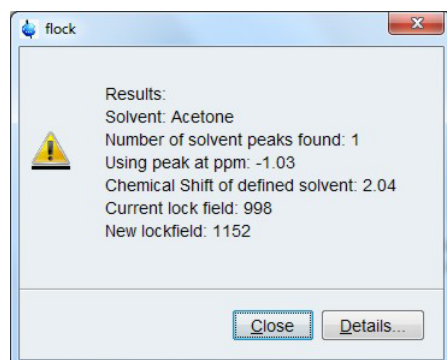
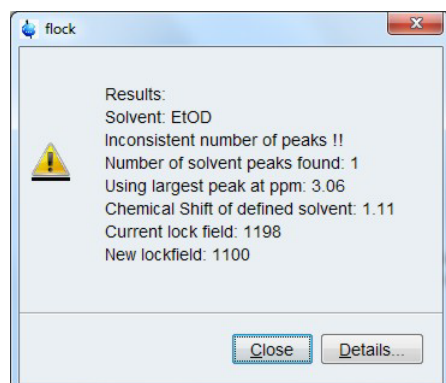
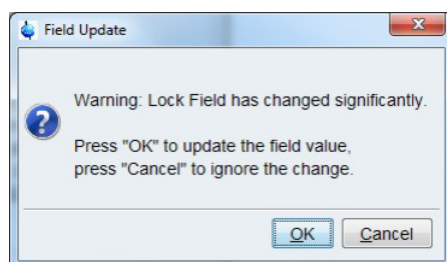

Figure 6.2 Result of Flock with one Solvent Peak



**Result of flock if number of detected peaks is not compatible with number of expected solvent peaks. This can happen if a mixture of solvents is used or if the wrong solvent has been chosen. In any case, it leads to a field lock. The ppm scale may be shifted if the wrong solvent has been chosen, though.**

Any time, the lock field has changed by a large amount, the following message is shown.



Pressing OK updates the BSMS field value in edlock table. A subsequent lock procedure should be able to find the lock signal in the usual way.

## Fine-tuning the flock AU program.

In the AU program, one can find the line:

```
static const double scale = 19.79;
```

It defines the ratio between the ppm scale and the BSMS field values. In principle, any Fourier should be close to that value. It is recommended, though, to calibrate it for any instruments as the shim current boards are not completely identical to each other.

To determine this value, one has to acquire two proton spectra. For this the Lock should be OFF. After acquisition of the first spectrum, one changes the lock field by 1000 units (+/- doesn't matter). With the new field value another spectrum is acquired. Now, determine the ppm shift of the two spectra in respect to each other, e.g. in the dual display mode. This value should be close to 20ppm. Please correct the line of the AU program shown above to reflect the accurate value (take the absolute value, no negative sign).

## Third approach: Acquisition of a proton spectrum

An easier and unambiguous approach is to acquire a proton signal using a large spectrum width SW. The easiest sample is "Doped Water" with just one large resonance line from H<sub>2</sub>O. The solvent is D<sub>2</sub>O. Therefore, the lock frequency in ppm on the 2H scale is very close to that of the proton spectrum on the 1H scale (= 4.7ppm). First try to lock on D<sub>2</sub>O in order to transfer the lock parameters for D<sub>2</sub>O to the lock system. The lock will fail because we are in a situation there the signal is outside of the lock window. Otherwise, we wouldn't need to search for the lock. With the "Sweep" set to off, change the field value such that the 1H resonance line is at 4.7ppm. This is also the right field value for the lock signal. Now, inspecting the lock window, it is possible to set the phase correctly. Save both values in the "edlock" window to finish the procedure.

The procedure is illustrated using Cyclosporine as a sample. There is always a resonance line from the protonated lock solvent because chemical exchange is easy between 1H and 2H. In cyclosporine, it is the largest signal on the left-handed side of the spectrum resulting from C<sub>6</sub>D<sub>6</sub>H.

If the field value is off, it may look like this.

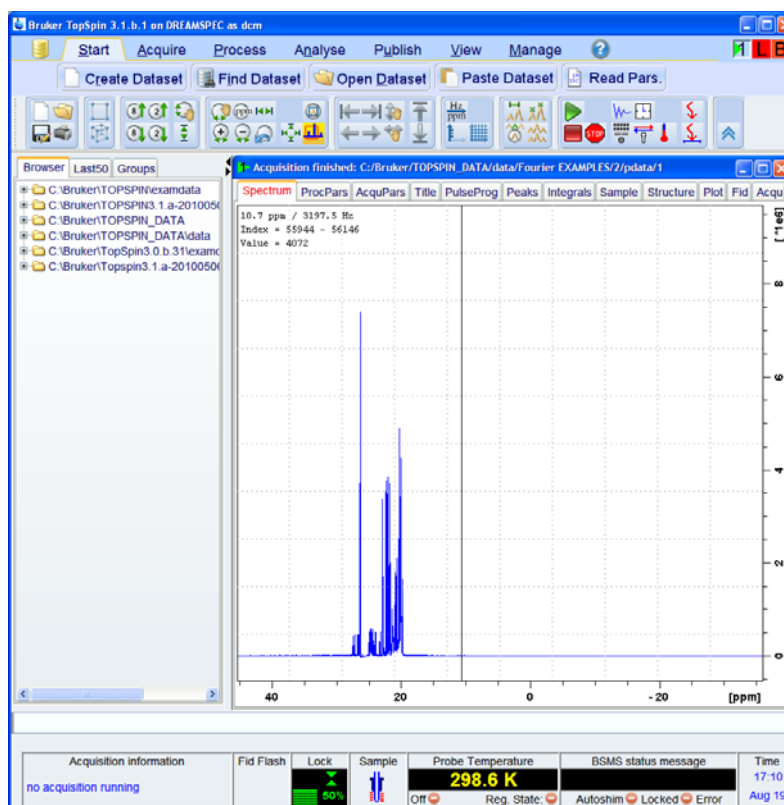

Here is a zoom to the region of interest. The resonance line is at 26.22 ppm.

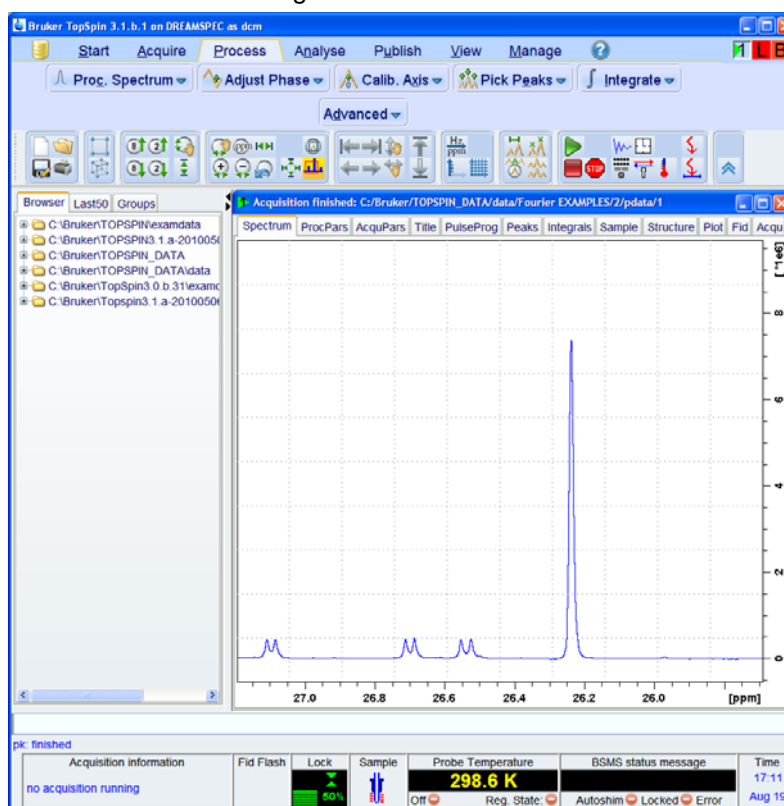

From the edlock table, one can read that the C6D6 chemical shift for 2H is 7.16ppm. So,

use the field value to shift the proton resonance line to that value on the 1H frequency scale. A rough value for the field shift is 20ppm/1000 field units. It depends a bit on the actual shim board but can be a good starting point for all Fourier systems.

There is no need to be exact at this point. A spectrum like this is close enough. Using the resulting field value, the Fourier must be able to lock the field in the automatic mode.

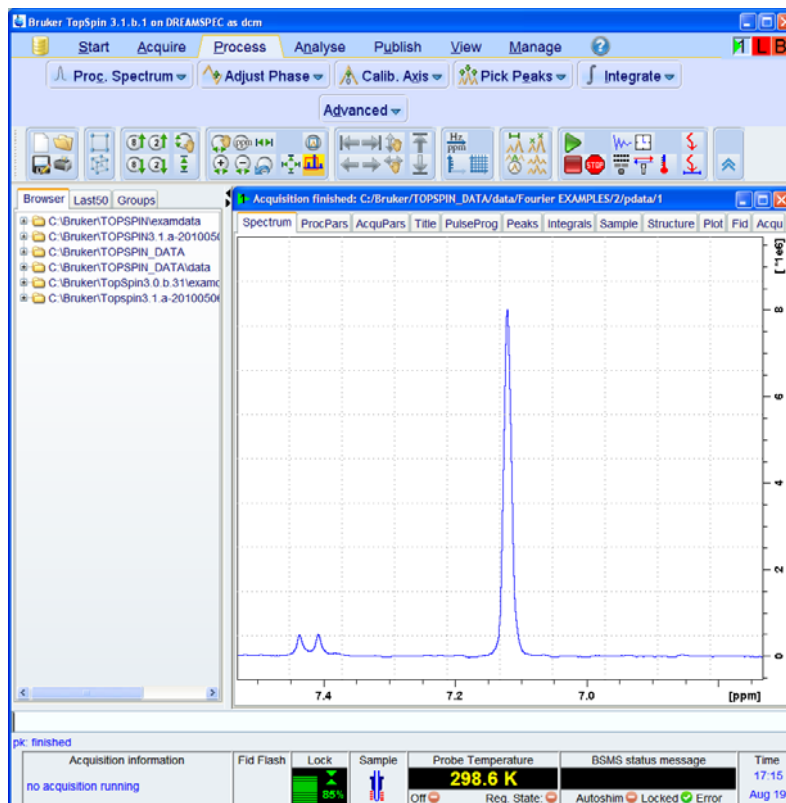

## 6.10 Converting the Parameter Set to the actual BF1

Since the shimming process may have an effect on the B<sub>0</sub> field, it may be necessary to redefine BF1 after Shimming and Lock have been optimized. The ideal BF1 is close to 300.18 when the Lock Field DAC is close to 2000 (±500).

When you are satisfied that you have a good BF1 and the LOCK DAC is near its center, repeat "CF and expinstall" with the new BF1.

## 6.11 Tuning and Matching the Probe

---

### 6.11.1 General Information about the Fourier Probe

---

The Fourier system is delivered with a special probe. It is a modified DUL probe with 13C and 2H on the inner coil and 1H on the outer coil. The special feature is a coil design which is much less susceptible to the salt content of the sample. Tuning and matching are much less influenced by a change of the sample. Therefore, the probe is tuned and matched once and this calibration is not changed on a running system. The side effect is a lower S/N ratio by about 15% compared to a normal DUL probe.

There are no tuning and matching rods on the bottom of the probe. The tunable capacitors are accessible via small holes in the upper part of the probe body. Use the screwdriver coming with the probe to tune and match the probe before installing it into the shim system.

The wobb routine of the Avance system doesn't work with the Fourier. Instead, there is a special wobb program which must be started outside of TopSpin.

See also chapter "[Additional Test Applications](#)" on page 114 for details.

## 6.12 The Gradshim Command

---

In order to enable automatic shimming, the probe is equipped with a z gradient. Unfortunately, TopShim doesn't fit to the pulse programmer structure of the Fourier system. Therefore, Gradshim is used instead.

It should be noted that only z gradients can be used for shimming. The focus is not so much on the ease of installation but more on the automatic shimming when the spectrometer is running in automation.

Gradshim works best when the shim map was made with an already well shimmed magnet. You can also use a shim map from another system to get started, since the Fourier Shim Control and BOSS 1 Shim Systems are fairly consistent.

Also important for the success of gradshim are:

- The gradient echo is nicely centered in the spectral width - check by loading and running the experiment gradshim1d2h\_f.

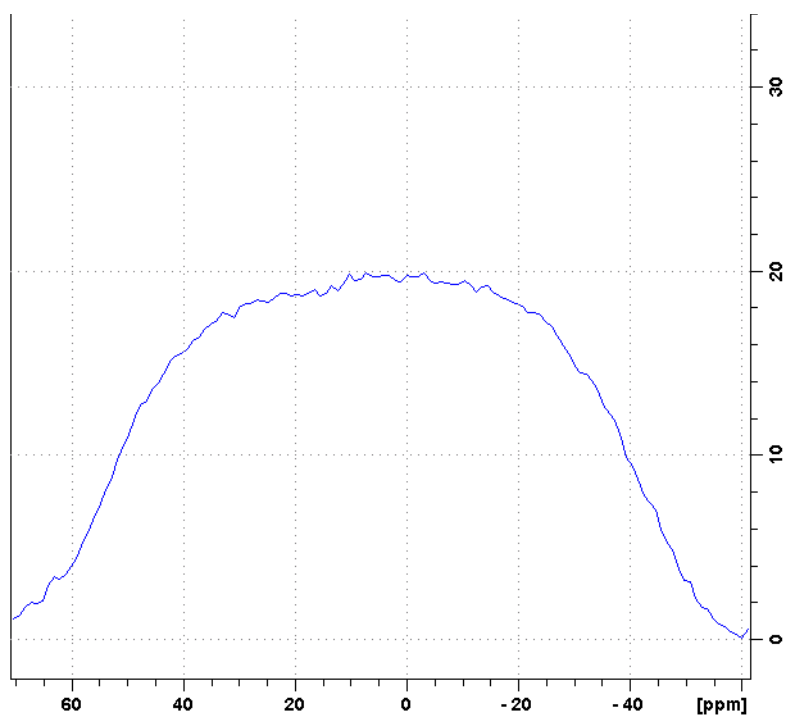
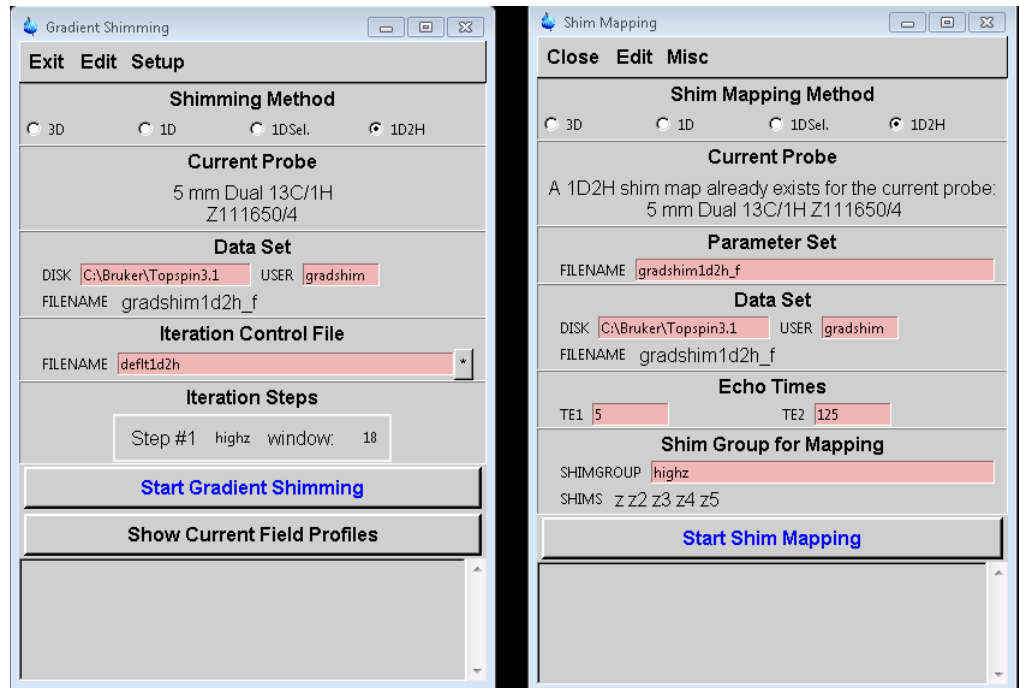

Figure 6.3 Gradient echo

- If this does not look like in the figure above, it could be, that the parameter sets have not been converted to the correct BF1.
- The correct 2H pulse length. This is normally around 50us at 40 W and can be checked by a zg experiment, where 2H is selected as the observe nucleus. If the lock is still running while you do this, there will be spikes in the 2H spectrum!

The command **gradshim** opens a new window.



If gradshim is done for the first time on a system, the profiles of the various shim gradients must be evaluated. (open Setup in the main window).

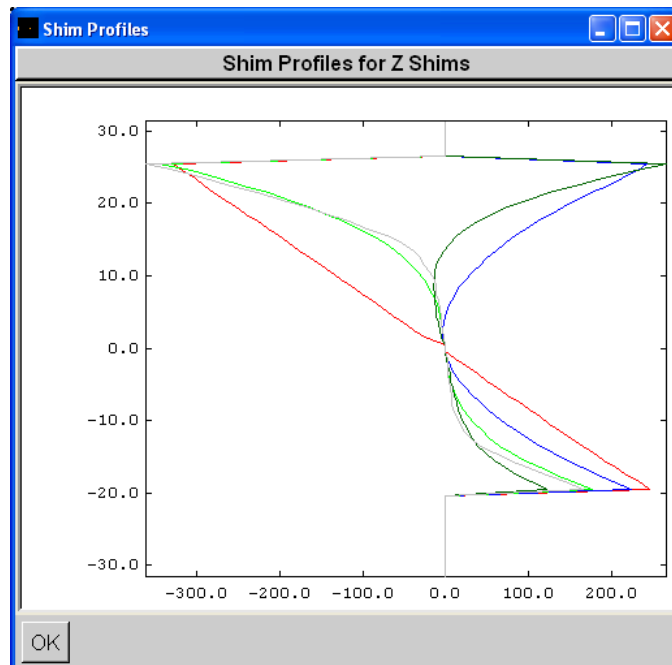

This has only to be done once. If the shim profiles are available, it is possible to “Start Gradient Shimming”.

---

**i** **IMPORTANT:** To start gradshimming using the "shim" button of the flow bar and also from IconNMR, it is necessary to store the current configuration for automation. (Setup - > store for automation). The flow bar or ICON will call either a 1H or a 2H gradshim, depending on what was selected when the setup was stored for automation.

---

For further information on gradshim please check the respective manual.

---

**i** Note: Gradshim uses different parameters on a Fourier. Be sure to define the parameter sets gradshim1d1h\_f or gradshim1d2h\_f when creating a shim map.

---

## 6.13 Installation Acceptance

---

**i** Note: All the for the Fourier 300 necessary Hardware Tests (HWT) were carried out during console end testing and are not intended to be repeated at the customer site.

---

The following ATP tests are carried out on the FOURIER during customer acceptance

- Determination 90 degree 2H observe pulse
- Determination 90 degree 1H observe pulse
- Determination 90 degree 13C observe pulse
- Determination 90 degree 1H decoupling (CPD) pulse
- Determination 90 degree 1H high power decoupling pulse
- Determination 90 degree 13C low power decoupling pulse
- Lineshape test for 1H with rotation
- Resolution test for 1H
- Sensitivity test for 1H
- Lineshape Test for 13C with rotation
- Resolution test for 13C
- Sensitivity test for 13C (ASTM)
- Sensitivity test for 13C (EB)
- HSQC experiment with Z-gradient (console test)
- COSY experiment with Z-gradient (console test)
- DEPT-90 experiment
- DEPT-135 experiment

## For the ATP Tests you will need the following samples

The three Test Samples which were shipped with the system.

- 3% CDCl<sub>3</sub> in Chloroform (lineshape)
- 0.1% EB in CDCl<sub>3</sub> (1H SINO)
- ASTM (C13 SINO)

To shim the magnet and perform the ATPs test you will require to bring some additional samples:

- Urea in DMSO (Pulse Length adjustment)
- 100mg or 1g Cholac in CDCl<sub>3</sub> (DEPT)
- Cyclosporine in C<sub>6</sub>D<sub>6</sub> (2D Examples)

There are only three hard specs for the Fourier required for a customer sign off:

Lineshape using 3% CDCl <sub>3</sub> in Acetone	0.5/8/16 Hz (non-spinning)
1H Sensitivity (0.1% EB in CDCL <sub>3</sub> )	125:1 (after gradshim)
C13 Sensitivity (ASTM)	90:1 (after gradshim)

Table 6.1 Hard specs for the Fourier

The remaining ATP Tests will implicitly demonstrate the system remaining functions:

- Water Supression
- Sample Spin & Lift
- Auto-Locking on various solvents
- Gradient Functionality (2Ds & Gradshim)
- Gradshim reproducibility
- Lock and Temperature Stability (COSY & HSCQ)
- \* Baseline & Spectral Purity (DEPT)

### \* Certain Artefacts are normal and have been considered acceptable for the intended use of the Fourier:

- A moderate amount of T1 noise in 2D experiments
- Some "digital noise" on strong signals that require RG < 10. Use zg30 instead zg of if that happens, in order to be able to increase RG
- Some vibration noise close to the feet of very narrow lines (e.g. lineshape samples). This can be improved with vibration damping if required.
- \* Some very small spurious spikes in the first few scans of C13 spectra. These should average out after NS > 64

- "Asymmetric smileys" in some 1D spectra with high intensity. This can also be seen as reduction in the level of noise about 200 Hz from the right edge of some 1D and 2D spectra. If this part contains spectral information, simply increase the spectral width.

\* If you obtain reproducible "spurious spikes" in 1H spectra it may be due to an unfavourable BF1 frequency. The Fourier DDS are "clean" for at least 200ppm round 300.18 MHz

## 6.14 Main Differences between Fourier & Avance Systems

---

- The Lock works at 1 kHz instead of 6 kHz. That means that sidebands are closer together. Also the lock parameters have different units to BSMS Values.

Typical Values for the Fourier are:

P: 0.1 to 0.8 depending on solvent.

Higher values mean more proportional gain.

I: 0.1 to 0.8 depending on solvent.

Higher values mean more integral gain.

Power: -12 to -28 dBm depending on solvent.

**Note:** The values shown in the BSMS Panel are attenuations from 0dBm.

Filter: 4 for strong solvents, 1000 for weak solvents. The numbers are not the Bandwidth in Hz but the number of averages per second. 1000 is equivalent to 1 Hz, 4 is equivalent to 250 Hz.

Field: 0 to 4095. 2048 means no current flowing in H0 Coil.

Ideal value is between 1500 and 2500, to allow for magnet drift. The BSMS field has the opposite polarity, i.e increasing the value of the field DAC by 1000 steps will cause a shift left (i.e increase the frequency) by 20 ppm.

- Shim Values go from -32768 to 32768. If converting from a AVANCE shim file, you will need to halve the values to get a good starting point.
- No PID Self Tune for Lock, VTU and Spin Parameters. Since the Fourier is only sold with one probe, the defaults if operated at 4 bar are usually good enough for all experiments.
- Different Pulse Programmer Language
- Digitizer Type must be set to "DRMS"
- Aq.mod must be set to qsim
- Fn\_Mod must be set to TPPI or QF
- BC-Mod must always be set to OFF
- GPNAM must always be RECT.1

# 7 Configuration

Each of the three Ethernet Devices has an ARM CPU with a web server for service, BIS setup and diagnostic functions.

In order to prevent accidental damage, the web server access is password protected:

User: **root**

Password: **BRUKER (in capitals !!)**

You can connect to the web server using any browser, but Firefox is recommended in case you want to save to password.

## 7.1 Network Settings

The arm CPU receives its IP address by different methods, selected by jumpers on the dip switch shown below. The default for use with TopSpin is DHCP, i.e. (X, ON, OFF, OFF (X = don't care)

If for any reason you cannot connect to a device, it may be necessary to set the jumpers to a default address (e.g. X,OFF,OFF,ON for 192.168.1.1)

**i** Notice: Both the lock board and the main board are based on the minispec architecture, so if they are set to X,OFF,OFF,OFF will both default to 192.168.1.200. The VTUs default is 192.168.1.109.

It is also possible to assign a fixed user specific IP address.

### Main -> support -> network configuration

Parameter	Software	EEPROM	Modify EEPROM
IP address:	192.168.1.1	149.236.42.97	<input type="text" value="149.236.42.97"/>
Subnet Mask:	255.255.255.0	255.255.255.0	<input type="text" value="255.255.255.0"/>
Standard Gateway:	0.0.0.0	0.0.0.0	<input type="text" value="0.0.0.0"/>
MAC Address:	0000AD0BFF12	0000AD119C12	---
SW2 jumper settings:	OFF, OFF, ON	ON, ON, ON	---

This address will be used if the jumpers are set to X,ON, ON, ON.

Figure 7.1 Fixed User Specific IP Address

# Configuration

The jumper settings are described on each web server under

Main -> help-> power up jumper

## Fourier Power up jumper

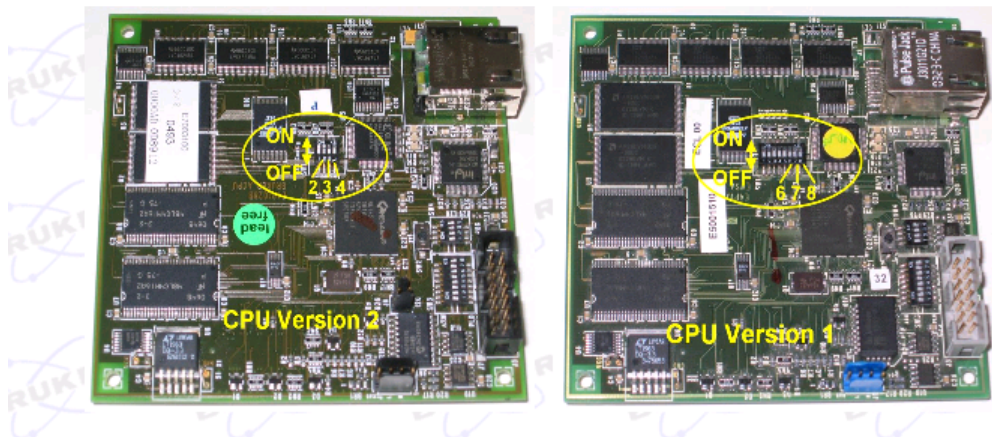

2 / 6	3 / 7	4 / 8	DHCP	BOOTP	MAC address	IP address
						no hardware found
						Hall
						Signal Channel
						Bridge
						ENDOR
OFF	OFF	OFF	no	no	defined by serial number	VTU
						Teslameter
						Signal Channel 2
						Gradient Unit BMC20
						SPU
						Cryo Power Supply
						MiniSpec
OFF	OFF	ON	no	no	0x0000AD0BFF12	192.168.1.1
ON	ON	OFF	yes	yes	defined by serial number	from DHCP/BOOTP server
OFF	ON	OFF	no	yes	defined by serial number	BOOTP server
ON	OFF	OFF	yes	no	defined by serial number	DHCP server
ON	ON	ON	no	no	defined by serial number	user defined

Figure 7.2 Power Up Jumper

## 7.1.1 Resetting the CPU

Any change in network configuration, firmware or FPA content are only valid after rebooting the CPU. There are three ways to reset the CPU:

- Power up
- Pressing the reset button on the CPU
- Pressing “Hardware reset” button in the web server under

### Main -> support -> network configuration

This button also appears after a successful firmware update.

## 7.2 Firmware Update

The firmware of all the intelligent devices can be upgraded during run-time via the web-browser. The mechanism for the Ethernet Devices differs to that of the CAN-Bus Devices.

### 7.2.1 Ethernet Devices (Main Board, Lock Board, VTU)

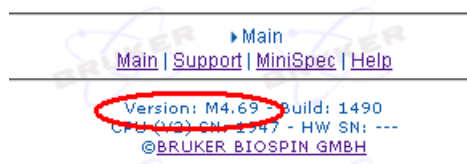

Before changing Firmware the current firmware version must be identified. In Ethernet Devices this is always shown at the bottom of each web server page.

Downloading a new firmware is initiated by:

### Main -> support -> CPU software update



1. Select the firmware to be uploaded using the “browse” button (in some versions called “Durchsuchen”).
2. Press **Upload** to upload firmware to CPU.

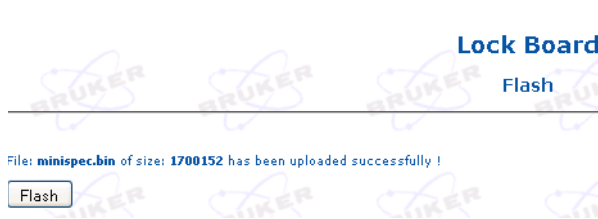

This takes a few seconds and is finished when the message appears: **File ... uploaded successfully!**

3. Press "**Flash**" to write the uploaded file into the Flash memory of the CPU.



This takes about a minute and is finished when the message appears: **Successfully Programmed Flash.**

4. Reset the CPU by pressing the **Hardware Reset** button.

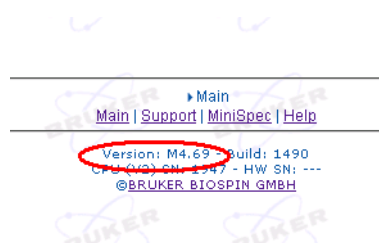

5. **Confirm the new version after the CPU has been reset.**

## 7.2.2 4.3.2 CAN-Bus Devices

**i** Notice: The procedure is the same for all devices.

The procedure is the same for all devices, however

- since the **shim control** board and the **GAB/2** Board are slaves of the fourier main board, the firmware update of these devices is initiated form the **main board** web server.
- since the **peripheral control** board is a slave of the VTU, the firmware update of this devices is initiated form the **VTU** web server.

The procedure is started using

## Main -> support -> AVR Controller software update

1. **Select Device** and Board Number and press **SET**.



Notice: GAB/2 Backplane and Peripheral Control the Board Number is always “Board 1” Since the shim control comprises two boards, this procedure has to be carried out twice. Once for Board1 and once for Board2.

2. Select the EEPROM file (file ending \*.eep) to be uploaded by clicking on **Upload EEPROM Data**.

This procedure takes less than a second and is finished when the message appears: **Flash EEP File**.

3. Press **Flash Eep-File** to write the file to the EEPROM.

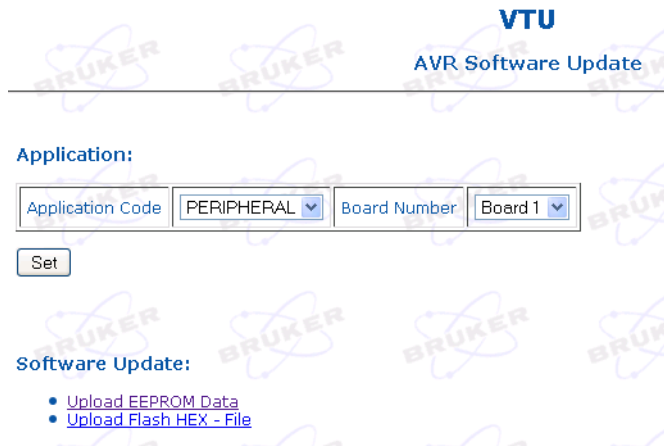

This procedure takes about 30 seconds and is finished when the programming menu reappears.

## Hex File

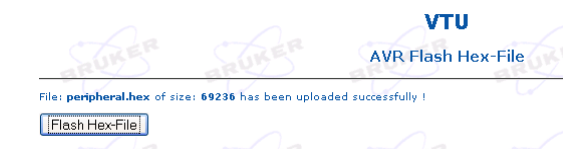

4. Repeat this procedure (Upload & then flash) for the Hex file.



This procedure takes a few minutes and is finished when the following message appears:

5. **Reset** the Master CPU (in this example the VTU) by pressing the “Hardware Reset” Button.

## Shim Control: Main Board: *main* -> *shim* -> *base function*



6. **Check** that the correct version has been successfully updated.

**GAB/ 2: Main Board: main -> fourier --> GAB/2 System -> GAB/2 Menu -> GAB/2 Control**

GAB/2 Status		
Relay Mode		on
Analog Path		on
GCON Parity Check		inactive
GAB/2 Backplane Firmware Version		V00.04
GAB/2 Backplane FPGA Version		V0.01

[Main](#) | [MiniSpec](#) | [GAB/2 System](#) | [GAB/2 Menu](#) | [GAB/2 Control](#)  
[Main](#) | [Support](#) | [MiniSpec](#) | [Shim](#) | [Help](#)

**Peripheral Control: VTU: main -> VTU -> peripheral control -> base functions**

Messages:

Function	Parameter	Method
BeAlive	<input type="text" value="Be alive"/>	<input type="button" value="Get"/>
Version	<input type="text" value="0.016"/>	<input type="button" value="Get"/>
LED	<input type="text" value="0.00"/>	<input type="button" value="Get"/>

## 7.3 FPGA Update

The FPGA Content of the Ethernet devices can be upgraded during run-time via the web-browser. The main board requires an external tool to stream the FPGA content, since the memory of the embedded web server CPU is not large enough to hold an entire FPGA image.

### 7.3.1 Lock Control and VTU

With these two devices, the FPGA is updated using the web server.

**i** Notice: Before a start the current FPGA version must be correctly **identified**.

#### Lock Board

MiniSpec Base Functions

---

**Write Command:**

Register	Value
<input type="text" value="0x00"/>	<input type="text" value="0x00"/>

**Read Command:**

Register	Value
<input type="text" value="0x04"/>	<input type="text" value="88 = 0x00000058"/>

1. Open **main->device->base functions** and read out the address of register 0x04.



2. Begin the update procedure using **main -> support -> XILINX CPLD/ FPGA Update**.
3. Select the corresponding FPGA image (file ending \*.xsvf) and press **Upload Xilinx XSVF-File**.



This takes a few seconds and is finished when the **Start** window appears.

4. Press **Start**. This procedure takes about **25 minutes !!!**

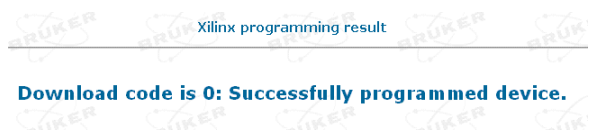

It is finished when this message appears.

5. **Reset** the CPU by pressing the **Hardware Reset** button in the menu

6. **Verify** that the new version has been correctly loaded by reading register 0x04 (see above).

## 7.3.2 Main Board

The main board requires an external tool to stream the FPGA content, since the memory of the embedded web server CPU is not large enough to hold an entire FPGA image. The procedure is therefore different (and simpler) but does need a special software tool called **Allegro Flash Tool (Flash.exe)**.

**i** Notice: Before a start the current FPGA version must be correctly **identified**. In the case of the main board this is seen at the bottom of the main web server page.

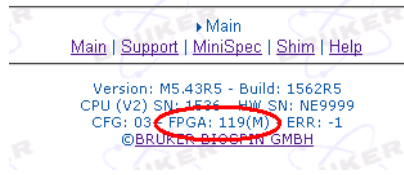

1. Identify the current FPGA version.

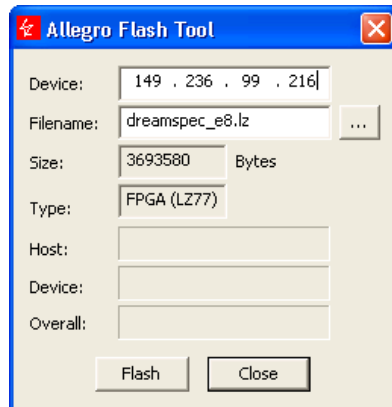

2. Start Allegro **Flash Tool** (Flash.exe), enter the IP address of the main board, and select the FPGA image (file ending \*.lz)
3. Press **Flash** to start the procedure.

This procedure takes about **35 minutes !!!**

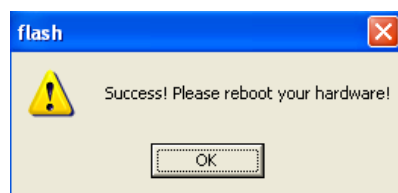

It is finished when the following message appears:

4. **Reset** the CPU by pressing the “Hardware Reset” Button in the menu **Main -> support -> network configuration**.
5. **Verify** that the new version has been correctly (bottom of main web page).

## 7.4 Device Specific Settings & Tools

Apart for the generic functions for network configuration, Firmware & FPGA Update each web server has some individual device specific functions such as:

- BIS EEPROM
- Device Identification
- Device Setup Parameters
- Diagnostic Functions

## 7.4.1 Main Board

---

### 7.4.1.1 BIS EEPROM Settings

---

In order for the main board to be recognized as a Fourier component, the following entries need to be made in NAME group part of the BIS EEPROM. This is accessed via:

Main -> minispec -> BIS information

**PRODUCTION group:**

Product ID:	E1451110
Serial number:	NE9999
ECL:	0.0
Variant:	
Location:	
Date:	14/04/2010

Apply

**NAME group:**  
Enter device identifier ("MQD"; DreamSpec).

Unit:	MQD
-------	-----

Apply

**INITIALIZATION group:**

Mode (MINISPEC or IMAGING):	MINISPEC
Internal use 1:	
Internal use 2:	
Internal use 3:	
Internal use 4:	

Apply

---

**i** Notice: The names "minispec" and "dreamspec" are historical and are used internally only.

---

Apply

**DreamSpec settings:**

Operating Frequency Min:	295
Operating Frequency Max:	305
NMR Separation Frequency:	35
DDS Sync Delay Mod1:	0x28000050
DDS Sync Delay Mod2:	0x28000048
DDS Sync Delay LO:	0x28000050

Apply

Next, further down on the same page, the **frequency range** has to be defined. For 300 MHz this is:

---

**i** Note: The three **DDS Sync Delay** parameters are board specific delay line values that are determined to make sure that all three DDSs are synchronized and should not be changed!

---

Next the dependencies and Polarities of the **service pulses** has to be defined. There are four programmable service pulses, and they are used to gate transmitters and pre-amplifiers. For each pulse the HF pulse that it should be connected to, the polarity and a pre- and/or post-delay (in multiples of 40 ns) can be defined. The default settings are:

## DreamSpec transmitter pulse (service pulse 0):

Transmitter Master (MOD1 or MOD2):	MOD2
Transmitter Blank Polarity, ST2 (0 = active high, 1 = active low):	0
Transmitter Blank Predelay / 40ns:	25
Transmitter Blank Postdelay / 40ns:	0

1H Transmitter gate  
(with 1 us predelay)

Apply

## DreamSpec preamp pulse (service pulse 1):

Preamp Master (MOD1 or MOD2):	MOD2
Preamp Protection Polarity, ST8 (0 = active high, 1 = active low):	1
Preamp Protection Predelay / 40ns:	0
Preamp Protection Postdelay / 40ns:	0

1H Preamp Gate  
(inverted)

Apply

## DreamSpec Mod2 pulse (service pulse 2):

Mod2 Master (MOD1 or MOD2):	MOD1
Mod2 Gate Polarity, ST4 (0 = active high, 1 = active low):	0
Mod2 Gate Predelay / 40ns:	25
Mod2 Gate Postdelay / 40ns:	0

C13 Transmitter gate  
(with 1 us predelay)

Apply

## DreamSpec SP3 pulse (service pulse 3):

SP3 Master (MOD1 or MOD2):	MOD1
SP3 Gate Polarity, ST9 (0 = active high, 1 = active low):	0
SP3 Gate Predelay / 40ns:	0
SP3 Gate Postdelay / 40ns:	0

C13 Preamp Gate

Apply

**i** Note: The preamp gates are not protection pulses. The preamps are self protecting using diodes, and the gate is required in order to ensure that low power pulses can pass the protection diodes.

### 7.4.1.2 Board Temperature Control

The temperature sensitive parts (Master Oscillator, Receiver Gain Stages, Filters, etc) are all within a temperature controlled zone on the main board, which is thermally isolated with a blue foam cover.

The temperature is controlled by a digital PID algorithm which runs in the background on

the embedded CPU. The PID settings can be adjusted using:

Main-> minispec-> electronics temperature control

## Fourier

### Electronics temperature control

---

**ID controller 2 (NTC):**

Chn 1	Chn 2	Chn 1 / Chn 2
6881640	6879890	1.0003

actual temperature

**heater parameter:**

Heater PID	Set value	Parameter
Proportional band	3	10000
Integral time	1483	20
Derivative time	0	0

   temperature setpoint    heater power

Temperature setpoint	Heater register	Heater power [%]	LED (counter)
1.0000	1485	36.3	TBD

A temperature setpoint of 1.0 is equivalent to about 40°C. It should be adjusted so that the heater power is between 30 and 50 % when stable conditions are reached. Adjust the setpoint if necessary (lower value -> higher temperature. The setpoint is raised by 1°C when the setpoint value is lowered by 0.05, and vice versa ).

PID Values should not need to be changed. The values are stored in the EEPROM and are valid after power up.

## 7.4.1.3 On-Board Voltages

The main board receives only 28Vdc from the central 28V PSU and generates all the other voltages it requires on board. You can test if all the voltages are correct under:

**Main-> minispec-> AD Controller**

20	[1BU]	37.255	[1BU]	[1BU]
21	28V_PA2	26.754	28	V
22	28V_PA1	22.751	28	V
23	4V	4.017	4	V
24	2V5_FPGA	2.417	2.5	V
25	3V3_FPGA	3.413	3.3	V
26	3V3_DDS	3.383	3.3	V
27	3V3_ADC	3.294	3.3	V
28	5V_DIGITAL	5.177	5.2	V
29	5V_ANALOG	5.141	5.2	V
30	28V_EXTERN	27.610	28	V

## 7.4.1.4 4.5.1.5 Pulse programmer memory

Unlike the IPSO, the Fourier keeps its entire Pulse Program (incl. decoupling sequences, loops, 2D evolutions) in memory at once. Since the memory is limited, some pulse programs may exceed the memory capacity. In order to check if this is the case, you can check the memory usage using:

**Main-> minispec-> memory**

Pulse Programmer	Command	Table
Modulator 1	10.64 %	3.22 %
Modulator 2	1.56 %	3.22 %
Receiver	1.56 %	3.17 %
Gradients	0.00 %	0.00 %
Service channel 1	1.56 %	3.13 %
Service channel 2	1.56 %	3.13 %
Service channel 3	10.64 %	3.13 %
Service channel 4	10.64 %	3.13 %

Read

## 7.4.2 Shim Control

Since shim control is a slave of the main board, the shim specific web server functions are found on the main board web server under:

Main-> shim

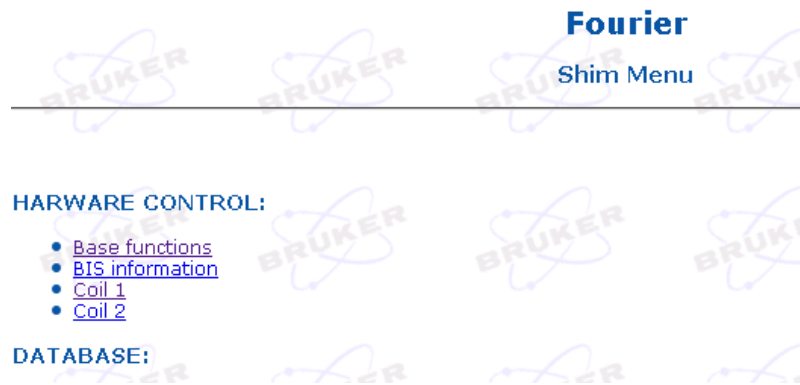

The Fourier has 20 coils for shimming. One Shim Control Board can handle 12 coils. Therefore we need two Shim Control Boards. The first Board is represented by the Menu item "Coil 1", the second Shim Control Board is represented by the Menu item "Coil 2".

### Base Functions

Here you can see the Firmware version of the two boards. If you want to test the Can-Bus communication you can toggle the 4 LED on board. If you mark the checkbox you can activate the LED. Under the item Temperature you can see the temperature of the two boards.

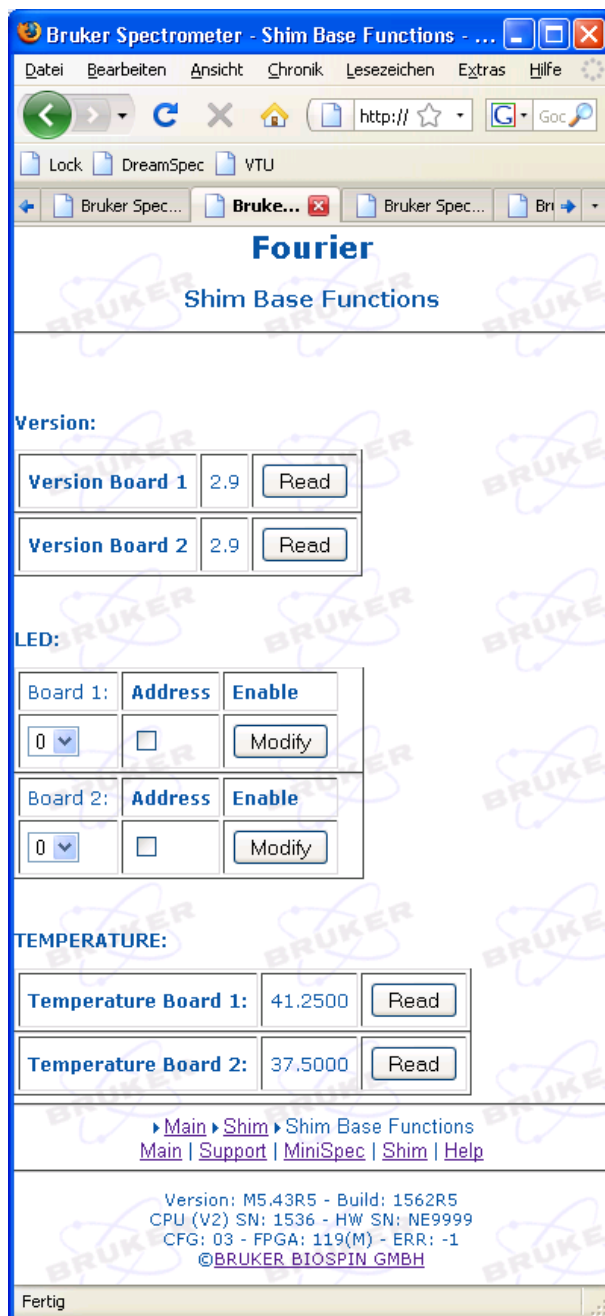

## Coil 1

On this page you can see the 12 coils which are controlled by the first Shim Control Board. The resolution of the DAC which set the current to the coils is 16 bits. 0x0000 is the maximal negative current and 0xFFFF is the maximal positive current. This means the half 0x8000 is zero current. In the column "current" you can read the current through the coil. The next column ratio shows you the ratio of the current which flows the coils and the current which should flow. This ratio should be near 1.

**i** Note:if the current is close to zero, sometimes an error "insufficient current" is shown. If you are not sure if a shim is responding, set a larger current (> 100mA) temporarily and check that the error goes away.

Coil:	name	DAC		Current [mA]	Ratio
	X	<input type="text" value="0x8000"/>	<input type="button" value="Set"/>	-0.39	1.00
	Y	<input type="text" value="0x8000"/>	<input type="button" value="Set"/>	-0.42	1.00
	Z	<input type="text" value="0x8000"/>	<input type="button" value="Set"/>	-0.16	1.00
	XY	<input type="text" value="0x8000"/>	<input type="button" value="Set"/>	-0.52	1.00
	XZ	<input type="text" value="0x8000"/>	<input type="button" value="Set"/>	-0.42	1.00
	YZ	<input type="text" value="0x8000"/>	<input type="button" value="Set"/>	0.00	1.00
	R <sup>2</sup>	<input type="text" value="0x8000"/>	<input type="button" value="Set"/>	-0.15	1.00
	X <sup>2</sup> - Y <sup>2</sup>	<input type="text" value="0x8000"/>	<input type="button" value="Set"/>	-0.40	1.00
	X <sup>3</sup>	<input type="text" value="0x8000"/>	<input type="button" value="Set"/>	-0.23	1.00
	Y <sup>3</sup>	<input type="text" value="0x8000"/>	<input type="button" value="Set"/>	0.17	1.00
	Z <sup>3</sup>	<input type="text" value="0x8000"/>	<input type="button" value="Set"/>	-0.16	1.00
	R <sup>4</sup>	<input type="text" value="0x8000"/>	<input type="button" value="Set"/>	-0.13	1.00
	H <sup>0</sup>			0.00	

- Write DAC-Values to FRAM
- Read DAC-Values from FRAM
- Get Dac values
- Set DAC-Values to coils

### Write DAC-Values to FRAM:

The DAC-Values will be saved to the onboard storage (non-volatile RAM)

### Read DAC-Values from FRAM:

If you want to get the DAC-Values you have saved in the FRAM, you can choose this option. Please remember, the values will only catch from the FRAM to the controller on the Shim Control Board. After this operation you have to do the next operation "Get Dac-

Values”

## Get Dac values:

This function fetches the active DAC-Values from the Shim Control Board controller to the Web page.

## Set DAC-Values to coils:

This function sets the active DAC-Values in the Shim Control Board controller to all coils.

## Apply:

This button will apply the function you have chosen with the checkboxes.

## Coil 2

On this page you can see the 8 coils which are controlled by the second Shim Control Board. The resolution of the DAC which set the current to the coils is 16 bits.

Coil:	name	DAC		Current [mA]	Ratio
	Z5	<input type="text" value="0x8000"/>	<input type="button" value="Set"/>	-0.12	1.00
	YZ2	<input type="text" value="0x8000"/>	<input type="button" value="Set"/>	-0.32	1.00
	YZ3	<input type="text" value="0x8000"/>	<input type="button" value="Set"/>	-0.21	1.00
	Z6	<input type="text" value="0x8000"/>	<input type="button" value="Set"/>	-0.13	1.00
	(X2-Y2)Z	<input type="text" value="0x8000"/>	<input type="button" value="Set"/>	-0.23	1.00
	XZ3	<input type="text" value="0x8000"/>	<input type="button" value="Set"/>	-0.37	1.00
	XYZ	<input type="text" value="0x8000"/>	<input type="button" value="Set"/>	0.04	1.00
	XZ2	<input type="text" value="0x8000"/>	<input type="button" value="Set"/>	-0.04	1.00

  

Write DAC-values to FRAM  
 Read DAC-Values from FRAM  
 Get Dac values  
 Set DAC-Values to coils

## 7.4.3 GAB/2 Interface

Since the GAB/ Backplane is a slave of the main board, the GAB specific web server functions are found on the main board web server under:

**Main-> minispec -> GAB/2 System**

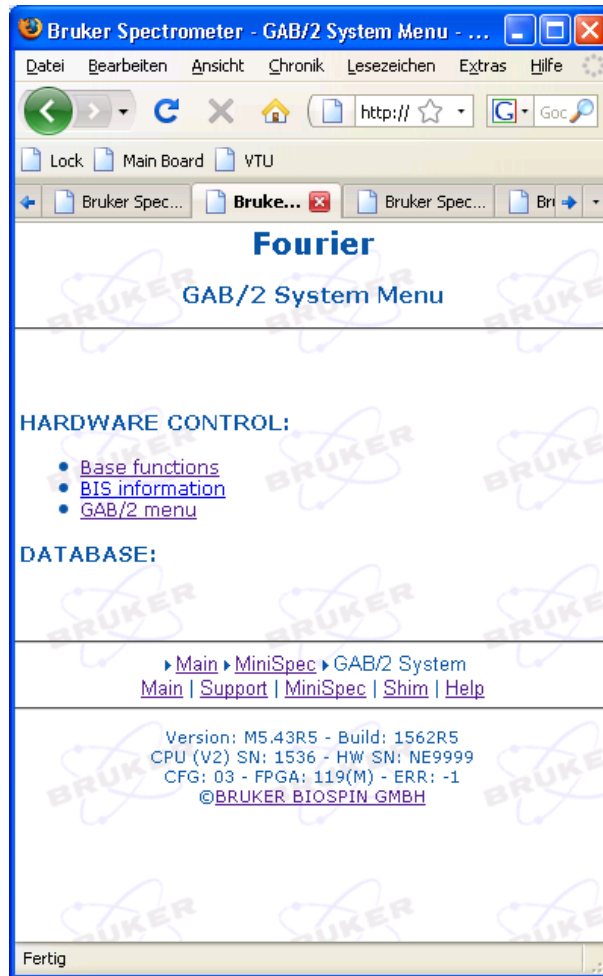

In order for the GAB/2 Backplane main board to be recognized as a Fourier component, the following entries need to be made in NAME group part of the BIS EEPROM. This is accessed via:

**Main-> minispec -> GAB/2 System -> BIS Information**

# Configuration

**NAME group:**  
Enter device identifier ("GBP": GAB/2 Backplane).

Unit:

You can check the presence of the GAB/2 Backplane and the GAB/2 Gradient amplifier using:

**Main-> minispec -> GAB/2 System -> Base functions**

### GAB System Configuration:

GAB System	Device Status	Connection Status	Operation
GAB System Backplane	present	connected	<input type="button" value="Check"/>
GAB/2 Board	present	connected	<input type="button" value="Check"/>

You can check is an LVDS link is present using

**Main-> minispec -> GAB/2 System -> GAB/2 Menu -> GAB/2 Control**

GAB/2 Command	
GAB Mode	<input type="button" value="ON"/> <input type="button" value="OFF"/> pending (waiting for LVDS link)
GAB/2 Status	
Relay Mode	off
Analog Path	off
GCON Parity Check	inactive
GAB/2 Backplane Firmware Version	V00.04
GAB/2 Backplane FPGA Version	V0.01

## 7.4.4 Lock Board

In order for the lock main board to be recognized as a Fourier component, the following entries need to be made in NAME group part of the BIS EEPROM. This is accessed via:

## Main -> minispec -> BIS Settings

NAME group:  
Enter device identifier ("MQ1": mqOne).

Unl

Apply NAME Changes

The main information and setting page is found under:

## Main -> minispec -> Lock

This page is divided in 4 parts:

- properties for the pulse programmer
- the current status of the lock signal
- Fine DAC search function
- Coarse DAC sweep function

The dynamic parameters (lock power, frequency, phase, loop gain etc) of the lock panel are set by the EDLOCK table. The values circled in red are base settings that need to be set correctly for the lock to operate properly.

An explanation of the parameters and functions follows:

### Pulse properties:

pulse length (ms)	dead time (ms)	number of points	recycle delay (ms)
0.100000	0.020000	4000	1.000000
NMR frequency (MHz)	Gain (dB)	Attenuator (dB)	Magnitude Lock Lost
46.079787	80	20	100000
P-gain	I-gain	Integral Setpoint	Freq. Calibration (Hz)
0.100000	0.100000	0	125
Display Scale Factor	Field DAC Small Field DAC Wide	moving average	phase angle(deg)
2.17	647 1508	4	26.0
<input type="checkbox"/> intern = unchecked <input checked="" type="checkbox"/> extern = checked	<input checked="" type="checkbox"/> auto range		
<input type="checkbox"/> Self Test	<input type="button" value="P-Control ON"/>		
<input type="button" value="Start/Update"/>	<input type="button" value="I-Control ON"/>	<input type="text" value="operate +P +I"/>	<input type="button" value="Phase Correction"/>
<input type="button" value="Stop"/>	<input type="button" value="Control Off"/>		

DAC Value	Magnitude	real	imaginary
602	23319290	4829	7
<input type="button" value="Show"/>			

Field DAC center	Sweep width[steps]	Step size	Dwell time[ms]
2047	4000	40	500
Magnitude Max	DAC Val	Minimum Magnitude	
0	2047	100000	
<input type="button" value="Search"/>			

## Pulse length:

This value describes the time for pulses. **Default: 100 us**

## Dead time:

The dead time is the waiting time after the pulse before sampling begins. **Default: 20 us**

## Recycle delay:

This value represents the repetition rate for the pulse programmer. **Default: 1ms** (i.e. 1 kHz repetition)

## Number of points:

The number of data points averaged by the FPGA within the recycle delay. The maximum value is  $(\text{recycle delay} - \text{pulse length} - \text{dead time}) / 12.5 \text{ MHz}$ . **Default: 4000 points.**

## NMR frequency:

This is the  $^2\text{H}$  NMR frequency including chemical shift offset. There is no default as this value is set by EDLOCK.

## Gain:

This is the gain for the receiver path. 40 dB means no gain in relation to the pre-amplifier. The range is from 40dB to 106 dB. **Note** that this is NOT the gain set by the lock display panel which is a pure digital display factor. The hardware gain remains constant and

should be set such that weak solvents have sufficient signal to reach the minimum lock and search levels, and low enough not to clip or change phase with strong solvents.  
**Default: 80 dB.**

## **Attenuator:**

This adjusts the lock power level. At full power (0dB attenuation) the lock power is approximately 1mW (0dBm). The attenuator has a range 30dB in 1db steps. There is no default as this value is set by EDLOCK.

## **Magnitude Lock Lost:**

(Default 100000)

If the Magnitude of the lock signal (as seen in “show”) falls below this limit, the “LOCK LOST” button in the TOPSPIN BSMS panel will go red show a weak signal or indicate that the lock has been lost.

## **P-Gain:**

This is the proportional gain of the digital PI control. Higher Values mean tighter & faster control but also more lock noise and chance of oscillations. The lock will be stable up to values of around 0.8, but is normally set to around 0.1 by the EDLOCK table

## **I-Gain:**

This is the integral gain of the digital PI control. Higher Values mean tighter & faster control but also more lock noise and chance of oscillations. The lock will be stable up to values of around 0.8, but is normally set to around 0.1 by the EDLOCK table

## **Integral Setpoint:**

This is setpoint for the imaginary term during lock and should always be set to **0**.

## **Frequency Calibration:**

This value can be used to calibrate the Lock. This is done using a known sample. Increasing this value by 1 step will shift the 1H spectrum by approx 6Hz to the left.  
**Default Value: 125**

## **Display Scale Factor:**

This is a floating point number that scales the display gain. A value of 1.0 is equivalent to 60 dB in the BSMS panel.

## **Field DAC Small:**

The Lock is controlled by two DACs. A 12-bit coarse DAC is used for range selection and a 12-bit fine DAC which does the actual field regulation. The resolution of the fine DAC is about 0.025 Hz per DAC Step.

A DAC value 0 means maximal negative current and 4095 means maximal positive current. 2047 means zero current. When the control loop is closed, this value is under control of the lock software.

## **Field DAC Wide:**

The resolution of the wide/coarse DAC is about 50 Hz per DAC Step. When autoranging is ON (default), this value is under control of the lock software. In case of magnet drift, when the fine DAC gets to below 500 or above 3500, the coarse DAC is incremented or decremented by one step, to bring the fine DAC back nearer the center of its operating region

## Moving Average:

This is a moving average of lock monitor signal. The range is from 1 to 1000. There is no default as this value is set by EDLOCK. A value of 1 represents a bandwidth of 1000 Hz, and . A value of 1000 represents a bandwidth of 1 Hz.

---

**i** **Note** that this is used only for the display of the lock monitor and not for the regulation. The regulation bandwidth is only affected by the P & I gains.

---

## Phase angle:

This is the Phase correction for the real and imaginary part of the lock signal. The Lock Level display in the front end TopSpin displays only the real part of the signal. The imaginary part is used to regulate the field. There is no default as this value is set by EDLOCK.

## Phase Correction:

In order to be able to lock, the real part needs to be maximum and positive and the imaginary needs to be close to zero. Pressing this button automatically calculates the phase required for this condition.

## Start / Update:

Starts the pulse programmers and sets all parameters to the hardware. This is the OPERATE mode, which generates lock signal, but not yet close the control loop.

## Stop:

This stops the pulse programmer and data collection. The lock is now in STANDBY mode and no RF Pulses are generated.

## Auto Range:

In case of magnet drift, when the fine DAC gets to below 500 or above 3500, the coarse DAC is incremented or decremented by one step, to bring the fine DAC back nearer the center of its operating region. **Default: ON**

## P-Control ON:

Enables the proportional part of the control loop (-> Operate +P). The fine DAC value will be the proportional gain times the difference between the imaginary part of the signal and zero.

## I-Control ON:

Enables the Integral part of the control loop (-> Operate +I). The fine DAC value will be the integral gain times the accumulated difference between the imaginary part of the signal and zero.

When the Lock is enabled from within TopSpin it always enables BOTH the proportional and integral gain (-> Operate +P +I)

## Control Off:

Switches off the control loop, but continues pulsing and data acquisition (-> Operate).

## Standby/Operate:

This part of the Web page is a status field.

Status	Description
Standby	The Lock board is in Standby mode. No pulses are being generated, no data acquisition.
Operate	The pulse programmer is pulsing and data acquisition is active working. The PI control is OFF
+P	The PI control works with the P-Gain
+I	The PI control works with the I-Gain
Sweep on	The device is in the Sweep mode
Self test intern	The device is in the internal Self Test mode
Self test extern	The device is in the external Self Test mode

## Self Test:

The can self test the lock board by rerouting its output pulse to its receiver input. This creates a lock monitor signal of constant amplitude and almost no noise, which responds to phase and receiver gain like a real NMR signal. You may need to reduce the receiver gain, if the signal is too large.

## Internal / External:

There are two modes for the self test. In the internal mode, the modulator output is routed to the receiver input internally on-board. This can be done purely by software. In the external mode you have to physically connect the output to the input, but this has the advantage that the pulse attenuator can also be tested.

## Show

Pressing show refreshes the current values of fine DAC, magnitude, real and imaginary values of the Lock signal.

## DAC-Value:

Shows the current value of the Fine DAC. If the PI control is active, this is an indication of what the lock is actually doing. When the lock is stable, this value should be close to the centre of its operating region (ie. around 2000) and can vary by up to  $\pm 10$  counts (each count represents 0.025 Hz). When Auto-ranging is enabled, when the fine DAC gets to below 500 or above 3500, the coarse DAC is incremented or decremented by one step, to bring the fine DAC back nearer the center of its operating region

## Magnitude

This is a “magnitude” value of the lock signal and corresponds to the sum of the squares of the real and the imaginary part. Since there is no square root, taken at this point, it is strictly speaking a power value.

## Real

This is the real part of the lock signal, which is used for the lock monitor

## Imaginary

This is the imaginary real part of the lock signal, which is used for the PI control

## Search

This performs a search over the entire Fine DAC range looking for the maximum signal in the 100 Hz or so (1H) covered by this range.

The Wide DAC will stay constant during this search function. It searches the range given by “**sweep width**” (default 4000) around the “**Field DAC center**” (default 2047) value in “**steps**” (default 40) number of steps, waiting dwell time (default 500ms) at each step.

At the end of the search (which with the above defaults takes about 20 seconds), the maximum signal found is displayed in “**Magnitude Max**” and the DAC value shown in **DAC val**. A search is considered successful, if the maximum value is above the value set in **Minimum Amplitude (Default 100000)**, and if the corresponding DAC value was between 500 and 3500 (i.e. not too close to its limits). If the search was unsuccessful, the “AUTO LOCK procedure of TopSpin varies the coarse DAC in steps of  $\pm 10$ ,  $\pm 20$ ,  $\pm 30$ ,  $\pm 40$  and  $\pm 50$  in order to find a good lock. If there still is no good lock result, the automatic routine fails, and the lock has to be found manually using the sweep mode.

## Sweep

This function sweeps the wide DAC with a range of “**sweep width**” (default 1000, i.e. about 5 kHz range) around the currently set “**Field DAC Wide**” value, in steps of “**step size**” (default 1).

Wide Coarse too High

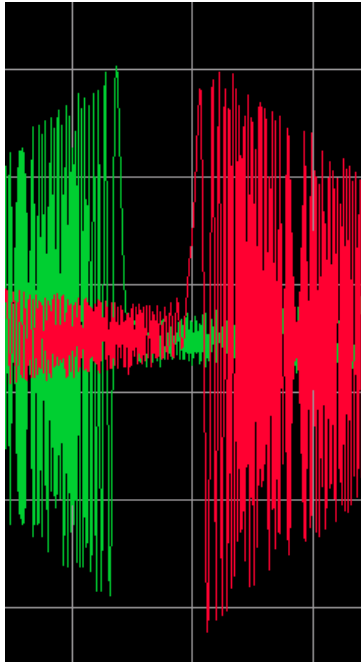

WideDAC too low

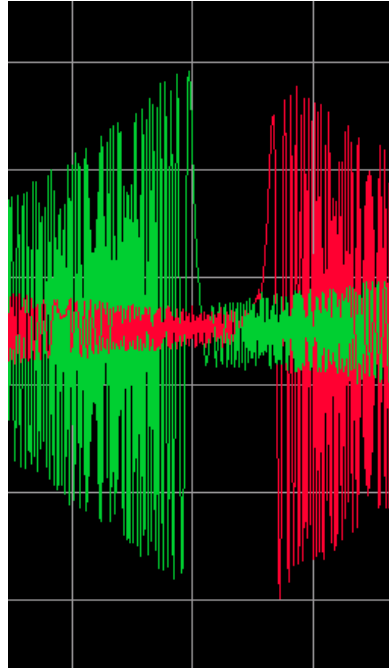

Wide DAC OK

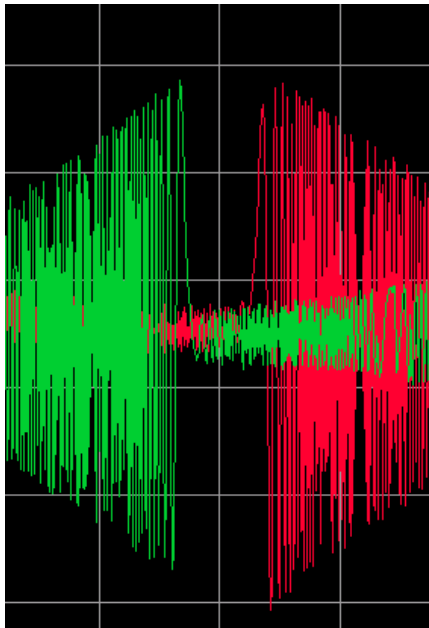

The sweep mode can also be used to check and adjust Lock Phase.

Phase wrong

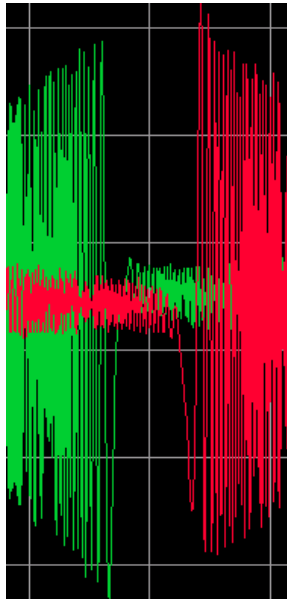

Phase Correct

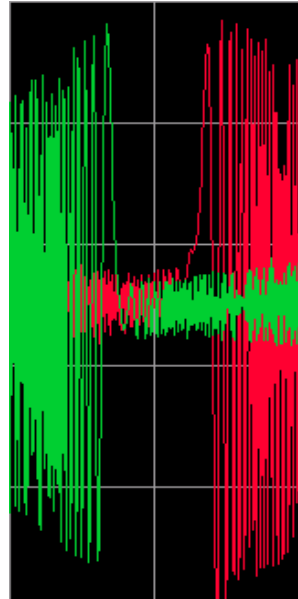

## 7.4.5 VTU

In order for VTU the lock main board to be recognized as a Fourier component, the following entries need to be made in NAME group part of the BIS EEPROM. This is accessed via:

**Main -> VTU -> BIS Settings**

A screenshot of a web-based configuration interface. It shows a section titled "NAME group:" with the instruction "Enter device identifier ('vtu' for VTU).". Below this is a text input field labeled "Unit:" containing the text "VTU". The input field is circled in red. Below the input field is a button labeled "Apply NAME Changes".

The main web page is found under:

**Main -> VTU -> Controller Parameters**

**VTU**  
VTU controller parameters

---

**PID Controller:**

Parameter description	Set value	Parameter
Proportional band	0.000000	0.500000
Integral time	0.000000	0.100000
Derivative time	0.000000	0.000000

Apply Changes

**Temperature:**

Setpoint [K]	Actual Temp. [K]
300.0	299.49

Apply Changes

**Heater:**

Heater [%]	Max [%]
0.000	100.0

Apply Changes

**Temperature control:**

Start Stop

This can be used to control the VTU independently of TopSpin, or to monitor its function. PID Parameters cannot be set here, this has to be done on a separate page (see below)

## 7.4.5.1 Changing PID parameters

This is done under :

**Main -> VTU -> PID Parameter**

**VTU**  
Upload PID parameters

---

**Current parameter table**

Temperature From [K]	Temperature To [K]	Gas Flow [%]	P term	I term	D term
250.00	350.00	0.00	0.50	0.10	0.00
0.00	0.00	0.00	0.00	0.00	0.00
0.00	0.00	0.00	0.00	0.00	0.00
n nn	n nn	n nn	n nn	n nn	n nn

The VTU can store different PID setting for different temperature ranges. Since the Fourier Probe VLC only has a narrow temperature range usually one range is sufficient.

**i** Notice: The value for **gas flow** in this table must always be **0%** since this is only used in connection with an N2 Evaporator system.

Default Values are P=1.0, I=0.07 for Gas flows of 270 to 400 l/h.

The values can either be changed via the self tune function in TopSpin (not yet implemented in V 1.0) or uploaded manually. Since the firmware always expects a whole value table, you have so upload a file, even if you only want to change one value.

1. Create a text file with the following format:

**250,350,0.0,1.0,0.07,0.0**

(in this example the temp range in °C and 1.0 and 0.07 are P and I respectively)

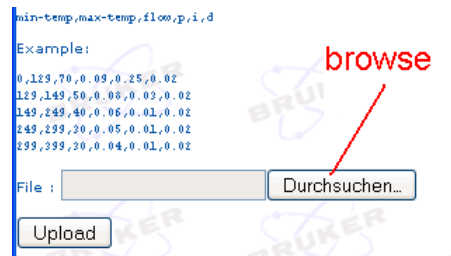

2. Select this file with the browser and press upload.

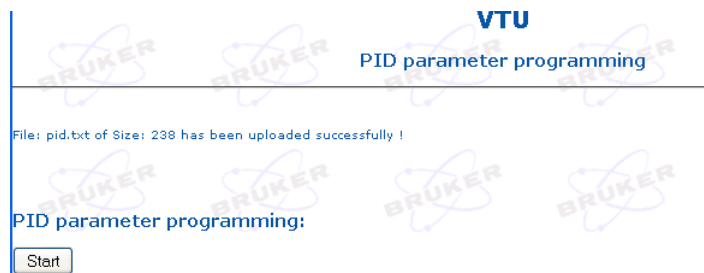

3. Press start to save the values to the EEPROM of the VTU.



This only takes a second and is completed when the following message appears:

## 7.4.5.2 Setting the Heater Protection Threshold

In case the gas supply to the probe is missing, the heater switches off when the overheat sensor reaches the threshold safety limit. This can be set under:

**Main -> VTU -> Thermocouple**

VTU Thermocouple

---

Parameter:

Number	T [K]	ADC value	Alarm
1	298.75	33600 = 0.064V	OK
2	301.82	33700 = 0.071V	OK

temperature of sample sensor  
temperature of overheat sensor

Overheat:

Overheat Temperature [K]

473.0

overheat threshold (°C)

Modify

### 7.4.5.3 Calibrating the Thermocouple

A 2 point correction (e.g. Ice water & Liquid N2) of the thermocouple reading can be done under:

**Main -> VTU -> Thermocouple**

Calibration:

Number	Actual Temperature [K]	Measured Temperature (WinAcquisit) [K]
1	77.00	77.00
2	273.30	273.30

Modify

### 7.4.6 Peripheral Control

Since peripheral control is a slave of the VTU, the specific web server functions are found on the VTU main board web server under:

**Main-> VTU -> Peripheral Control**

**VTU**  
Peripheral Control Menu

---

**HARWARE CONTROL:**

- [Base function](#)
- [BIS information](#)
- [Lift Control](#)
- [Spin](#)
- [Gas Flow](#)
- [Helium Level Sensor](#)
- [Board and Shim temperature](#)

## 7.4.6.1 Setting the Lift Parameters

When the sample lift is activated, the lift air valve is slowly opened from “**start%**” to “**stop%**” in steps of “**step**”, pausing “**time**” x 32ms at each step. Typical default values for an input pressure of 4 bar are shown in the example below. You can slow down the lift by increasing the time per step or reducing the step size. In order to save these values to the non volatile memory of the board, press “save to NVRAM”.

The lift can be tested from the web pageside using the up/down toggle function

The screenshot shows the 'VTU Peripheral Control Board' web interface. Under the 'Lift:' section, there are two radio buttons for 'Direction': 'Up' (selected) and 'Down'. For the 'Up' direction, the 'Start [%]' is 20 and the 'Step' is 20. For the 'Down' direction, the 'Stop [%]' is 55 and the 'Time' is 1. Below these fields are two buttons: 'Save to NVRAM' and 'GO'. At the bottom, there is a 'Sample Up / Down' section with a dropdown menu set to 'DOWN' and a 'Get' button.

## 7.4.6.2 Setting the Spin Parameters

When the sample spin is activated, the spin air valve is slowly opened with “**offset%**” and holds this value for a time given by the number of ticks (in the example below 3 x 30 x 32 ms = approx 3 seconds) before beginning the PI control. Typical default values for an input pressure of 4 bar are shown in the example below.

The starting value of the air valve setting should be close to the value that the PI controller finally settles down to. This value can be read out under “Control PWM value (%)” and should then be entered to “offset%”.

In order to save these values to the non volatile memory of the board, press “Apply Changes”.

The spin can be tested from the web page using the start/stop toggle function.

**VTU**  
Peripheral Control Board

---

**Spin:**

Spin frequenz:  Start Set Spin frequenz[Hz]  **target spin frequency**  
 Stop

Get Spin frequenz   **actual spin frequency**

Get Spin Voltage   **voltage of spin sensor**

Spin DC Voltage Counter	<input type="text" value="10"/>	<b>safety thershold counter</b>
Sample Down Threshold Voltage	<input type="text" value="0.35"/>	

**safety threshold voltage**

Control: PWM Value [%]   **current % air valve setting**

Offset[%]	<input type="text" value="30.99"/>	<b>initial valve setting when spin starts</b>
P-factor	<input type="text" value="20.00"/>	
I-factor	<input type="text" value="2.00"/>	<b>proportional gain</b>
PostDelay in Ticks of time constant	<input type="text" value="3"/>	<b>integral gain</b>
time constant On Tick = 32ms	<input type="text" value="30"/>	<b>delay before control starts</b>

### 7.4.6.3 Setting the Spin Safety Threshold

The spin has a safety function that shuts the spin off as soon as the Lift is turned on either manually or during the initialisation of the sample changer. In order to do this, the analog sensor that monitors the spinner has to be calibrated. It has three voltages for the three possible states:

No spinner	(typically 0.1 to 0.6V)
Black	(typically 0.6 to 2.5V)
White	(typically 2.5 to 4.5 V)

Since the values vary between shim stacks and also depends somewhat on the spinner type, it is necessary to calibrate this value. Usually this only has to be done once at

installation.

1. Remove sample or activate the sample lift and note down the "empty" Spin Voltage.
2. Now insert or lower the sample and switch the spin on (either from the BSMS panel or from the web server)
3. Repeatedly read the Spin Voltage and note down the two values that can be read while the sample is spinning.
4. Now set the "sample down threshold voltage" to about half way between the lower of the two "black/white" spin voltages, and the "empty" spin voltage.

You can test if everything is set correctly. The spin should not cut off during normal operation, but should cut off immediately when the lift is activated.

---

**i** Note: The "Spin DC Voltage Counter" sets the number of times the value has to be below the threshold, before the safety shut off is activated. It should be set to 10 to avoid the spin cutting off on a single bad reading.

---

**i** Note: When the spin safety has been triggered, the spin has to be restarted manually, when the lift air has been turned off.

---

#### 7.4.6.4 Calibrating and Measuring the Helium Level

---

When the measure button is pressed, the system lets a fixed measuring current flow through the measurement sensor for a time given by  $\text{runtime} \times 32\text{ms}$ . The default is  $100 \times 32\text{ms}$ , i.e. 3.2 seconds.

After this time has elapsed, you can press "get value". If the system has been properly calibrated, this will show the helium fill level in %

**VTU**  
Peripheral Control Board

---

**Helium Level Sensor:**

runtime in ticks[32ms],  
max Value = 200

Helium Level[%]

---

**Helium Level Calibration:**

1.) Insert the calibration resistor  
2.) Press measure to read value  
3.) Press corresponding get value Button

Helium: Full Level  
[Voltage]

Helium: Low Level  
[Voltage]

## To calibrate the Helium Level Sensor :

1. Insert the “full” Level calibration standard
2. Press “measure”
3. Wait minimum for the required time (see above)
4. Press “get value” at the corresponding field. This shows the voltage across the measurement resistor. For **full**, this should be **zero volts** (except for ECL 00 Peripheral Control Boards, in which case this value will be about 5).
5. Repeat using the “empty” calibration standard.
6. For **empty**, this should be around **6 volts** (except for ECL 00 Peripheral Control Boards, in which case this value will be about 28).
7. Press “Write to NVRAM”.

## Helium Level Correction (ECL00 Peripheral Control Boards only)

ECL00 Peripheral Control Boards require an offset correction of 7%. This is entered in the section below the helium level calibration:

## Helium Level Correction

factor                      offset

1.00                      7.00                      Set

For later boards\*, this is not necessary and the setting should be:

## Helium Level Correction

factor                      offset

1.00                      0.00                      Set

\* in order to find out which version of board your system has, check the Firmware level of the Peripheral Control Board. V21 or lower is ECL00 and requires the calibration correction; all higher versions do not need the correction.

Function	Parameter	Method
BeAlive	Be alive	Get
Version	0.020	Get
LED	0x00	Set

### 7.4.6.5 Monitoring the Console and Shim Stack Temperature

**VTU**  
Peripheral Control Board

---

**Temperature:**

Board temperature    31.00                      Go

Shim temperature    22.02                      Go

## 7.5 Additional Test Applications

The Fourier has some additional test applications the route certain RF signals back to the receiver in order to check if all the RF paths are working. These tests are based on the minispec software which is routinely installed with Fourier PCs.

The minispec Fourier Test Applications are found under:

C:\program files (x86)\Bruker the minispec\service\_only\fourier test applications

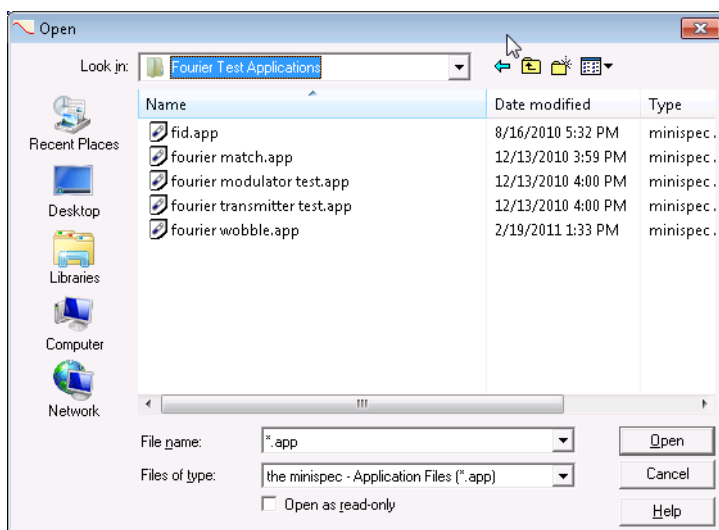

### FID.app

acquires an fid independently from topspin. Pulse length & frequency etc can be adjusted under "settings". TD, SWH are fixed for this test.

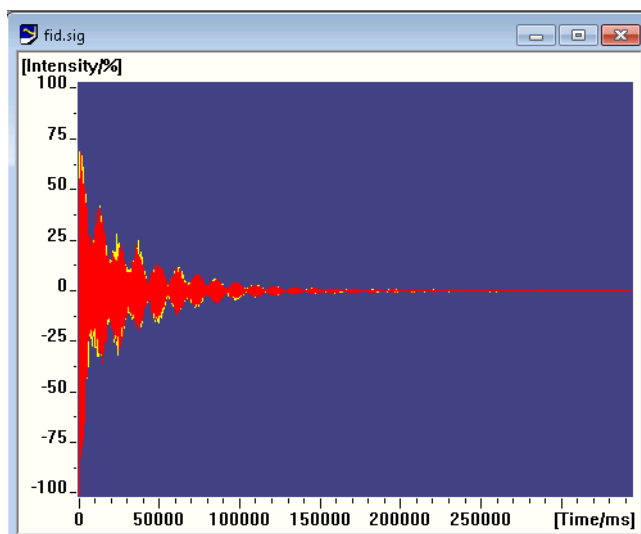

## Fourier modulator test.app

Feeds the modulator signal back to the receiver and tests if a pulse is being generated.

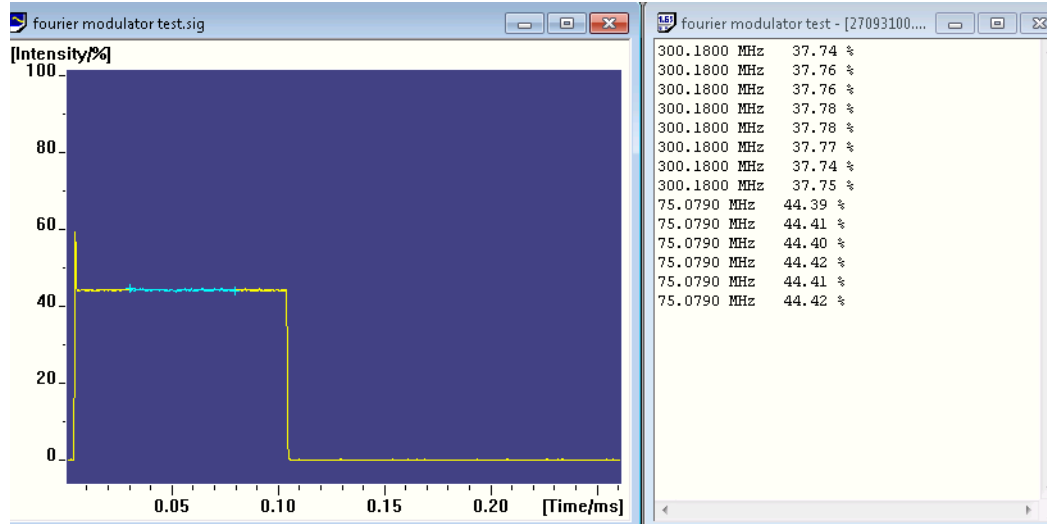

The measurement is repeated 20 times and should give stable intensity results. This can be done both for 1H and for the C13 channel. Select the right channel by changing the "observe nucleus" under "instrument settings".

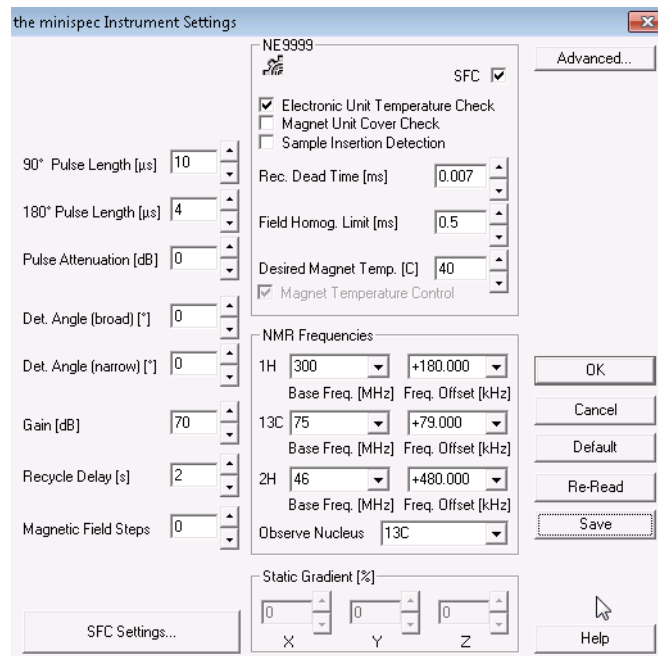

## Fourier modulator test.app

Feeds a small amount of the transmitter signal back to the receiver and tests if a pulse is being amplified. You can see the difference to the modulator signal by the rise time at the beginning. The signal intensity should be similar, but due to the variations of components cannot really be used to accurately measure the power.

The measurement is repeated 20 times and should give stable intensity results. This can be done both for 1H and for the C13 channel. Select the right channel by changing the "observe nucleus" under "instrument settings"

**i** Note: some oscillations on the top of the signal are normal and are caused by alias effects.

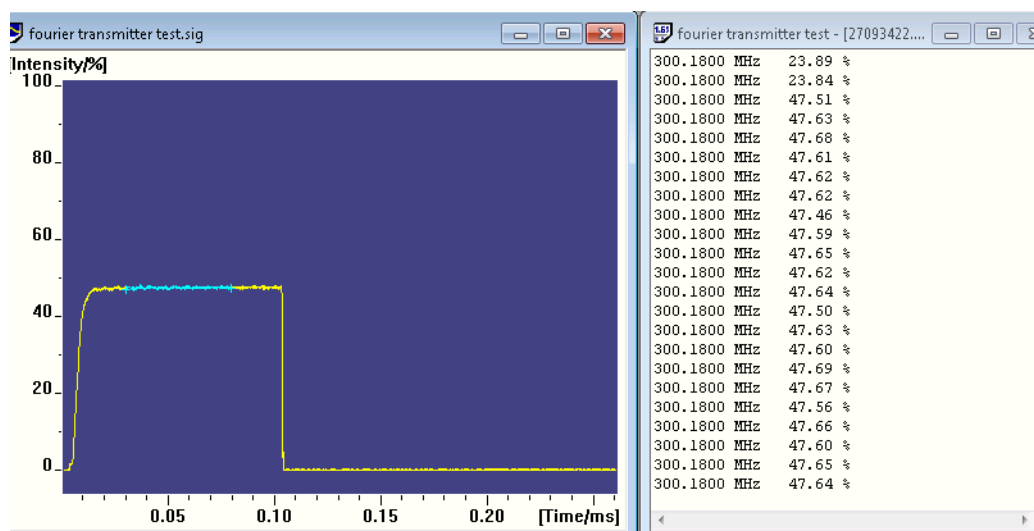

## Fourier wobble.app

Since the "wobb" routine doesn't work with the Fourier, this app creates a similar wobble curve showing the resonance of the probe:

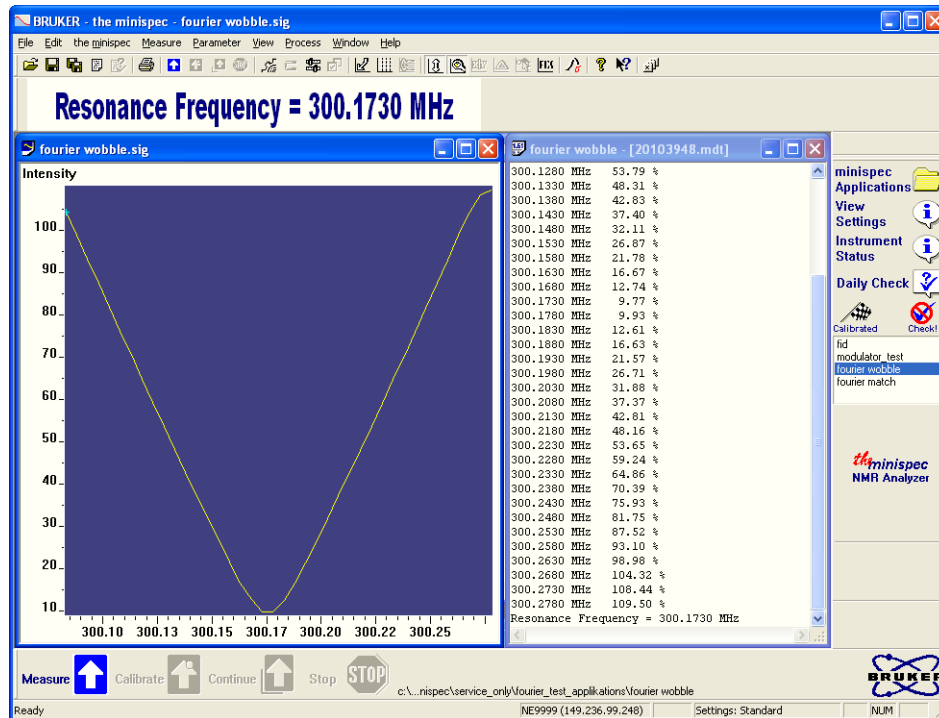

**i** Note: The wobble routine is not very accurate and is NOT intended for adjusting the tune and match on the probe. This is factory adjusted and needs no adjustment in the field. The wobble routine is intended more for a quick check to make sure that cable, preamps and probe are functioning.

## Fourier match.app

Gives an indication of the reflected power at a given frequency:

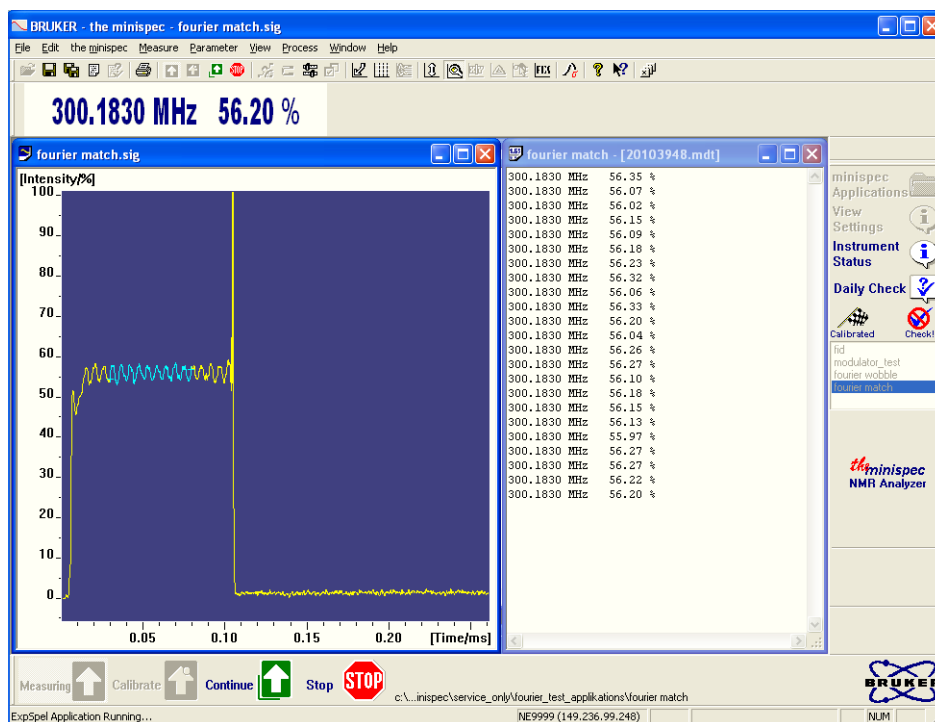

**i** Note: The values on the scale are arbitrary and do not represent the reflected power in %.

# 8 Pulse Programming

## 8.1 General Principle

---

The complete pulse programmer of the Fourier is implemented in the FPGA of the main board. This imposes some restriction on the variability and size of the pulse programs for this system. For example, there are no possibilities for branching in the pulse program. The pulse program can start due to an external trigger but once it started, it is not possible to halt/resume the program by to external triggers like the MAS signal. Another restriction is that RF phases can only be switched by 90° in a running experiment. This limits the phase cycles to the values, 0, 1, 2 and 3.

Unfortunately, it was not possible to use the output of the Topspin Avance compiler as an input for the Fourier pulse programmer due to a completely different topology. Therefore a different approach had to be used.

In addition to that, the console must also work with the miniSpec software because the same hardware is used as a high end miniSpec.

The solution is that the pulse program language for the Fourier is XML based. Instead of using the output of the Avance pulse program, only the pulse program parameters are extracted and an internal pulse program on the Fourier main board is started. As a consequence, for each Avance pulse program there must be a Fourier XML pulse program which generates exactly the same RF output. Both programs must have the same name. Starting the Avance pulse program loads the respective Fourier pulse program into the Fourier pulse programmer, sends the parameters like delays, pulse lengths and amplitudes, spectrum width, etc., to it and finally starts the experiment. The FIDs are sent to the workstation via Ethernet using the same CORBA protocol as the DRU on the Avance system.

The advantage is that the complete infrastructure of TopSpin can be used like ased, NMRSIM, graphical pulse program display, the complete parameter handler, Cortab and PowerCheck. The operator works in the TopSpin environment only.

The disadvantage is that two pulse programs have to be written which must be perfectly synchronized. Any change on the Avance pulse program only takes effect on the experiment if the Fourier pulse program is changed as well. Bruker delivers a set of well tested pulse programs for the Fourier to cover the intended use of the Fourier spectrometer.

## 8.2 Structure of Pulse Programs

---

The Avance pulse program is written in a sequential form. Each delay or pulse on one channel influences the timing on the other channels. To illustrate this, the first pulses of an HMBC pulse program are used as an example.

Avance	Fourier	
All channels	Channel f1	Channel f12
d1	d1	d1
p1 ph1	p1 ph1	d31
d6	d6	d6
p3:f2 ph3	d31	p3 ph3
d0	d0	d0
p16:gp1	d36	p16:gp1
d16	d16	d16
p2 ph2	p2 ph2	d12
...	....	....
..	..	..

Table 8.1 Structure of Pulse Programs

with the definitions

“d13=p1”

“d31=p3”

“d36=p16”

To calculate the right timing for p3 on channel f2, e.g., the Avance pulse programmer must evaluate all pulses on channel f1 as well in addition to all delays. On the right-handed side, the parallel structure of the Fourier pulse program is shown. Both channels are completely independent of each other. The only synchronization is done at the beginning of the sequence. In order to achieve synchronicity throughout the complete sequence, the operator has to take care of the timing on both channels. E.g., a pulse on only one channel must be compensated by a delay of identical length in the other channel. As mentioned before, TopSpin still compiles the corresponding Avance style pulse program in order to generate all parameters correctly. As can be seen in the example above, additional delays are necessary for the synchronization of the Fourier pulse program channels. They appear as calculations in the TopSpin pulse programs.

In the pulse program text file, the complete code for the first channel is followed by that of the second one.

## 8.3 Syntax and Examples

The XML format used tags to assign code to a special function. There is always an opening and a closing tag. The code seems to be a bit complicated because all information for a pulse, gradient pulse or delay is completely defined.

### Delays:

<DELAY>

<Duration>

```

<Unit>ms</Unit>
<VarType>7</VarType>
<JcampKwd>##$D[1]</JcampKwd>
</Duration>
</DELAY>

```

As can be seen, a tag <DELAY> defines that the following information is a delay. The tag </DELAY> closes the definition. Usually, there are sub-definitions as the physical unit for the delay, e.g. Again, there is an opening tag, the information content and a closing tag. The tag <JcampKwd> indicates that this parameter is delivered by TopSpin after starting the experiment. In this case the parameter is d1.

### Incremented delays:

```

<DELAY>
  <Duration>
    <Unit>ms</Unit>
    <VarType>7</VarType>
    <JcampKwd>##$D[0]+##$INF[1]</JcampKwd>
  </Duration>
</DELAY>

```

2D experiments typically increment an evolution time from slice to slice of the 2D. The syntax is that of a normal delay. The duration itself is calculated from slice to slice by adding the delay inf1.

### Pulses:

```

<HF_PULSE>
  <Duration>
    <Unit>us</Unit>
    <VarType>7</VarType>
    <JcampKwd>##$P[1]</JcampKwd>
  </Duration>
  <Phase>
    <Unit>quadrant</Unit>
    <VarType>0</VarType>
    <Quantity>4</Quantity>
    <Val>0</Val>
    <Val>2</Val>
    <Val>1</Val>

```

```
<Val>3</Val>
</Phase>
<Atten>
<Unit>dB</Unit>
<VarType>7</VarType>
<JcampKwd>##$PL[1]</JcampKwd>
</Atten>
<Shape>
<Unit>arb</Unit>
<VarType>7</VarType>
<Quantity>0</Quantity>
</Shape>
</HF_PULSE>
```

The first tag defines the pulse duration. The next information is the phase cycle. The phase cycle is not defined at the end of the pulse program but is an integral part of the pulse definition. Please note, that the phases are written explicitly because they are fixed values for a given pulse program. So, they don't have to be extracted from the Jcamp file. The same syntax is also possible for durations or amplitudes by replacing the <JcampKw> tag by <VALUE> tags. The following information is the pulse amplitude. Once again, it is taken from the Avance pre-compiler. In this case pl1. The last information is about the pulse shape. If it is a hard pulse, the shape quantity is "0", meaning that no information is available. Otherwise, the name of the shape file has to be given here.

If the phase cycle has to be incremented in a 2D experiment, an <Inc> tag has to be used. In the following example, the phase list is incremented by 1 for each new slice of the 2D experiment.

```
<Phase>
<Unit>quadrant</Unit>
<VarType>0</VarType>
<Quantity>8</Quantity>
<Val>0</Val>
<Val>2</Val>
<Val>1</Val>
<Val>3</Val>
<Inc>1</Inc>
</Phase>
```

## Gradient pulses:

```
<GRAD_PULSE>
<Direction>
```

```

<Unit>number</Unit>
<VarType>4</VarType>
<Quantity>1</Quantity>
<Val>4</Val>
</Direction>
<Duration>
<Unit>us</Unit>
<VarType>7</VarType>
<JcampKwd>##$P[16]</JcampKwd>
</Duration>
<Gain>
<Unit>%</Unit>
<VarType>7</VarType>
<JcampKwd>##$GPZ[1]</JcampKwd>
</Gain>
<Shape>
<Unit>arb</Unit>
<VarType>7</VarType>
<Quantity>0</Quantity>
</Shape>
</GRAD_PULSE>

```

The gradient pulse is defined by its “direction”, i.e., if it is a y, y or z gradient. It has a duration, p16 in this case, and an amplitude or gain of gpz1. It is a rectangular pulse, therefore, the shape name is “0”.

## Acquisition:

```

<RESET_ABS>
<Execute> </Execute>
</RESET_ABS>

<ACQ_MULTI>
<Duration>
<Unit>ms</Unit>
<VarType>7</VarType>
<JcampKwd>##$AQ</JcampKwd>
</Duration>

```

```
<Phase>
  <Unit>quadrant</Unit>
  <VarType>0</VarType>
  <Quantity>4</Quantity>
  <Val>0</Val>
  <Val>2</Val>
  <Val>1</Val>
  <Val>3</Val>
</Phase>
<DataPoints>
  <Unit>points</Unit>
  <VarType>0</VarType>
  <JcampKwd>##$TD</JcampKwd>
</DataPoints>
</ACQ_MULTI>
```

<RESETABS> switches to LO and starts the digitizer system. The timing of the acquisition is defined by <ACQ\_MULTI>.

The acquisition duration is aq and it uses the phase cycle 0,2,1,3. TD data points are acquired. A dwell time or spectrum width is not necessary, they are derived from aq and TD.

## Loops:

```
<P_LOOP>
  <Start> </Start>
  <Counter>
    <Unit>counts</Unit>
    <VarType>4</VarType>
    <JcampKwd>##$L[4]</JcampKwd>
  </Counter>
</P_LOOP>
```

....basic cycle....

```
<P_LOOP>
  <Stop> </Stop>
```

</P\_LOOP>

Everything between the first and the second <P\_LOOP> structure is repeated 14 times.

## Channel assignment:

The complete 2 channel pulse program needs to know which pulses belong to which channel. Therefore, tags to define one complete channel are also necessary. The frequencies and transmitter paths for the channels are defined by edasp. The first channel is always f1, i.e., the acquisition channel.

```
<?xml version="1.0"?>
```

```
<PlsSetup>
```

```
<pulses>
```

```
code for channel f1....
```

```
</pulses>
```

```
<pulses>
```

```
code for channel f1....
```

```
</pulses>
```

```
</PlsSetup>
```

<PlsSetup> </PlsSetup> declares the text in between to be the pulse program.

<pulses> </pulses> defines the text in between to belong to one channel.





# Wiring Schedules

V 1.4

**Fourier 300 Verdrahtungsplan 2**

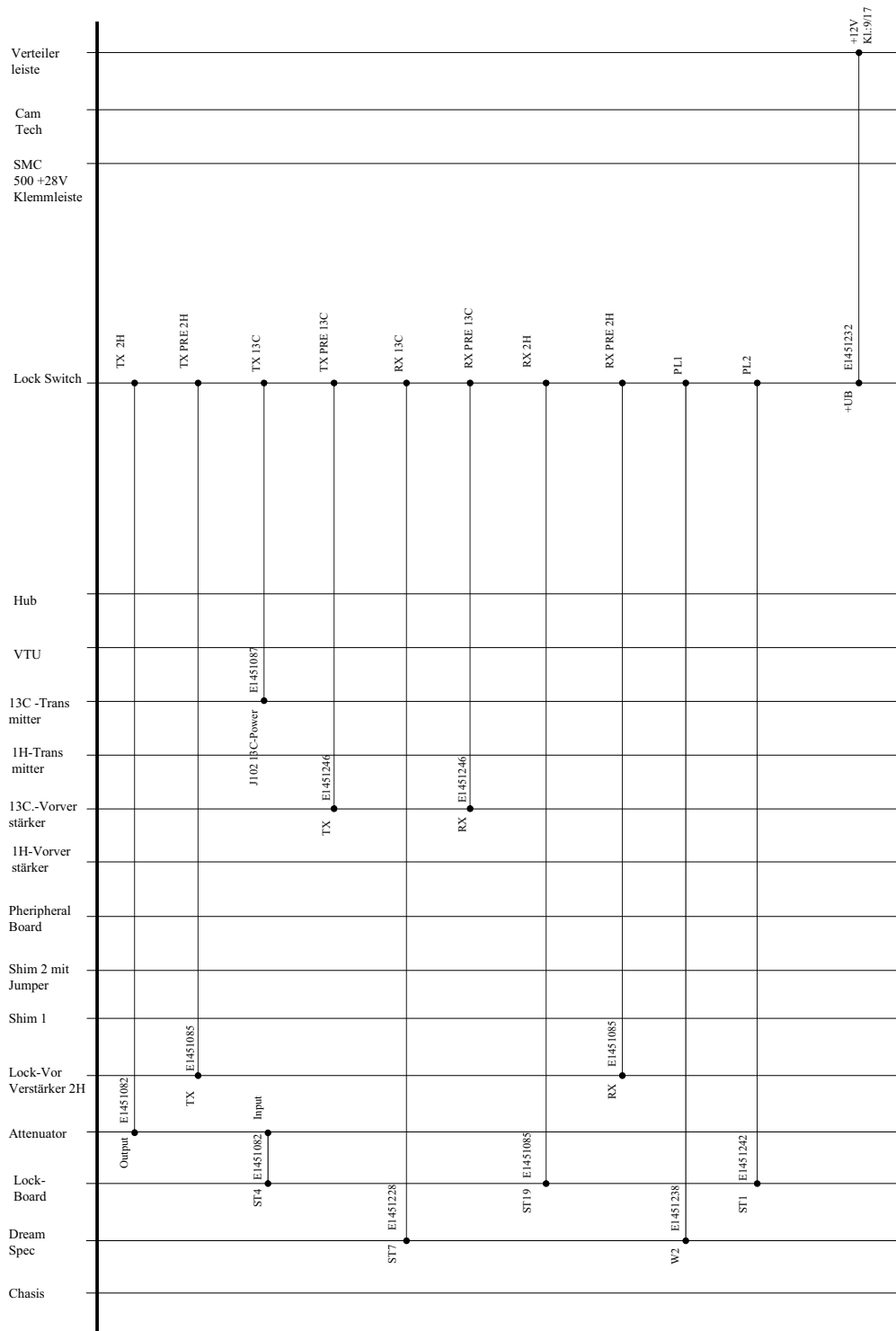

V 1.4

**Fourier 300 Verdrahtungsplan\_3**

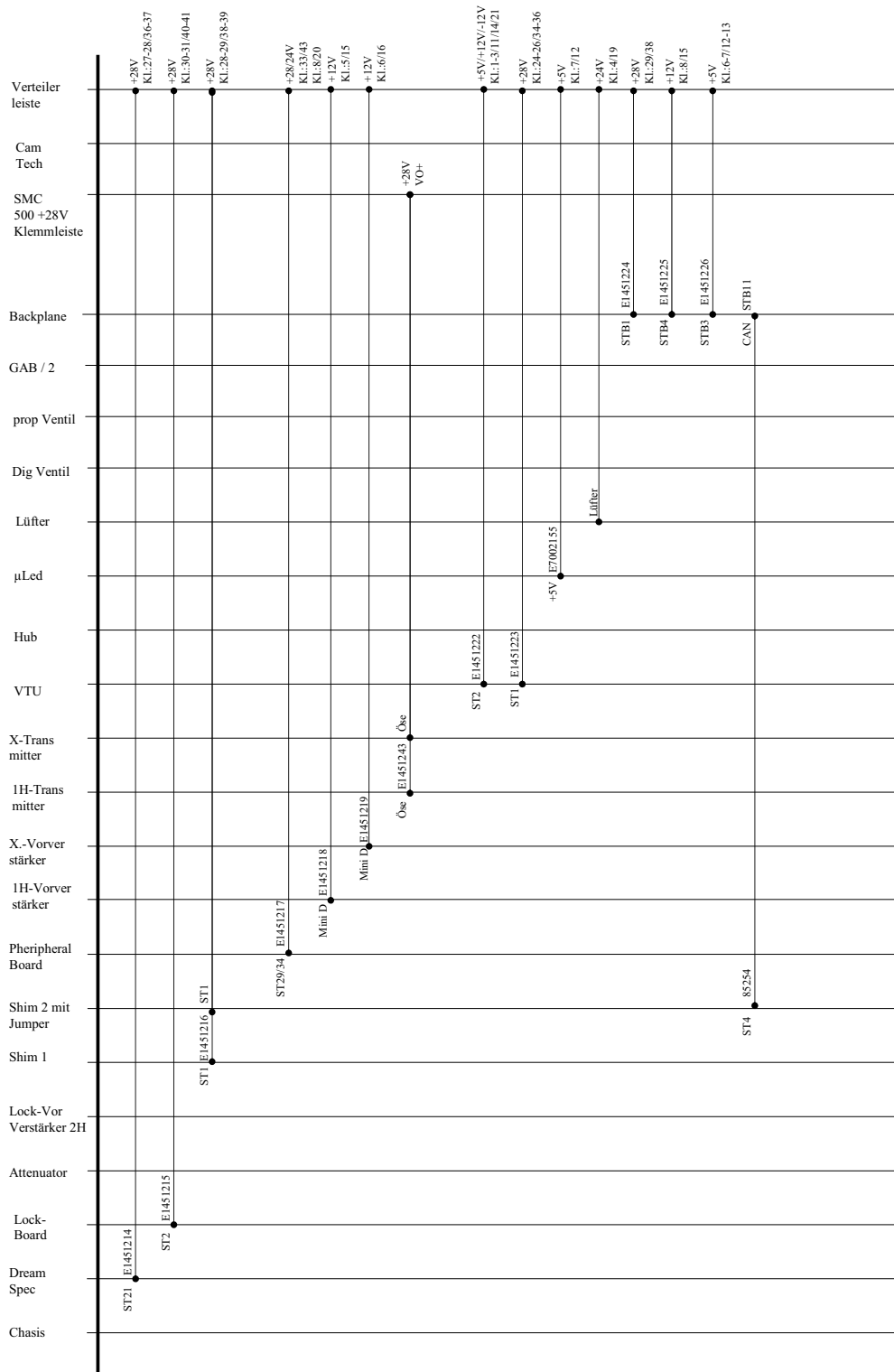

# Wiring Schedules

V 1.4

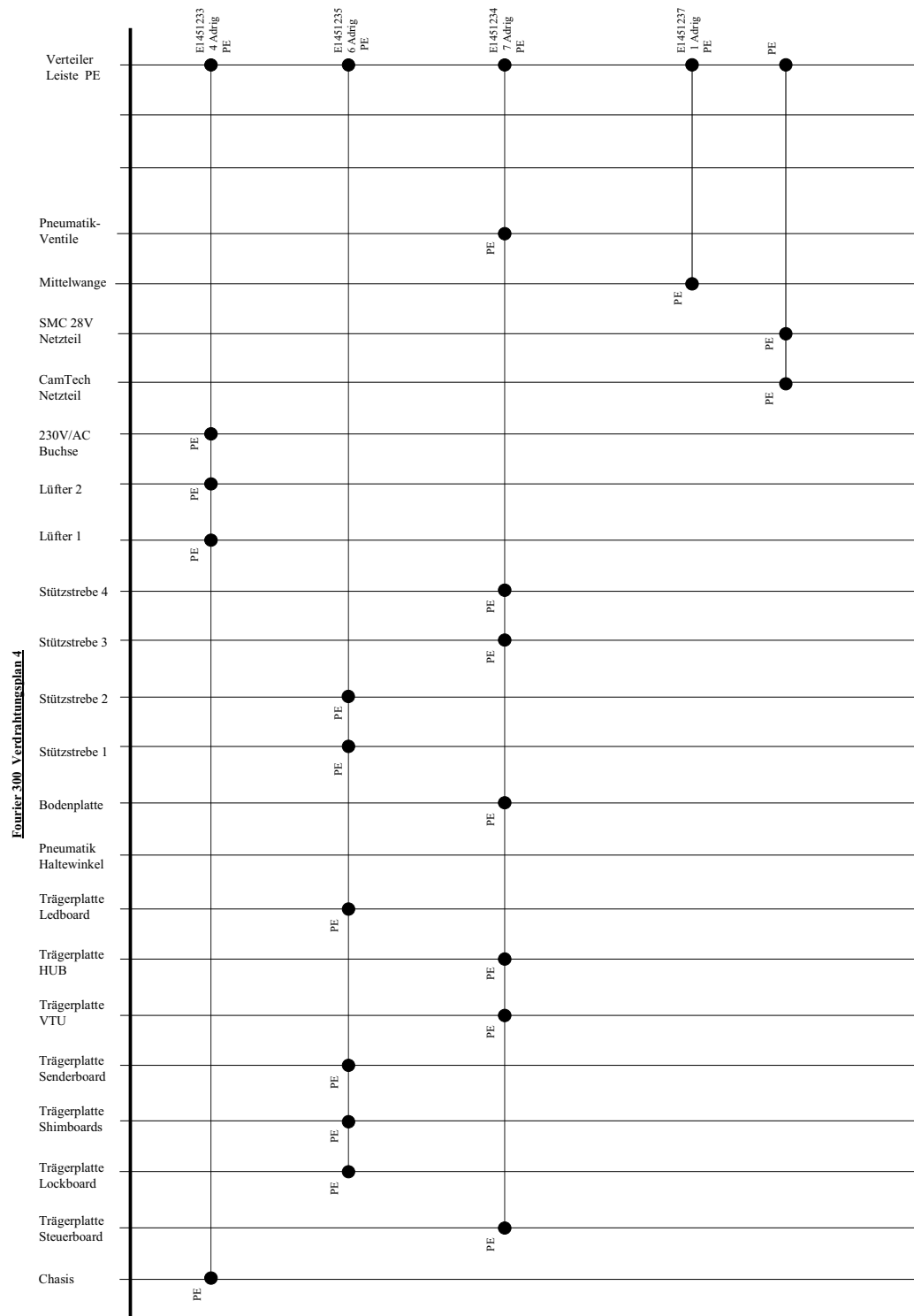

## Terminal Diagram

T

21.02.2011

KONSOLE EINHEIT 300MHZ  
(E1451100)  
KLEMMENPLAN

FOURIER 300

LINKE SEITE		FRONTANSICHT DC/VERTIKAL KLEMMLEISTE		RECHTE SEITE	
SAP-KOMPONENTENBEZEICHNUNG SAP-TEILENUMMER	SAP-KABELBEZEICHNUNG SAP-TEILENUMMER	SAP-KABELBEZEICHNUNG SAP-TEILENUMMER	SAP-KABELBEZEICHNUNG SAP-TEILENUMMER	SAP-KOMPONENTENBEZEICHNUNG SAP-TEILENUMMER	SAP-KOMPONENTENBEZEICHNUNG SAP-TEILENUMMER
RESERVE	RESERVE	RESERVE	RESERVE	RESERVE	RESERVE
RESERVE	RESERVE	RESERVE	RESERVE	RESERVE	RESERVE
RESERVE	RESERVE	RESERVE	RESERVE	RESERVE	RESERVE
SW MODE P.S. 500W 22-30V 18.5A 89064	PE 1 '0,75mm² (gn/ge)	PE 1 '0,75mm² (gn/ge)	PE 1 '0,75mm² (gn/ge)	DSPEC PNEUMATIK-VERTEILERBLOCK * DIGITAL 1804214	DSPEC PNEUMATIK-VERTEILERBLOCK * DIGITAL 1804214
VENT SCHUTZGITTER LZ 23 (11094)	KABEL SPEZ GND 300 4-ADRIG E1451233	KABEL SPEZ GND 300 4-ADRIG E1451233	KABEL SPEZ GND 850 7-ADRIG E1451234	DSPEC PNEUMATIK-VERTEILERBLOCK * DIGITAL 1804214	DSPEC PNEUMATIK-VERTEILERBLOCK * DIGITAL 1804214
DSPEC KONSOLE RUECKWAND (E1451165)	KABEL SPEZ GND 300 4-ADRIG E1451233	KABEL SPEZ GND 300 4-ADRIG E1451233	KABEL SPEZ GND 850 7-ADRIG E1451234	DSPEC KONSOLE BODENPLATTE (E1451166)	DSPEC VENTILBLOCK HALTEWINKEL (E1451137)
ST IEC APPLIANCE PLUG BU SHUTTERED (87902)	KABEL SPEZ GND 850 6-ADRIG E1451235	KABEL SPEZ GND 850 6-ADRIG E1451235	KABEL SPEZ GND 850 7-ADRIG E1451234	KONSOLE MICRO HUB BEFESTIGUNG (E7002124)	KONSOLE MICRO HUB BEFESTIGUNG (E7002124)
SHIM STEUERBOARD TRAEGERPLATTE(E1451125)	KABEL SPEZ GND 850 6-ADRIG E1451235	KABEL SPEZ GND 850 6-ADRIG E1451235	KABEL SPEZ GND 850 7-ADRIG E1451234	SIGNAL CHANNEL BODENPLATTE (E7003313)	SIGNAL CHANNEL BODENPLATTE (E7003313)
LED STEUER-BD BEFESTIGUNG (E7001092)	KABEL SPEZ GND 850 6-ADRIG E1451235	KABEL SPEZ GND 850 6-ADRIG E1451235	KABEL SPEZ GND 850 7-ADRIG E1451234	STUELERBOARD TRAEGERPLATTE(E1451128)	STUELERBOARD TRAEGERPLATTE(E1451128)
SENDERBOARD TRAEGERPLATTE (E1451127)	KABEL SPEZ GND 850 6-ADRIG E1451235	KABEL SPEZ GND 850 6-ADRIG E1451235	KABEL SPEZ GND 850 7-ADRIG E1451234	DSPEC KONSOLE STUETZSTREBE 3 (E1451163)	DSPEC KONSOLE STUETZSTREBE 3 (E1451163)
LOCKBOARD TRAEGERPLATTE (E1451126)	KABEL SPEZ GND 850 6-ADRIG E1451235	KABEL SPEZ GND 850 6-ADRIG E1451235	KABEL SPEZ GND 850 7-ADRIG E1451234	DSPEC KONSOLE STUETZSTREBE 4 (E1451164)	DSPEC KONSOLE STUETZSTREBE 4 (E1451164)
DSPEC KONSOLE STUETZSTREBE 1 (E1451161)	KABEL SPEZ GND 850 6-ADRIG E1451235	KABEL SPEZ GND 850 6-ADRIG E1451235	KABEL SPEZ GND 850 7-ADRIG E1451234	DSPEC KONSOLE STUETZSTREBE 4 (E1451164)	DSPEC KONSOLE STUETZSTREBE 4 (E1451164)

FOURIER 300  
KONSOLE EINHEIT 300MHZ  
(E1451100)  
KLEMMENPLAN

21.02.2011

FRONTANSICHT		RECHTE SEITE	
LINKE SEITE		RECHTE SEITE	
SAP-KOMPONENTENBEZEICHNUNG	SAP-KABELBEZEICHNUNG	SAP-KABELBEZEICHNUNG	SAP-KOMPONENTENBEZEICHNUNG
SAP-TEILENUMMER	SAP-TEILENUMMER	SAP-TEILENUMMER	SAP-TEILENUMMER
SCHALTNETZTEIL +5V+12V+24V 5/3/3/3A	KABEL SPEZ 600 UVERTTEILER > P.S. E1451212	KABEL SPEZ 880 UVERT->VTU	VT STEUERBOARD E7003520
SCHALTNETZTEIL +5V+12V+24V 5/3/3/3A	KABEL SPEZ 600 UVERTTEILER > P.S. E1451212	KABEL SPEZ 880 UVERT->VTU	VT STEUERBOARD E7003520
SCHALTNETZTEIL +5V+12V+24V 5/3/3/3A	KABEL SPEZ 600 UVERTTEILER > P.S. E1451212	KABEL SPEZ 880 UVERT->VTU	VT STEUERBOARD E7003520
VENT 24VDC 84CBM/H 92X92X25	schwarz GND 1*0,25mm <sup>2</sup>	schwarz GND 1*0,25mm <sup>2</sup>	VENT 24VDC 84CBM/H 92X92X25 18629
DSPEC X-VORVERSTAERKER (13C)	KABEL SPEZ 600+12V UVERT->13C VORVERS. E1451060	(schwarz ohne Strich) GND 1 * 0,25mm <sup>2</sup>	ETHERNET SWITCH 10/100 MBIT 8XRJ45 86090
DSPEC VORVERSTAERKER 300MHZ	KABEL SPEZ 750 +12V UVERT->1H VORVERST. E1451040	KABEL SPEZ 550+5V UVERT->GAB BACKPL.	DSPEC GAB/2 BACKPLANE E1451170
DSPEC TASTER STEUERBOARD	KABEL SPEZ 600 LED CTRL > P.S. 5V E7002155	KABEL SPEZ 550+5V UVERT->GAB BACKPL.	DSPEC GAB/2 BACKPLANE E1451170
DSPEC PERIPHERIE-STEUERBOARD	KABEL SPEZ 820 24/28V UVERT->PERIPH. BD E1451130	KABEL SPEZ 590 +12V UVERT->GAB BACKPL.	DSPEC GAB/2 BACKPLANE E1451170
DSPEC LOCK SCHALTER BOARD	KABEL SPEZ 710 DUBOX/BUBU UVERT->BOX E1451390	RESERVE	RESERVE
RESERVE	RESERVE	RESERVE	RESERVE
SCHALTNETZTEIL +5V+12V+24V 5/3/3/3A	KABEL SPEZ 600 UVERTTEILER > P.S. E1451212	KABEL SPEZ 880 UVERT->VTU	VT STEUERBOARD E7003520
DSPEC TASTER STEUERBOARD	KABEL SPEZ 600 LED CTRL > P.S. 5V E7002155	KABEL SPEZ 550+5V UVERT->GAB BACKPL.	DSPEC GAB/2 BACKPLANE E1451170
RESERVE	RESERVE	KABEL SPEZ 550+5V UVERT->GAB BACKPL.	DSPEC GAB/2 BACKPLANE E1451170
SCHALTNETZTEIL +5V+12V+24V 5/3/3/3A	KABEL SPEZ 600 UVERTTEILER > P.S. E1451212	KABEL SPEZ 880 UVERT->VTU	VT STEUERBOARD E7003520
DSPEC X-VORVERSTAERKER (13C)	KABEL SPEZ 600+12V UVERT->13C VORVERS. E1451060	KABEL SPEZ 590 +12V UVERT->GAB BACKPL.	DSPEC GAB/2 BACKPLANE E1451170
DSPEC VORVERSTAERKER 300MHZ	KABEL SPEZ 750 +12V UVERT->1H VORVERST. E1451040	(schwarz mit Strich) +12V 1 * 0,25mm <sup>2</sup>	ETHERNET SWITCH 10/100 MBIT 8XRJ45 86090
DSPEC LOCK SCHALTER BOARD	KABEL SPEZ 710 DUBOX/BUBU UVERT->BOX E1451390	RESERVE	RESERVE
SCHALTNETZTEIL +5V+12V+24V 5/3/3/3A	KABEL SPEZ 600 UVERTTEILER > P.S. E1451212	RESERVE	RESERVE
VENT 24VDC 84CBM/H 92X92X25	parallel 3*240Ω zwischen Kabel und Klemmleiste rot +24V 1*0,25mm <sup>2</sup>	RESERVE	RESERVE
DSPEC PERIPHERIE-STEUERBOARD	KABEL SPEZ 820 24/28V UVERT->PERIPH. BD E1451130	KABEL SPEZ 880 UVERT->VTU	VT STEUERBOARD E7003520
SCHALTNETZTEIL +5V+12V+24V 5/3/3/3A	KABEL SPEZ 600 UVERTTEILER > P.S. E1451212	RESERVE	RESERVE
RESERVE	RESERVE	RESERVE	RESERVE
RESERVE	RESERVE	RESERVE	RESERVE

FOURIER 300  
KONSOLE EINHEIT 300MHZ  
(E1451100)  
KLEMMENPLAN

21.02.2011

LINKE SEITE		FRONTANSICHT		RECHTE SEITE	
SAP-KOMPONENTENBEZEICHNUNG	SAP-KABELBEZEICHNUNG	SAP-KABELBEZEICHNUNG	SAP-KABELBEZEICHNUNG	SAP-KOMPONENTENBEZEICHNUNG	SAP-KOMPONENTENBEZEICHNUNG
SAP-TEILENUMMER	SAP-TEILENUMMER	SAP-TEILENUMMER	SAP-TEILENUMMER	SAP-TEILENUMMER	SAP-TEILENUMMER
SW MODE P.S. 500W 22-30V 18.5A 89064	KABEL SPEZ 910 +28V U-VERT. > SMC E1451213	KABEL SPEZ 960 +28V U-VERT. > VTU BD E1451223	KABEL SPEZ 960 +28V U-VERT. > VTU BD E1451223	VT STEUERBOARD E7008520	VT STEUERBOARD E7008520
SW MODE P.S. 500W 22-30V 18.5A 89064	KABEL SPEZ 910 +28V U-VERT. > SMC E1451213	KABEL SPEZ 960 +28V U-VERT. > VTU BD E1451223	KABEL SPEZ 960 +28V U-VERT. > VTU BD E1451223	VT STEUERBOARD E7008520	VT STEUERBOARD E7008520
SW MODE P.S. 500W 22-30V 18.5A 89064	KABEL SPEZ 910 +28V U-VERT. > SMC E1451213	KABEL SPEZ 910 +28V U-VERT. > SMC E1451213	KABEL SPEZ 960 +28V U-VERT. > DSPEC BD E1451223	DSPEC STEUERBOARD E1451110	DSPEC STEUERBOARD E1451110
SHIM SPULE 5V-STEUER-BOARD E1423120	KABEL SPEZ 330 +28V U-VERT. > SHIM BD E1451216	KABEL SPEZ 730 +28V U-VERT. > DSPEC BD E1451214	KABEL SPEZ 730 +28V U-VERT. > DSPEC BD E1451214	DSPEC STEUERBOARD E1451110	DSPEC STEUERBOARD E1451110
SHIM SPULE 5V-STEUER-BOARD E1423120	KABEL SPEZ 330 +28V U-VERT. > SHIM BD E1451216	KABEL SPEZ 540 +28V U-VERT. > GAB BACKPL. E1451224	KABEL SPEZ 540 +28V U-VERT. > GAB BACKPL. E1451224	DSPEC GAB/2 BACKPLANE E1451170	DSPEC GAB/2 BACKPLANE E1451170
DSPEC LOCK CONTROL BOARD E1451180	KABEL SPEZ 530 +28V U-VERT. > LOCK BD E1451215	RESERVE	RESERVE	RESERVE	RESERVE
DSPEC LOCK CONTROL BOARD E1451180	KABEL SPEZ 530 +28V U-VERT. > LOCK BD E1451215	RESERVE	RESERVE	RESERVE	RESERVE
DSPEC PERIPHERIE-STEUERBOARD E1451130	KABEL SPEZ 820 24/28V U-VERT. > PERIPH. BD E1451217	RESERVE	RESERVE	RESERVE	RESERVE
RESERVE	RESERVE	RESERVE	RESERVE	RESERVE	RESERVE
SW MODE P.S. 500W 22-30V 18.5A 89064	KABEL SPEZ 910 +28V U-VERT. > SMC E1451213	KABEL SPEZ 960 +28V U-VERT. > VTU BD E1451223	KABEL SPEZ 960 +28V U-VERT. > VTU BD E1451223	VT STEUERBOARD E7008520	VT STEUERBOARD E7008520
SW MODE P.S. 500W 22-30V 18.5A 89064	KABEL SPEZ 910 +28V U-VERT. > SMC E1451213	KABEL SPEZ 910 +28V U-VERT. > SMC E1451213	KABEL SPEZ 960 +28V U-VERT. > VTU BD E1451223	VT STEUERBOARD E7008520	VT STEUERBOARD E7008520
SW MODE P.S. 500W 22-30V 18.5A 89064	KABEL SPEZ 910 +28V U-VERT. > SMC E1451213	KABEL SPEZ 910 +28V U-VERT. > SMC E1451213	KABEL SPEZ 730 +28V U-VERT. > DSPEC BD E1451214	DSPEC STEUERBOARD E1451110	DSPEC STEUERBOARD E1451110
SHIM SPULE 5V-STEUER-BOARD E1423120	KABEL SPEZ 330 +28V U-VERT. > SHIM BD E1451216	KABEL SPEZ 910 +28V U-VERT. > SMC E1451213	KABEL SPEZ 730 +28V U-VERT. > DSPEC BD E1451214	DSPEC STEUERBOARD E1451110	DSPEC STEUERBOARD E1451110
SHIM SPULE 5V-STEUER-BOARD E1423120	KABEL SPEZ 330 +28V U-VERT. > SHIM BD E1451216	KABEL SPEZ 330 +28V U-VERT. > SHIM BD E1451216	KABEL SPEZ 540 +28V U-VERT. > GAB BACKPL. E1451224	DSPEC GAB/2 BACKPLANE E1451170	DSPEC GAB/2 BACKPLANE E1451170
DSPEC LOCK CONTROL BOARD E1451180	KABEL SPEZ 530 +28V U-VERT. > LOCK BD E1451215	RESERVE	RESERVE	RESERVE	RESERVE
DSPEC LOCK CONTROL BOARD E1451180	KABEL SPEZ 530 +28V U-VERT. > LOCK BD E1451215	RESERVE	RESERVE	RESERVE	RESERVE
DSPEC PERIPHERIE-STEUERBOARD E1451130	KABEL SPEZ 820 24/28V U-VERT. > PERIPH. BD E1451217	RESERVE	RESERVE	RESERVE	RESERVE
RESERVE	RESERVE	RESERVE	RESERVE	RESERVE	RESERVE
SW MODE P.S. 500W 22-30V 18.5A 89064	KABEL SPEZ 910 +28V U-VERT. > SMC E1451213	KABEL SPEZ 910 +28V U-VERT. > SMC E1451213	KABEL SPEZ 960 +28V U-VERT. > VTU BD E1451223	VT STEUERBOARD E7008520	VT STEUERBOARD E7008520
SW MODE P.S. 500W 22-30V 18.5A 89064	KABEL SPEZ 910 +28V U-VERT. > SMC E1451213	KABEL SPEZ 910 +28V U-VERT. > SMC E1451213	KABEL SPEZ 960 +28V U-VERT. > VTU BD E1451223	VT STEUERBOARD E7008520	VT STEUERBOARD E7008520
SW MODE P.S. 500W 22-30V 18.5A 89064	KABEL SPEZ 910 +28V U-VERT. > SMC E1451213	KABEL SPEZ 910 +28V U-VERT. > SMC E1451213	KABEL SPEZ 730 +28V U-VERT. > DSPEC BD E1451214	DSPEC STEUERBOARD E1451110	DSPEC STEUERBOARD E1451110
SHIM SPULE 5V-STEUER-BOARD E1423120	KABEL SPEZ 330 +28V U-VERT. > SHIM BD E1451216	KABEL SPEZ 910 +28V U-VERT. > SMC E1451213	KABEL SPEZ 730 +28V U-VERT. > DSPEC BD E1451214	DSPEC STEUERBOARD E1451110	DSPEC STEUERBOARD E1451110
SHIM SPULE 5V-STEUER-BOARD E1423120	KABEL SPEZ 330 +28V U-VERT. > SHIM BD E1451216	KABEL SPEZ 330 +28V U-VERT. > SHIM BD E1451216	KABEL SPEZ 540 +28V U-VERT. > GAB BACKPL. E1451224	DSPEC GAB/2 BACKPLANE E1451170	DSPEC GAB/2 BACKPLANE E1451170
DSPEC LOCK CONTROL BOARD E1451180	KABEL SPEZ 530 +28V U-VERT. > LOCK BD E1451215	RESERVE	RESERVE	RESERVE	RESERVE
DSPEC LOCK CONTROL BOARD E1451180	KABEL SPEZ 530 +28V U-VERT. > LOCK BD E1451215	RESERVE	RESERVE	RESERVE	RESERVE
DSPEC PERIPHERIE-STEUERBOARD E1451130	KABEL SPEZ 820 24/28V U-VERT. > PERIPH. BD E1451217	RESERVE	RESERVE	RESERVE	RESERVE
RESERVE	RESERVE	RESERVE	RESERVE	RESERVE	RESERVE



# 10 Maintenance and Repairs

The Console is almost maintenance free. It is recommended to regularly every 6 to 12 months) depending on the environment to check and if necessary clean the filter mat for the ventilators. The filter tray [page 135/\(1\)](#) can be removed without taking the console cover off.

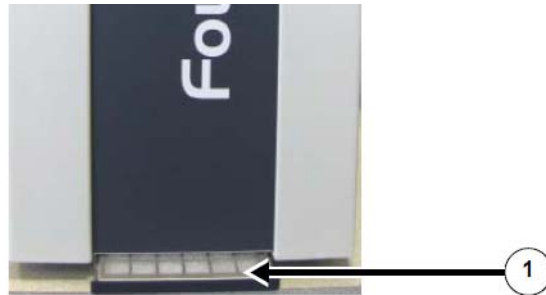

Figure 10.1 The filter tray

The filter itself can be cleaned with ordinary tap water and should be dried before replacing. Do not operate the instrument without filter for prolonged times, since dirt will build up in the electronics.

Repairs on the console should only be carried out by trained Bruker personnel.

For probe and magnet maintenance, refer to the relevant manuals.



# 11 Cleaning and Disposal

## 11.1 Cleaning

---

Do not use any detergent or other cleaning solvents. Use only water or neutral cleaning fluids. Usage of volatile cleaners like thinner or benzine may damage the surface of the unit.

- Clean the outside of the device with a soft, lint-free cloth dampened in water.

---

**i** Notice: Wait until the unit is completely dry before you reconnect the power cable.

---

## 11.2 Disposal

---

Following the end of its useful life, the device must be dismantled and disposed of in accordance with the environmental regulations.

---

**i** Installation, initial commissioning, retrofitting, repairs, adjustments or dismantling of the device must only be carried out by employees of the manufacturer or persons authorised by the manufacturer.

---

## 11.3 Safety

---

### Electrical System



### **⚠ WARNING**

#### **Electrical hazard from electrical shock!**

A life threatening shock may result when the housing is open during operation.

- ▶ Disconnect the device from the electrical power supply before opening the device. Use a voltmeter to verify that the device is not under power!
- ▶ Be sure that the power supply cannot be reconnected without notice.

### Improper Dismantling

## **WARNING**



### **Danger of injury due to improper dismantling!**

Stored residual energy, angular components, points and edges on and in the device or on the tools needed can cause injuries.

- ▶ Ensure sufficient space before starting work.
- ▶ Handle exposed, sharp-edged components with care.
- ▶ Dismantle the components properly.
- ▶ Secure components so that they cannot fall down or topple over.
- ▶ Consult the manufacturer if in doubt.

## **11.4 Dismantling**

---

Before starting dismantling:

- Shut down the device and secure to prevent restarting.
- Physically disconnect the power supply from the device; discharge stored residual energy.
- Remove consumables, auxiliary materials and other processing materials and dispose of in accordance with the environmental regulations.
- Dismantle the device by following the installation instructions in reverse.

Clean assemblies and parts properly and dismantle in compliance with applicable local occupational safety and environmental protection regulations.

## **11.5 Disposal Instructions**

---

If no return or disposal agreement has been made, send the dismantled components for recycling.

- Scrap metals.
- Send plastic elements for recycling.
- Sort and dispose of other components in accordance with their material composition.

### ***NOTICE***

#### **Danger to the environment from incorrect handling of pollutants!**

Incorrect handling of pollutants, particularly incorrect waste disposal, may cause serious damage to the environment.

- ▶ Always observe the instructions below regarding handling and disposal of pollutants.
- ▶ Take the appropriate actions immediately if pollutants escape accidentally into the environment. If in doubt, inform the responsible municipal authorities about the damage and ask about the appropriate actions to be taken.



# 12 Technical Specifications

<b>Transmit Channels</b>	
Frequency Range	5 – 405 MHz
No of Channels	2
Frequency Resolution	0.25 Hz
No of Phases	4
Timing Resolution	20 ns
Transmit Power for 1H	ca. 50 W
Transmit Power for X Channel (13C, 15N)	ca. 200W
Power Level Adjustment	0 - 60 dB in 1dB steps
Amplitude Variation	14-bit

Table 12.1 Transmit Channels

<b>Receiver Channel</b>	
No of Channels	1
ADC	50 MHz 14-bit
Effective Resolution	16.5 bits per complex pair at 1 MHz
Detection Type	Direct Digital Quad Detection
No of Phases	4
Analog Bandwidth	3 MHz
Digital Filter	FIR Filter 1kHz to 6 MHz in steps of factor 2
Max No of points per acquisition	2 x 32k (after decimation)

Table 12.2 Receiver Channel

<b>Gradient Control</b>	
No. of Channels	1 internal (GAB/2), 3 external possible
Gradient Interface	LVDS (80 MHz)

Table 12.3 Gradient Control

<b>Shim System</b>	
No of Shim Channels	20 (BOSS1 compatible)
Shim Resolution	16-bit
Shim Current	max 300 mA per channel
Shim Temperature Monitor	yes

Table 12.4 Shim System

Lock System	
Lock Nucleus	2H
Lock Type	digital P+I
Lock Speed	1 kHz
Lock Power	-30dBm to 0 dBm in 1 dB steps
Lock Resolution	0.025 Hz
Lock Range	10 kHz

Table 12.5 Lock System

Peripheral Control	
Helium Level Sensor	yes
Sample Spin Control	yes
Sample Lift Control	yes
ATMA Control	no

Table 12.6 Peripheral Control

N2 Temperature Controller	
Temperature Control	Digital PID
Temperature Range	100 to 500 °K
Temperature Sensor	PT100 or Type K Thermocouple
Temperature Stability	0.1 °
Gas Flow Regulation	0 to 1600 l/h
N2 Evaporator Control	yes

Table 12.7 N2 Temperature Controller

Software & Environment	
Spectrometer Control Software	TopSpin, minispec software
Interface	100 MB/s Ethernet
Embedded Web Server	yes
Pulse Programmes	predefined, with TopSpin variable parameters
1D Experiments	ZG, ZG30, ZGIG <sup>(1,2)</sup> , ZGPG <sup>(2)</sup> , ZGPG30 <sup>(2)</sup> DECP90, APT, APTJR, DEPT (1) GARP & GARP4 decoupling, (2) WALTZ64 decoupling

Table 12.8 Software and Environment

2D Experiments	COSYQF, COSYGPQF, COSYPH TOCSYPH, NOESYPH, NOESYGPPH HSQCGPPH <sup>(1)</sup> , HMQCGPQF <sup>(1)</sup> , HMBG- GPNDQF <sup>(1)</sup> , HMBGPLPNDQF <sup>(1)</sup>
Power Consumption	90 – 230Vac, 300-400W

Table 12.8 Software and Environment



# 13 Contact

**Manufacturer:**

Bruker BioSpin NMR  
am Silberstreifen  
D-76287 Rheinstetten  
Germany  
Phone: +49 721-5161-0  
<http://www.bruker-biospin.com>

**NMR Hotlines**

Contact our NMR service centers.

Bruker BioSpin NMR provide dedicated hotlines and service centers, so that our specialists can respond as quickly as possible to all your service requests, applications questions, software or technical needs.

Please select the NMR service center or hotline you wish to contact from our list available at:

[http://www.bruker-biospin.com/hotlines\\_nmr.html](http://www.bruker-biospin.com/hotlines_nmr.html)



# Appendix

# A

## A.1 Warning Signs

---

### C

#### Caution

Accident and material damage hazard from falling objects. ....	18
Accident hazard from contact with hot or cold surfaces on the unit. ....	21
Accident hazard from falling from ladder. ....	15
Accident hazard from movement of mechanical parts. ....	18

### I

#### Information

Hinweise, die dem Anwender die Arbeit erleichtern .....	111
---	-----

### N

#### Note

Only trained Bruker personnel are allowed to mount, retrofit, repair, adjust and dismantle the unit! .....	13
The identification and placement of warning labels should be included in the manual. ....	24

#### Notice

Material damage due to a software error. ....	15
Material damage due to the use of genuine samples during installation and maintenance! .....	16
Material damage hazard due to impacting the magnet. ....	16
Material damage hazard due to incorrect unpacking procedure. ....	45
Material damage hazard from material contact with NMR solvents. ....	22
Material damage hazard from overflow of cryogen. ....	21

### W

#### Warning

Accident hazard from asphyxiation. ....	19
Danger of injury due to improper dismantling! .....	138
Danger to life from residual electrostatic potentials! .....	17
Electrical hazard from electrical shock. ....	17, 137



## A.2 Figures

---

Figure 2.1	The Bruker Fourier 300 System.....	9
Figure 5.1	The Fourier 300 Console .....	29
Figure 5.2	Fourier 300 Console Overview .....	30
Figure 5.3	Console: Left Side.....	31
Figure 5.4	Console: Right Side .....	31
Figure 5.5	Console: Front View.....	32
Figure 5.6	Location of the Console Air Filter Tray.....	32
Figure 5.7	Console Input and Output Connections .....	33
Figure 5.8	DDS2 .....	34
Figure 5.9	DDS1 .....	34
Figure 5.10	Two Shim Boards.....	36
Figure 5.11	Lock Switch .....	39
Figure 5.12	Lock Switch Block Diagramm .....	39
Figure 5.13	Lock Switch connections & LEDS.....	40
Figure 5.14	Ventilator .....	41
Figure 5.15	Connections .....	42
Figure 6.1	Checking the DHCP Server .....	47
Figure 6.2	Result of Flock with one Solvent Peak.....	67
Figure 6.3	Gradient echo .....	72
Figure 7.1	Fixed User Specific IP Address .....	77
Figure 7.2	Power Up Jumper .....	78
Figure 10.1	The filter tray .....	135



## A.3 Tables

---

Table 2.1	Overview Installation and Operation Requirements for Personnel .....	11
Table 5.1	Preamplifiers .....	38
Table 6.1	Hard specs for the Fourier .....	75
Table 8.1	Structure of Pulse Programs .....	120
Table 12.1	Transmit Channels .....	141
Table 12.2	Receiver Channel .....	141
Table 12.3	Gradient Control.....	141
Table 12.4	Shim System.....	141
Table 12.5	Lock System .....	142
Table 12.6	Peripheral Control .....	142
Table 12.7	N2 Temperature Controller.....	142
Table 12.8	Software and Environment.....	142



## A.4 Index

---

<b>A</b>		<b>R</b>	
Accessories .....	43	RF routing .....	52
<b>B</b>		<b>S</b>	
BOSS1 Shim System .....	9	Shim Control .....	36
<b>C</b>		Solvents .....	56
Can-Bus .....	35	<b>T</b>	
cf .....	48	tty Settings .....	50
Console Air Filter .....	32	<b>V</b>	
Cortab .....	50	Variable Temperature Unit .....	35
<b>D</b>		Ventilators .....	41
Dismantling .....	138	VTU .....	35
<b>E</b>			
ETH Addresses .....	50		
<b>F</b>			
Fourier 300 .....	9		
Fourier 300 Console .....	9, 29		
Fourier match.app .....	118		
Fourier modulator test.app .....	116		
Fourier wobble.app .....	117		
<b>G</b>			
GRADSHIM .....	50		
<b>H</b>			
Helium inert gas .....	24		
<b>L</b>			
Lock Switch .....	38		
Lock System .....	35		
LVDS .....	37		
<b>M</b>			
Main Board .....	34		
<b>N</b>			
Nitrogen gas .....	24		
Nuclei List .....	50		
<b>P</b>			
Power Supplies .....	40		





---

 **Bruker Corporation**

[info@bruker.com](mailto:info@bruker.com)  
[www.bruker.com](http://www.bruker.com)

Order No: Z31980

---