

SB MAS

- SB-MAS
Operation Manual
Version 001

Copyright © by Bruker Corporation

All rights reserved. No part of this publication may be reproduced, stored in a retrieval system, or transmitted, in any form, or by any means without the prior consent of the publisher. Product names used are trademarks or registered trademarks of their respective holders.

This manual was written by

Dr. Steuernagel

© U&G à^! ÁGEFJJÍ K Bruker Corporation

P/N: Z31401

DWG: 1120001

For further technical assistance for this product, please do not hesitate to contact your nearest BRUKER dealer or contact us directly at:

Bruker Corporation
am Silberstreifen
76287 Rheinstetten
Germany
Phone: +49 721 5161 6155
FAX: +49 721 5171 01
E-mail: nmr-support@bruker.de
Internet: www.bruker.com

Contents

	Contents	iii
	Index	5
1	Shipping List.....	7
2	System Description	9
3	Site Requirements	11
4	Installation	13
4.1	Installation of pneumatic connections	13
4.2	Installation of electronic connections	13
5	Introduction to MAS and CP/MAS	15
6	Operation of the SB/MAS Probe	17
6.1	Sample preparation.	17
	Description of rotors and caps available.	17
	Packing the rotors	17
	Insertion of the sample	18
	Spinning the sample	18
	Stopping the rotation.	20
	Rotor Ejection.	20
6.2	RF-tuning the MAS probe.	20
6.3	Adjusting the magic angle	21
6.4	Shimming on water	22
6.5	Adjusting the Hartmann-Hahn condition on Adamantane and fine-shimming 22	
6.6	Signal to noise determination on Glycine	24
6.7	VT operation	25
	High temperature operation	26
	Low temperature operation	26
7	Troubleshooting	29
8	Software: Pulse and AU Programs.....	33
8.1	Preliminary pulse programs	34
	hpdec	34
	cp	35

	cptossa	36
	cptossb	38
	cpseltics	40
	cpnqs	42
	solids.incl	43
8.2	AU programs	44
	angle	44
	paropt	44
9	<i>Spectra.....</i>	45
10	<i>Using the Microprocessor Controlled Pneumatic Unit with UXNMR49</i>	
10.1	Configuration of the Pneumatic Unit	49
10.2	Preparation of the Communication with the Pneumatic Unit	50
10.3	Operation of the Pneumatic Unit	51
	Sample Insertion and Start of Spinning	51
	Changing the Speed while Spinning is on	52
	Stopping the Sample Spinning	52
11	<i>Diagrams.....</i>	53
	<i>Figures</i>	61
	<i>Tables</i>	63

Index

A

Adamantan.....	21
amplifier.....	11
Amplifier requirements	11

C

caps.....	17
cross polarization	9

G

Glycine	24
---------------	----

H

Hartmann-Hahn condition	21
heater.....	13

K

KBr	21
-----------	----

M

Magic angle.....	9
------------------	---

P

pneumatic unit.....	13
preamplifier	13
proton decoupling.....	9

R

rotors.....	17
-------------	----

S

spin rate	9
spinning.....	17

T

thermocouple 13

V

VT operation..... 9

Shipping List

1

Item	Quantity	Description
1	1	MAS probehead
2	1 Kit	3 ceramic rotors with 6 KEL-F 3 boron nitride drive caps rotor packer (hand tool) tuning screw driver marker pen (black) Cap removal assembly repair declaration form Manual

	Options:	Part Number:
1	Rotor transfer system	K0218 / K0219
1	MAS sample packer vibrator	BH0363
1	MAS pneumatic unit	H2620
1	Heat exchanger for VT operation	AH0040
1	Cable & filter set	
1	Spacers	
1	Airtight inserts	
1	Sample Packer (hand tool)	K6011001 / K8111001
1	MAS adapter multi pneumatic 6x	67554

For rotor, caps, and CRAMPS inserts please refer to the sheet MAS rotors and accessories for SB probes

Shipping List

System Description

2

The SB-MAS probehead is designed to perform the following experiments:

1. MAS experiments at spin rates of up to 7 kHz with 7 mm outer diameter rotors and up to 15 kHz with 4 mm o.d. rotors.
2. Combination of MAS with proton decoupling and cross polarization from proton to any X-nucleus.
3. Multinuclear tuning range for X-nuclei from N-15 and P-31.
4. VT operation from -80°C to +120°C

Further properties of the system:

1. Sample insertion/ejection without removal of the probehead (up to 500 MHz)
2. Magic angle adjustment with micrometer screw at probe bottom
3. Built-in heater/dewar and thermocouple for VT operation
4. Optical spin rate counter with trigger signal output for rotor synchronized experiments
5. Various ceramic materials for minimum background of various nuclei

Site Requirements

3

Air requirements:

1. Free of oil and dust (filter of 0.01 microns)
2. Dew point of at least -30°C
3. 4m³/h flow of air at more than 6 bar for stable fast spinning
4. Dry nitrogen gas for low temperature operation preferably from a pressurized liquid nitrogen tank with a nitrogen boil off device, a 60 liters gas cylinder (200 bar) lasts for approximately 1 hour
5. B-VT 2000 variable temperature unit for all VT operation and a 25 liters liquid nitrogen dewar for LT operation

Amplifier requirements:

1. **DPX:**
The standard amplifier equipment with up to 50W X amplifier and up to 20W proton amplifier is not sufficient to do CP/MAS experiments. Therefore with a SB-MAS probe more powerful amplifiers are needed to allow sufficient CP and decoupling performance. The DPX will be equipped with an amplifier of up to 300W for the X frequencies and an amplifier of up to 120W for proton frequencies up to 300 MHz, 100W for 400 and 500 MHz and 80W for 600 MHz.
2. **DRX:**
The standard amplifiers of up to 100W for X frequencies and up to 50W for proton frequencies are replaced with the same type of amplifiers described for the DPX.
3. **DMX:**
In the DMX the standard amplifiers provide up to 300W for X frequencies and up to 120W for proton, dependent on the frequency.

In conjunction with the above mentioned amplifiers the standard high resolution X-BB preamplifier can take pulses of up to 10 ms duration at a power level of 300W. In decoupling experiments with or without cross polarization the proton preamplifier has to be bypassed.

Installation

4

Installation of pneumatic connections

4.1

- The main air line connections from the pneumatic unit are all contained in one large assembly. It can be left mounted to the rear panel of the pneumatic unit. For connections refer to fig. 11.1 and 11.2.
- Figure 11.1 shows the connections for the so-called combi-box system. Here all air-tubes are contained in one large connector. For newer probes, each of the air tubes has to be connected separately (fig 11.2). Push in each connector until it clicks to ensure that each connection is tight.
- Additionally a connection to the VT unit is supplied, which can be used for keeping the probe RF components at ambient temperature in VT experiments. Connect the air flow which goes through the VT unit and set it to a flow rate of 100 l/hr. Use dry N2 for LT experiments to avoid icing.
- For experiments at room temperature and above bearing and drive gas connections are already connected. For LT experiments the bearing gas connection at the heater dewar has to be removed and the outlet of the heat exchanger has to be connected instead. Refer to fig. 12.3 for LT operation. For newer probes with the separated air connector, the LT setup is shown in fig. 11.4.

Installation of electronic connections

4.2

Probe/preamplifier connection

- Connect X amplifier to X-BB HPPR preamplifier module or X-BB HP-HPPR if available
- Connect X-channel of probe to X-BB HPPR preamplifier (or X-BB HP-HPPR) using a proton reject or a low pass filter
- Connect H-channel of probe to proton preamplifier first for tuning the probe and shimming on water, leaving high resolution amplifier output connected to preamplifier. For the decoupling experiments connect proton amplifier output directly to probe using a proton band pass filter
- Connect spin rate cable
- for VT operation connect heater cable and thermocouple coming from rear panel of VT unit.
- refer to fig. 11.5 for appropriate connections

Introduction to MAS and CP/MAS

5

Usually in solids NMR spectra exhibit much wider lines than in high resolution spectroscopy, because all internuclear interactions are maintained. Fortunately there are experimental methods to average those interactions. A very common technique like MAS enables to reduce the line width this far that it can be observed with a conventional high resolution NMR machine like DPX or DRX. Only a few components have to be added, i.e. a MAS probehead and a pneumatic unit to open a gate to the world of solid state NMR spectroscopy.

As most samples suitable for those measurements exhibit further interactions which are not completely averaged by MAS, namely dipolar interactions to protons, the system must also be equipped with a proton amplifier providing sufficient RF-power and maximum pulse lengths of several 100 ms length.

In addition, as in many cases the combination of MAS with sensitivity enhancement by cross polarization makes this a powerful tool, the X-amplifier has also to provide sufficient power and pulses of several ms length.

For DPX and DRX instruments the standard amplifiers used for high resolution experiments are replaced with 300 W amplifiers for the X-channel and proton amplifiers of up to 120 W for frequencies up to 300 MHz, 100 W for 400 and 500 MHz and 80 W for 600 MHz. These amplifiers allow pulses of up to 10 ms for the X-channel and up to 200 ms for the proton channel at full power.

Operation of the SB/ MAS Probe

6

Sample preparation.

6.1

Description of rotors and caps available.

6.1.1

The rotors used for MAS are made of ceramic materials. They are supplied in two different compositions, the grey ones being made of silicon nitride, the white to yellowish ones being made of zirconia. For all 4 mm systems the maximum achievable spin rate will be 15 kHz, for the 7 mm systems 7 kHz will be the maximum spin rate. The maximum spin rate in SB-MAS probes is determined by the probe itself rather than by the quality of the rotors. Due to the different lengths of the probes for the various types of magnets, the maximum achievable spinning speeds will be different. The longer the probe the higher the flow resistance in the probe tubing, and therefore inferior maximum spinning speeds.

To close the rotors several types of caps can be used. The standard caps are made of KEL-F, which can be used in a temperature range from -20°C to +50°C. This material will shrink at lower temperatures and soften at more elevated temperatures. Hence, for a more extended VT range caps made from macor or boron nitride can be used. Those materials have temperature coefficients similar to zirconia or silicon nitride. Also caps made from zirconia are available.

Packing the rotors

6.1.2

Because of the high spin rates achievable with the today technology, sample packing has to be done carefully. However for 4 mm and 7 mm some differences in the procedures have to be taken into consideration.

For 7 mm rotors:

The samples have to be ground as homogeneous as possible to guarantee a start-up of the rotor without problems.

For 4 mm rotors:

The homogeneity of the powdered sample is not as crucial as for 7 mm rotors. The reason is that the balanced mass of the high precision ceramic rotors with 4 mm o.d. is in many cases large compared to the mass of the sample packed into the rotor. An exception is, however, e.g. a heavy inorganic material like $\text{Pb}(\text{NO}_3)_2$ in a silicon nitride rotor.

Since for the 4 mm rotors the packing procedures are much less crucial, usually any procedure of filling or packing will allow to spin the rotor. Even rotors which are only partially filled will usually spin. If the sample is poured (i.e. loosely filled) into the rotor it will immediately pack on starting the rotation and automatically balance the rotor.

To guarantee a balanced 7 mm rotor it has completely to be filled. Therefore, if the amount of sample is not sufficient, or if the remaining grain size of the sample for evenly packing of the rotor is too large, it is possible to mix the sample with a chemically inert material containing no NMR-active nuclei being of interest for the actual sample like silica, alumina, or gypsum. In addition, spacers from KEL-F or boron nitride are available which allow to reduce the space available for the sample itself and fill the remaining space in the rotor with some balanced mass. For small amounts of sample as well as for air sensitive samples inserts are provided which can be filled separately with only one third of the usually necessary amount of sample. The advantage is that in these cases the rotors will always spin and that the sample is centered in the homogenous part of the coil, the disadvantage is of course a reduced signal intensity. There are a lot of more tricks to get difficult samples to spin, which are summarized in chapter 8 (trouble shooting).

To evenly pack the rotor a small amount of sample can be filled into the rotor and then stuffed using the packer supplied with the rotor-set. This procedure has to be repeated until the rotor is filled such that the cap just fits into the rotor. It is essential that the cap is pushed in all the way and that no gap is left between the top of the rotor and the collar of the cap. Also, there must not be any loose particles of the sample between the top layer of the sample and the cap. The cap has to fit tightly and should only be removable with some effort. If it is too loose, it can be lost during insertion or ejection or even during spinning.

Insertion of the sample

6.1.3

⇒ ***Probes with proton frequencies higher than 600 MHz require a different procedure to insert the sample.***

For the proper shift of the pneumatic unit please refer to chapter 11 (Using the microprocessor controlled pneumatic unit).

To make sure that the rotor will properly drop into the stator press the EJECT button on the pneumatic unit first. This will set the stator into a vertical position and make sure that a rotor which might be inside the probe will be ejected.

After the eject air is on (and removal of a rotor which has been in the probe) press STOP. Then the packed rotor can be dropped into the probe via the transfer tube with the cap up. Close the insertion tube and press the button INSERT. This will automatically set the stator into the magic angle position after 10 seconds, if the pneumatic unit is operated in AUTOMATIC mode. In MANUAL mode you have to press the STOP button again. There is also a possibility to operate the pneumatic unit from your host computer. For this, please refer to the UXNMR manual.

Spinning the sample

6.1.4

You can start spinning the sample by setting the desired spin rate and pressing the GO button on the control panel. In case the rotor does not reach the desired spin rate in the AUTOMATIC mode, the rotor has to be spin up in the MANUAL mode.

For manual spinning of the **7 mm rotors**: Using 250 mbar bearing pressure (BP) and 100 mbar drive pressure (DP) must give above 700 Hz spin rate. If this is impossible, stop the rotor, eject and repack it. After repacking you can try to spin the rotor in the AUTOMATIC mode.

For spinning up **4 mm rotors** in the AUTOMATIC mode, set the start bearing pressure to about 800 mbar, the default setting of 2000 mbar is for most samples too much. This can be done by pressing the BEARING button in AUTOMATIC mode and reducing the displayed BP START to the desired value.

For **manual spinning** of the **4 mm rotors**: Using 800 mbar BP and 150 mbar DP must give above 2.5 kHz spin rate. If not, slowly decrease BP to (100 mbar and immediately increase BP once the rotor accelerates. Standard samples will easily spin in a 4 mm system, problems can be encountered for conductive, liquid, or very heavy samples.

The table below gives bearing and drive pressures together with spinning speeds that should typically be possible to be reached under these conditions.

Dependence of Spinning Speed on Drive Pressures in SB-MAS Probes

Table 6.1. PH MAS200-400SB BL4

BP (mbar)	DP (mbar)	f (kHz)
2300	280	4
2400	370	5
2500	510	6
2800	790	8
3000	1180	10
3000	1820	13
3000	2280	15

Table 6.2. PH MAS200-400SB BL7

BP(mbar)	DP (mbar)	f (kHz)
1500	480	3
2000	740	4
2500	1070	5
3000	1380	6
3000	1820	7

The values have been recorded using the microprocessor controlled pneumatic unit H2620 together with the PH MAS air hose accessory Z4149.

Operation of the SB/MAS Probe

For the tests standard test turbines have been used in conjunction with standard rotors.

The recorded values are mean values as orientation aid. Variations due to production will be possible.

Stopping the rotation.

6.1.5

In AUTOMATIC as well as in MANUAL operation the rotation can be stopped by pressing the STOP button. If you want to stop rotation manually from the keypad, decrease DP first, and then BP slowly, such that BP minus DP is not less than 2 bar. Once the rotation is below 2 kHz, first reduce DP to 0 and then BP to 0.

⇒ ***In VT runs make sure that the heater is off and that gas of ambient temperature is used for the bearing.***

Rotor Ejection.

6.1.6

⇒ ***Probes with proton frequencies higher than 600 MHz require a different procedure for ejecting the sample.***

After the rotor stopped press the EJECT button. The stator will switch back to the vertical position and the rotor be ejected. For this procedure the eject air pressure has to be adjusted by a little adjust knob on the rear of the pneumatic unit such that the pressure is high enough for the rotor to lift off and not too high that the cap is not damaged when the rotor knocks against the closure of the transfer tube.

RF-tuning the MAS probe.

6.2

For optimum performance of the experiment the RF circuit of the probe has to be tuned with the sample to be run inside the probe and spinning. In case of single pulse MAS without proton decoupling, only the X-channel has to be tuned, for CP/MAS experiments and experiments with proton decoupling both channels have to be tuned.

Tune the proton channel first. Connect the BNC connector of the probe channel with the proton preamplifier. Select a data set for proton observation, set „wbsw“ to 5 MHz and „wbst“ to 2k and type „wobb“. Adjust the wobble curve displayed on the screen by matching and tuning the probe such that its minimum is at Y=0 and in the centre of the X-axis. The tuning knob on the probe bottom will shift the X-position of the curve, the matching knob will shift the Y position. The wobble procedure is terminated by typing „halt“ or „stop“.

Now tune the X channel after the proton channel. Connect the BNC connector of the probe X-channel with the X-BB preamplifier that is used for the experiments. Select a data set for X observation with the appropriate frequency and preamplifier selection and type „wobb“. Set the switch to the appropriate frequency range (high, medium or low) and turn the tuning knob until the probe response is visible on the screen. As the probe could be tuned several MHz away from a previous experiment, it can be advisable to use a wobble width „wbsw“ of e.g. 50 MHz in the beginning, which can be reduced to 2 MHz for fine tuning at the end of the wobble

procedure. Again, the Y-position on the screen can be optimized by turning the matching knob, the X-position is shifted with the tuning knob. Caution: Consider that the standard high resolution HPPR preamplifier is equipped with a deuterium filter, i.e. it is impossible to neither observe the MAS probe response at the deuterium frequency of your instrument nor to use this preamplifier for deuterium NMR. To observe deuterium you have to use a preamplifier without deuterium filter, e.g. HP-HPPR preamplifier or a dedicated deuterium preamplifier. On the other hand when you have to retune the X-channel of the MAS probe over a wide frequency range and you are using the HP-HPPR don't forget to plug in the appropriate matching boxes.

Adjusting the magic angle

6.3

To adjust the magic angle a sample with an NMR line that is very sensitive to an incorrect adjustment is needed. A very convenient sample is KBr looking at the Br-79 resonance. Its resonance frequency is very close to C-13 so that no retuning of the RF-circuit has to be done when you want to perform the subsequently described set-up of C-13 cross polarization. Furthermore it is a very sensitive signal with a very short T1. Already at moderate spin rates the satellite transition will be split into side bands, which have to be as narrow as possible for the optimum setting. Alternatively the angle can be adjusted on the CO signal of the Glycine sample. This angle adjustment, however, is only accurate enough for samples with a static line width not larger than the one for CO in Glycine. Otherwise the adjustment procedure described below has to be followed.

For the whole set-up procedure (i.e. setting the angle, shimming and adjusting the Hartmann-Hahn condition) a rotor filled with Adamantane and 20 mg of KBr can be used. For the angle adjustment spin at 4-5 kHz with 7 mm rotors, for 4 mm you might want to spin faster. In this case approximately 100 scans have to be accumulated to get a signal sensitive enough for the angle adjustment. If you use a rotor, which is completely filled with KBr, the angle setting procedure can be performed in „gs“ mode on the free induction decay (FID).

Appropriate parameters for the acquisition are:

`„pulprog“=zg, „swh“=125kHz, „td“=2k, „d1“=30ms, „p1“=2µs, „p11“=3`

In „gs“ mode, go to the „acqu“ window, separate the real and imaginary part of the FID and adjust for an on resonance decay. This can be done by changing „p1“ or adjusting the field. **Make sure that the field sweep is off and remains off for all MAS experiments!**

If the angle is close to the magic angle, you will see rotational echoes on top of an exponential decay. If you are far off angle, you will only see the exponential decay. Now start to turn the micrometer screw, until the rotational echoes last for at least 4 ms.

If you use the above mentioned Adamantane/KBr-sample, you will need to accumulate some scans to have a sufficiently strong signal. For this purpose you can use the AU program *angle*. Usually 100 scans should be sufficient. Before starting the AU program, take a spectrum and adjust the phase correction constants to get a properly phased spectrum. Now start the AU program. When you answer the question with „y“ the spectrum will be displayed every „ns“ scans, when you answer with „n“, then the FID is accumulated again and again. Now change the angle setting in small steps, allowing enough time for the completion of acquisition

(and subsequent processing). The AU program can be stopped by typing „stop“ while the acquisition is in progress. Please refer to fig. 9.1 and 9.2 for comparison. Save the proper spectrum for later reference, e.g. kbr 1 1. Write down the setting of the micrometer screw at the probe bottom.

For probes with proton frequencies of 750 MHz and above the position of the screw which adjusts the magic angle can only coarsely be determined for reproducibility. This is not very critical, as the positioning of the angle in these probes is fixed and not variable.

Shimming on water

6.4

With CP/MAS experiments line widths of less than 10 Hz can sometimes be obtained, which makes it necessary to shim an MAS probe. On initial installation of an MAS probe it is a very useful procedure to shim the probe on the proton signal of water. When filling the rotor e.g. with a syringe make sure that no air bubbles are in the rotor, because this would make the sample unshimable. Drop the rotor into the probe as described above and press the INSERT button to flip the stator into the magic angle position. For this crude shimming it is not important whether the magic angle is already exactly adjusted.

Connect the proton channel of the probe to the proton preamplifier and load a parameter set for normal high resolution proton observation. Tune the proton channel of the probe first using the „wobb“ command. Run „gs“ with the following parameters:

„swh“=125kHz, „td“=4k, „d1“=1s, „p1“=1u, „pl1“=3.

Set O1 such that you can use approx. 5 kHz of resonance frequency.

Go to the „acqu“ window and look to the separated real and imaginary data of the FID. Shim for mono-exponential decay from full amplitude to minimum 30%.

The most sensitive gradients will be X, Y, and Z gradients. Optimizing those you should be able to get below 100 Hz at half height. When you have reached this store the shim file. It is also recommended to store the data set e.g. as shimmas 1 1 for later reference. After this set „o1“=0 and change the field until the FID is exactly on resonance. Alternatively you can set the field to 0 and set „o1“ to the exact on resonance frequency of water. You must then use this „o1“ value as „o2“ for the subsequent decoupling experiment.

Adjusting the Hartmann-Hahn condition on Adamantane and fine-shimming

6.5

Eject the rotor filled with water and insert a rotor filled with Adamantane. Press the INSERT button and spin the sample between 2 and 2.5 kHz. For 4 mm rotors it might be impossible to spin them up to this low speed in the AUTOMATIC mode, you can either redefine in the MAS menu, a 4 mm MAS probe as a 7 mm probe of DB type, which will allow spinning speeds up to 5 kHz using different pressure settings, or you can spin the motor in manual mode. In the first case don't forget to set the definition back to the 4 mm probe of BL type. In the case of manual operation, set the bearing pressure to about 1 bar, then 50 or 60 mbar for the drive pressure should be sufficient for this speed. After a stable rotation is reached you can switch back to AUTOMATIC mode and type GO. The currently set spin rate will be

regulated. A 7 mm rotor should be spun to 2.5 kHz in AUTOMATIC mode without any problems. In all cases listen for a clear sound coming from the sample rotation to make sure that the rotor spins properly.

Tune the proton channel in the way described above. After this connect the output of the proton amplifier directly to the probe. You have to use a proton band pass filter in this path. Connect the output of the X amplifier to the appropriate X-BB preamplifier, and connect the X channel of the probe to the same one. Insert a proton reject filter or a low pass filter into this path. Now select (or generate) a new data set which should be suitable for C-13 observation with proton decoupling, e.g. {adamdec 1 1}. Use this data set for tuning the X channel of the probe. If matching and tuning were far off, you have to retune the proton channel. After tuning set the following parameters:

„pulprog“=hpdec, „swh“=50kHz, „td“=4k, „d1“=5s, „p1“=3u, „ns“=1.

The parameters „p1“ and „p2“ depend on the hardware configuration. With B-LAX and B-LAH amplifiers you can refer to the subsequently given values. „p1“ is always used to set the power of the X channel (between 0 and 1 for the B-LAX 300), and „p2“ is used for the proton channel. For „p2“ a value of 3 dB should already give reasonable decoupling on Adamantane. Type „zg“ and do „ft“. You should see the spectrum on one scan. Now adjust the X-frequency offset „o1“ for a position in the middle of the two signals. Acquire again one scan, do „ft“ and adjust the phase correction. You can now define a plot region which contains one of the two peaks. It will be used afterwards for the AU program *paropt*. Now start the *paropt* program and change „p1“ in increments of 1u. You should end with a 90° pulse for C-13 of about 5µs. After the first run of *paropt* you end up with a value for „p1“ from which you can estimate the necessary „p1“ to get 5µs. As „p1“ is calibrated in dB, a change by +3 will increase the pulse length by a factor of 1.41 (sqrt(2)), a change by -3dB will decrease the pulse length accordingly. Have in mind that the B-LAX and B-LAH amplifiers run into saturation once you go to negative values for „p1“.

Once you have found a „p1“ setting corresponding to 5 us, you can start to set up for cross polarization. Before, store a spectrum of Adamantane with a 90° pulse and a sufficiently long acquisition time, e.g. {adamres 1 1}. If possible you can already try to improve the shimming in „gs“ mode. At a recycle delay „d1“ of 5s don't use an acquisition time (i.e. decoupling time) longer than 100 ms. Make „d1“ at least 50 times longer than „aq“.

For adjusting the Hartmann-Hahn condition create a new data set from the previous one, e.g. {adamcp 1 1}, and change the following parameters:

„pulprog“=cp, „p3“=5u „p15“=5m, „p1“= the setting found for 5u 90° pulse, „p2“=“p12“=3, „aq“=50m.

„p15“ is the contact time in the CP sequence. Accumulate one scan. If you do not get any signal you are too far off Hartmann-Hahn. Increase the proton power by 1 dB, i.e. set „p2“=2 and rerun one scan. Continue until a signal can be observed. When this signal arises from a Hartmann-Hahn transfer, the result of „ft“ and „pk“ will be a signal 90° out of phase compared to the previous spectrum and of much bigger intensity. Readjust the phase correction parameters. What you still have to do is to adjust the accurate power levels. This is most conveniently done using the AU program *paropt*. Start the program and increment „p1“ in steps of 0.1 dB. Use the last value as start value. If the result is such that the signal in the run becomes smaller repeat *paropt* by changing „p1“ in steps of -0.1 dB. Consider the value that will be used as lowest value for „p1“ in this *paropt* run, since this corresponds to the highest power. In the next run of *paropt* use the „p1“ value found for the biggest signal (i.e. which corresponds actually to the correct Hartmann-Hahn condi-

tion) and determine the proton 90° pulse „p3“, again by using paropt and incrementing „p3“ in steps of 1µs starting from 1µs. If the result is a 90° pulse longer than 5µs, you have to increase the power settings of both channels. For this you have to use smaller values for „pl2“ and then you have to repeat the „pl1“ and „p3“ adjustment procedures as described above until at least 5µs for the 90° proton pulse are achieved. Please refer to the specification sheet for the 90° pulse length which has to be used for your system.

Take a CP spectrum with sufficiently long acquisition time for later reference, e.g. {adamres 2 1}. Check the line width and the line shape. Shim for no hump and a line width which should be smaller than 10 Hz. The probe is now prepared for C-13 CP/MAS experiments, however, for testing its optimum performance, a more solid like sample has to be used instead.

In 4 mm systems at high fields, a small hump with a small signal will usually remain to the right hand side of the main signals. This signal is due to the sample outside of the coil and cannot be shimmed away. However, this kind of signal will not be visible in a real sample. The best shim is a compromise between good resolution and good line shape.

Signal to noise determination on Glycine

6.6

Because of its liquid-like behavior of Adamantane it is a very easy sample for solid state NMR. This means that the performance of the instrument has to be checked on a „real“ solid sample. Very convenient for the purpose of checking for proper C-13 CP/MAS performance is Glycine for various reasons:

The protons in this sample have a reasonably short T_1 , which allows a recycle delay of 5s and therefore a set-up can be done quickly. The CH₂-carbon (α -carbon) has a very strong proton dipolar interaction and is therefore very sensitive to decoupling efficiency. An offset in the decoupling frequency or insufficient decoupling power can easily be seen from a broadening of this signal resulting in a poor S/N ratio.

The CO carbon (carbonyl carbon) has a large chemical shift anisotropy. A slight incorrect adjustment of the magic angle will therefore be seen on this signal. Its dipolar interaction to proton is not as strong as for the CH₂ carbon resulting in a higher sensitivity to a Hartmann-Hahn mismatch. Finally this compound is readily available, cheap, nontoxic and gives a visible C-13 CP/MAS signal on only one scan.

After the Adamantane set-up, stop the Adamantane spinner, eject it and drop the Glycine spinner into the probe. Set the stator to the magic angle and spin the sample at 5 kHz. Retune the proton channel of the probe first and then carbon channel as described above.

Create a new data set from the previous one, e.g. {glycine(4/7) 1 1} and set the parameters as following:

„d1“=5s, „p15“=1ms, „swh“=31250 Hz, „td“=2188 w, (i.e. „aq“=35 ms), „ns“=4.

„pl1“, „pl2“, and „p3“ should be the same as determined for Adamantane. Set „pl12“ equal to „pl2“. Depending on the digitizer, a sweep width somewhat different from the one given above may result. Run a spectrum. Do direct „ft“ without any line broadening. Set „o1“ to the centre of the two strong lines and rerun the spectrum.

Check the width at half height of the (left) CO signal (176.03 ppm), which should be 1 tenth of the basic spectrometer frequency in Hz (e.g. 30 Hz at 300 MHz proton frequency). Reset the angle if necessary. Turn the micrometer screw clockwise (looking from the top) away from the magic angle position and then turn back to the micrometer position found for KBr. This should be the correct setting. Run the spectrum again and check. If the width is still too large but the signal is symmetric continue with the next steps and recheck later.

Because of a change in the spinning speed the Hartmann-Hahn condition has to be optimized for this speed. Do this using the AU program `paropt` monitoring the CO signal, i.e. define a plot region which only contains the CO signal. Increment the parameter „`p1`“ in steps of 0.1 dB. Use the old value as start value. If no improvement can be observed, repeat `paropt` by changing „`p1`“ in steps of -0.1 dB. Consider the value that will be used as lowest value for „`p1`“ in this `paropt` run, since this corresponds to the highest power. Use that value for „`p1`“ which gives the maximum signal.

Now everything is prepared to optimize the parameters for the proton channel during decoupling. Increment the experiment number to record a spectrum with increased power in the proton channel during acquisition. This can be done by setting the parameter „`p12`“. Usually the power can be increased by 2 to 3 dB compared to the power level used under Hartmann-Hahn condition. When you now look to the signal of the CH₂ carbon (α-carbon) (43.3 ppm) you will notice that this becomes more intense because the hump of the signal becomes smaller. This is a good indication that the decoupling power was not sufficient yet. Another parameter that is important for efficient decoupling is the decoupler offset frequency. It can be optimized also by using `paropt` but now monitoring the CH₂ carbon signal. In this case „`o2`“ should be incremented in steps of +500 Hz. As start value you can use an offset which is shifted by -5000 Hz from the original value and go to +5000 Hz offset „on the other side“. Finally you will use the value which gives maximum signal.

Now you can check the signal to noise ratio with the „`sino`“ command implemented into UXNMR. For this you have to enter limits for the regions of the signal to be determined and of the noise to be determined. The parameters are „`sigf2`“=30, „`sigf1`“=50, „`noisf2`“=130, and „`noisf1`“=150. Make sure that no side bands or spikes are in the range which defines the noise. You should use a range of about 20 ppm for the noise determination.

Store the data set for later reference.

VT operation

6.7

In MAS and CP/MAS experiments performed at either higher or lower temperatures some changes compared to experiments at ambient temperature have to be taken into account. The KEL-F caps used in standard experiments should only be used in a range from -20°C to +50°C, because they will soften at elevated temperature and shrink at low temperature. In such a situation you would always risk that they are torn off the barrel. Therefore you should use ceramic caps like the supplied boron nitride caps, but zirconia caps and macor caps are also available. For high temperature experiments you can also use VESPEL caps.

In each probe thermocouple and heater are already built in. They have to be connected to the corresponding plugs at the rear of the B-VT 2000. **The heater must not be switched on without the bearing gas being on.** For optimum performance of the B-VT 2000 the PID parameters which apply at the desired tempera-

ture have to be calibrated. Therefore, insert an empty rotor and spin it at the speed desired for the later experiment. It is important that for this calibration the same bearing pressure is used as for the later experiment. During the calibration procedure it is possible that a much higher or a much lower temperature is generated inside the probe which is probably not suitable for your sample. Therefore it is advisable to use an empty rotor for this procedure. For an accurate description of the procedure of auto tuning the B-VT unit please refer to the B-VT unit manual.

High temperature operation

6.7.1

For high temperature operation some additional cold gas should be brought into the probe and the room temperature shim system. There is one connection into the MAS probe for frame cooling, for which the air which passes through the B-VT unit can be used. This is the external socket and ball connection at the main connection hose. Furthermore you can switch on the air for the high resolution spinners. This will blow ambient air along the MAS sample transfer tube. After having adjusted the PID constants for the B-VT unit, switch the heater off, remove the empty rotor from the probe and put in your sample. Spin it at the desired frequency, and gradually bring the sample to the desired temperature. This is possible by step wise entering higher and higher values for the temperature. You should not use steps larger than 20°C, because then the regulation of the spinning speed might cause trouble. It is advisable to check the tuning of the probe RF channels when you change the temperature by more than 20°C. Before stopping the spinning because you want to change to another sample **don't forget to switch the heater off**. The bearing gas is used to bring the sample to the desired temperature, and when this air is switched off, the desired temperature can never be reached and therefore the heater will go to full heating power for some time before it is switched off by the built in safety device.

Low temperature operation

6.7.2

For low temperature operation dry nitrogen must be used because otherwise moisture in the compressed air will freeze out. For temperatures just below 0°C the air from the standard compressed air supply might be sufficient. An excellent source of dry nitrogen is a pressurized liquid nitrogen tank with a nitrogen boil off device. At least 6 bar of pressure must be maintainable; also gas must have at least 25°C when it enters the regulation unit. In case such a dry nitrogen source is not available nitrogen gas cylinders with high purity nitrogen may be used. It is recommended to have at least two of those in parallel to be able to exchange an empty cylinder during operation.

Cooling of the sample is achieved by passing the bearing gas through a heat exchanger loop which is immersed in liquid nitrogen or any other bath. For this you have to disconnect the ball and socket connector at the inlet to the dewar at the bottom of the probe. Instead of this connect the black plastic nozzle of the heat exchanger to the probe dewar. At the inlet side of the heat exchanger (ball connector) connect the tube which comes with the heat exchanger directly to the bearing outlet at the rear of the pneumatic unit and connect the socket to the ball connector at the heat exchanger.

The 25 l dewar delivered with the VT accessory holds enough nitrogen to operate at low temperature for approximately 4 hours. Furthermore you can refill this tank during operation and while the heat exchanger is in place through the LN₂ in connector.

The same precautions are valid as for HT operation, i.e. connect the air which passes through the B-VT unit for heating the probe body and switch on the high resolution spinner air. Before putting the heat exchanger into the liquid nitrogen, set the regulation valve on the top of the heat exchanger box to position 10 (cold) and let the spinner spin for a couple of minutes to make sure all tubes are dry and filled with nitrogen. Turn the valve back to position 1 and insert the heat exchanger slowly. Be careful that no liquid nitrogen spills into your shoes, on your hands or into your face. Observe the spin rate during this procedure. Have an eye on the ball and socket connection at the box of the heat exchanger. For cooling the sample turn the valve in small steps in the direction from 1 to 10. You won't see a noticeable decrease in temperature before the valve is in position 8. Within a very small touch at the valve a large portion of the air will suddenly go through the helix in the liquid nitrogen. You should not use too much cold air at the inlet to the probe because then the heater has to take a quite large current when the desired temperature is not very low.

Troubleshooting

7

1. Read the probe manual!

2. Problems with the spinner:

a) Spinner does not insert:

- make sure stator is in vertical position
- make sure cap is pushed in as far as possible, there should be no gap between cap and spinner
- check spinner marks, remove excessive marker drops
- remove the spinner which is already inserted
- check whether transfer system is properly aligned

b) Spinner does not eject:

- make sure stator is in vertical position
- increase eject pressure
- remove probe, turn upside down and shake

c) Spinner does not start:

- check drive and bearing gas connections
- check spin rate detector whether light is on
- eject spinner and check marks
- clean spinner

d) Spinner starts but does not speed above ~2 kHz:

- with drive pressure (DP) set to 200 to 300 mbar, reduce bearing pressure (BP) until spinner speeds up, then increase bearing pressure. Listen for clean spinner sound.
- 7 mm: in automation or manual mode: DP=100 mbar, BP=250 mbar: if with these settings spinning is not possible above 400 to 500 Hz, eject spinner and repack. If spinning is faster than 700 Hz, the automation sequence will continue. In manual mode set DP to 250, then increase BP to 1500. Increase DP to 350, set BP to half of the desired spin rate, e.g. BP=2500 for Vd=5000, BP=3000 for Vd=6000, but not higher than 3000. Then set DP to reach desired spin rate.

If spinner slows down during automation after the initial start-up (i.e. DP=100 and BP=250), go to manual mode and decrease DP to 0 and then BP, too. Then eject spinner and check cap for proper positioning. Make sure that the spin rate mark on the bottom of the rotor is correct. A mark which is too weak means that the signal can be lost with fast spinning. Insert spinner and try again in automatic or manual mode. If automatic spin up fails, check again and repeat in manual mode by gently increasing DP as described above.

- 4 mm: in automation mode: reduce start BP to 800, then start again, if it fails, go to manual mode. Set BP to 200, then DP to 200, then increase BP to 1200. Spinning must be faster than 3 kHz, if not, stop and eject spinner for repacking.

Usually all 4 mm spinners spin very easily. So, make sure that the cap is properly positioned (i.e. there is no gap between the rotor and the cap) and that the cap is not damaged. Furthermore, make sure that during packing the rotor is equally filled with sample and no empty portion is in the rotor. In most cases it will be better to pour the sample into a 4 mm rotor without packing, because then the already balanced mass of the rotor is bigger than the sample inside, and the loose sample will certainly pack during the start-up procedure.

The critical speed of the 7 mm system is somewhere below 2 kHz, for the 4 mm system somewhere above 2 kHz. Every spinner (4 or 7 mm), that can spin properly (i.e. well balanced and without wobbling) will spin faster than 3 to 4 kHz. In a case where a rotor will not spin faster than 2 kHz, something is incorrect. Having an unstable and therefore wobbling spinner spinning at 2 kHz for longer time can seriously damage the probe as well as the spinner. Once a spinner reached a spin rate considerably faster than 2 kHz, you can be sure that it will reach the specified spin rate (i.e. 7 kHz for 7 mm and 15 kHz for 4 mm systems). Of course you must be sure that sample warm-up and centrifugal force do not change the sample properties substantially, what could in the worst case lead to tear off the cap. It can always happen that during spinning the cap loosens, what is always reflected in an immediate slow down of the spinning. This might happen when in variable temperature experiments the sample melts or does a phase transition combined with severe changes in physical properties. In experiments at elevated temperature the KEL-F caps (of use to +50°C) soften, but usually won't be removed during spinning but sometimes are removed when being stopped.

- e) Samples which are in general difficult to spin:
- liquids: use additional plugs (KEL-F or Teflon) or air tight inserts to prevent liquid from centrifuging out of spinner.
 - solids which melt on high temperature runs: use Teflon plugs.
 - foils: cut to stripes of equal width, roll stripes with tweezers to appropriate diameter and insert into spinner. Thin foils are easier to spin.
 - fibres: wrap into a tight bundle of appropriate diameter with tweezers.
 - large chunks of sample: grind to a particle size of less than 0.1 mm if possible (at least 0.5 mm). For soft materials use liquid nitrogen cooled mill.
 - conductive samples: use small amounts of sample diluted with inert material, always grind to smallest possible particle size.
 - aerosols, very fine powders: pour into spinner without packing.
 - rubbers: try to cut discs with appropriate diameter and stack them into the spinner.

In general the problem is always to get the spinner balanced enough so that it spins up fast enough to balance itself by centrifugal force. So packing must be done such that the rotor is well balanced and/or that it redistributes the sample on spinning. If this cannot be achieved, make the mass of the sample (the unbalanced mass) small compared to the spinner (the balanced mass) by using plugs (spacers), CRAMPS spinners, or air tight KEL-F inserts.

Never speed up to the desired speed immediately. Leave the spinner at 3 to 4 kHz while tuning the probe, then gradually speed up to higher speed. With difficult samples which can redistribute, change speed slowly, spin to 5 to 6 kHz only after some time of stable spinning.

As mentioned above, the 4 mm system spins much more easily than the 7 mm system; therefore use this system for difficult samples if available.

3. Probe does not tune:

- a) eject spinner, insert empty rotor of same material, check tuning
- b) insert sample spinner and retune.

In general, the probe tuning is far off when:

- a liquid sample is inserted.
- when the rotor is of different material than the previous one (high Q probe, quite different dielectric properties of zirconia, silicon nitride, and alumina).
- when the sample is conductive or wet.

4. CP-sensitivity is too low on Glycine C.

- check if rotor is full
- check probe tuning
- check whether field and O2 are set properly, optimize O2 for best S/N.
- check contact time, proton pulse length
- check acquisition time
- check for arcing of proton or X channel
- check enhancement factor, if less than 3:1, then check pulses for ripple or droop

5. Probe arcs:

- Arcs on proton channel: noise level changes irreproducibly
- Arcs on X channel: signal intensity changes irreproducibly

In general: probe arcs at the specified RF level will occur when the probe is dirty or the sample is very lossy. In either case react as follows:

- if probe was not in use for some time let it arc for 10 to 50 scans, if arcing persists, then:
- check gas supply for humidity, replace with different supply

Troubleshooting

- if the probe is known to be contaminated with sample (because a cap was lost or a spinner explosion), never let the probe arc for a long time, but immediately
- open the probe, clean it with a strong stream of dry gas. Experienced operators may take the coil out and clean stator and coil, check for black traces of arcs, wipe off or scratch off. If coil is badly burned, replace with new coil.

Software: Pulse and AU Programs

8

Preliminary pulse programs:

All pulse programs are contained in the standard high resolution pulse program library.

1. *hpdec*
2. *cp*
3. *cptossa*
4. *cptossb*
5. *cpseltics*
6. *cpnqs*
7. *solids.incl*

AU programs:

1. *angle*
2. *paropt* (taken from UXMNMR AU program library)

Preliminary pulse programs

8.1

hpdec

8.1.1

```
;hpdec
;avance-version
;single pulse excitation with high power proton decoupling
;for use with high power X-amplifier

; !!! recable 1H channel f2 direct to probehead !!!
; !!! do not connect via the proton preamplifier !!!

#include <Avance.incl>

1 ze
2 d1 do:f2
  10u pl1:f1 pl12:f2
  (p1 ph1):f1
  2u cw:f2
  go=2 ph31
  3m do:f2
  wr #0
exit

ph1=0 2 1 3
ph31=0 2 1 3

;p1 : f1 channel - power level for pulse (default)
;          [about 0.0 for B-LAX 300]
;p12: f2 channel - power level for CW decoupling
;          [about -3.0 for B-LAH 100]
;p1 : f1 channel - 90 degree high power pulse
;p15: f1(f2) channel - contact pulse
```

```

;d1 : relaxation delay: 5 sec
;      (for Adamantane and Glycine set-up sufficient)
;NS: 4 * n
;DS: 0

;aq: adjust to maximum 50 msec, td ca 2k.

```

cp**8.1.2**

```

;cp
;avance-version
;high power cross polarisation sequence
;using two proton power levels for CP and decoupling

; !!! recable 1H channel f2 direct to probehead !!!
; !!! do not connect via the proton preamplifier !!!

#include <Avance.incl>

1 ze
2 d1 do:f2
  10u pl1:f1 pl2:f2
  (p3 ph1):f2
3u
  (p15 ph2):f1 (p15 ph3):f2
2u cw:f2
10u pl12:f2
go=2 ph31
3m do:f2
wr #0
exit

ph1=1 3
ph2=0 0 1 1 2 2 3 3

```

```
ph3=0
ph31=0 2 1 3 2 0 3 1

;p11 : f1 channel - power level for pulse (default)
;           [about 0.0 for B-LAX 300]
;p12 : f2 channel - power level for pulse (default)
;           [about 0.0 for B-LAH 100]
;p12: f2 channel - power level for CW decoupling
;           [about -3.0 for B-LAH 100]
;p3 : f2 channel - 90 degree high power pulse
;p15: f1 (f2) channel - contact pulse
;d1 : relaxation delay: 1.25 * T1(H1), but > 50 * aq
;NS: 4 * n
;DS: 0
```

cptossa

8.1.3

```
;cptossa
;avance-version
;program for cpmas with TOtal Sideband Suppression
;using short TOSS sequence (see also cptossb)
;using two proton power levels for CP and decoupling
;Dixon et. al., J. Magn. Reson. 49, 341 (1982)
```

```
; !!! recable 1H channel f2 direct to probehead !!!
; !!! do not connect via the proton preamplifier !!!
```

```
#include <Avance.incl>
#include <Solids.incl>
```

```
„DEL1=(0.1885s/l31)-(p2/2)“
„DEL2=(0.0412s/l31)-p2“
„DEL3=(0.5818s/l31)-p2“
```

„DEL4=(0.9588s/31)-p2“
 „DEL5=(0.2297s/31)-p3-(de/2)“

1 ze
 2 d1 do:f2
 10u pl1:f1 pl2:f2
 (p3 ph1):f2
 3u
 (p15 ph2):f1 (p15 ph3):f2
 2u cw:f2
 DEL1 pl12:f2
 (p2 ph5):f1
 DEL2
 (p2 ph5):f1
 DEL3
 (p2 ph5):f1
 DEL4
 (p2 ph5):f1
 DEL5
 go=2 ph31
 3m do:f2
 wr #0
 exit

ph1=1 3
 ph2=0 0 2 2 1 1 3 3
 ph3=0
 ph5=0 2 0 2 1 3 1 3
 ph31=0 2 2 0 1 3 3 1

;pl1 : f1 channel - power level for pulse (default)
 ; [about 0.0 for B-LAX 300]
 ;pl2 : f2 channel - power level for pulse (default)
 ; [about 0.0 for B-LAH 100]

```
;p12: f2 channel - power level for CW decoupling
;           [about -3.0 for B-LAH 100]
;p2 : f1 channel - 180 degree high power pulse
;           optimise for best side band suppression
;p3 : f2 channel - 90 degree high power pulse
;p15: f1 (f2) channel - contact pulse
;d1 : relaxation delay: 1.25 * T1(H1), but > 50 * aq
;NS: 8 * n
;DS: 0
```

cptossb

8.1.4

```
;cptossb
;avance-version
;program for cpmas with TOtal Sideband Suppression
;using long TOSS sequence (see also cptossa)
;using two proton power levels for CP and decoupling
;Dixon et. al., J. Magn. Reson. 49, 341 (1982)
```

```
; !!! recable 1H channel f2 direct to probehead !!!
; !!! do not connect via the proton preamplifier !!!
```

```
#include <Avance.incl>
#include <Solids.incl>
```

```
„DEL1=(0.1226s/l31)-(p2/2)“
„DEL2=(0.0773s/l31)-p2“
„DEL3=(0.2236s/l31)-p2“
„DEL4=(1.0433s/l31)-p2“
„DEL5=(0.7744s/l31)-p3-(de/2)“
```

```
1 ze
2 d1 do:f2
```

```

10u pl1:f1 pl2:f2
(p3 ph1):f2
3u
(p15 ph2):f1 (p15 ph3):f2
2u cw:f2
DEL1 pl12:f2
(p2 ph5):f1
DEL2
(p2 ph5):f1
DEL3
(p2 ph5):f1
DEL4
(p2 ph5):f1
DEL5
go=2 ph31
3m do:f2
wr #0
exit

```

```

ph1=1 3
ph2=0 0 2 2 1 1 3 3
ph3=0
ph5=0 2 0 2 1 3 1 3
ph31=0 2 2 0 1 3 3 1

```

```

;p1 : f1 channel - power level for pulse (default)
;           [about 0.0 for B-LAX 300]
;p2 : f2 channel - power level for pulse (default)
;           [about 0.0 for B-LAH 100]
;p12: f2 channel - power level for CW decoupling
;           [about -3.0 for B-LAH 100]
;p2 : f1 channel - 180 degree high power pulse
;           optimise for best side band suppression
;p3 : f2 channel - 90 degree high power pulse
;p15: f1(f2) channel - contact pulse

```

```
;d1 : relaxation delay: 1.25 * T1(H1), but > 50 * aq  
;NS: 8 * n  
;DS: 0
```

cpseltics

8.1.5

```
;cpseltics  
;avance-version  
;side band suppression with SELTICS  
;using two proton power levels for CP and decoupling
```

```
; !!! recable 1H channel f2 direct to probehead !!!  
; !!! do not connect via the proton preamplifier !!!
```

```
#include <Avance.incl>  
#include <Solids.incl>
```

```
„DEL1=(1s/l31)/24“  
„DEL2=(1s/l31)/24-1.5u“  
„PUL1=(1s/l31)/12“  
„PUL2=(1s/l31)/24“
```

```
1 ze  
2 d1 do:f2  
  10u pl1:f1 pl2:f2  
  p3:f2 ph1  
3u  
  (p15 ph2):f1 (p15 ph10):f2  
  DEL1 cw:f2  
  DEL2 pl12:f2  
  (PUL1 ph5):f1  
3u  
  (PUL1 ph6):f1
```

```

DEL2
DEL1
DEL1
DEL2
(PUL2 ph5):f1
3u
(PUL2 ph6):f1
go=2 ph31
3m do:f2
wr #0
exit

```

```

ph1=1 3
ph2=0 0 2 2 1 1 3 3
ph5=0 0 0 0 0 0 0 2 2 2 2 2 2 2
  1 1 1 1 1 1 1 1 3 3 3 3 3 3 3
ph6=2 2 2 2 2 2 2 0 0 0 0 0 0 0 0
  3 3 3 3 3 3 3 1 1 1 1 1 1 1 1
ph10=0
ph31=0 2 2 0 1 3 3 1

```

```

;p1 : f1 channel - power level for pulse (default)
;      [about 0.0 for B-LAX 300]
;p2 : f2 channel - power level for pulse (default)
;      [about 0.0 for B-LAH 100]
;p12: f2 channel - power level for CW decoupling
;      [about -3.0 for B-LAH 100]
;p3 : f2 channel - 90 degree high power pulse
;p15: f1(f2) channel - contact pulse
;d1 : relaxation delay: 1.25 * T1(H1), but > 50 * aq
;L31: MAS spin rate
;NS: 8 * n
;DS: 0

```

```
;cpnqs
;avance-version
;high power cross polarisation sequence
;using two proton power levels for CP and decoupling
;X-nuclei with strong dipolar coupling are suppressed due to
; interrupted decoupling. To make spectra more easily phaseable,
; chemical shift evolution is refocussed with a X 180 degree pulse.
```

```
; !!! recable 1H channel f2 direct to probehead !!!
; !!! do not connect via the proton preamplifier !!!
```

```
#include <Avance.incl>
```

```
1 ze
2 d1 do:f2
  10u pl1:f1 pl2:f2
  p3:f2 ph1
3u
(p15 ph2):f1 (p15 ph10):f2
d20
(p2 ph2):f1
d20 pl12:f2
go=2 ph31 cw:f2
3m do:f2
wr #0
exit
```

```
ph1=1 3
ph2=0 0 2 2 1 1 3 3
ph10=0
ph31=0 2 2 0 1 3 3 1
```

```

;p11 : f1 channel - power level for pulse (default)
;          [about 0.0 for B-LAX 300]
;p12 : f2 channel - power level for pulse (default)
;          [about 0.0 for B-LAH 100]
;p12: f2 channel - power level for CW decoupling
;          [about -3.0 for B-LAH 100]
;p2 : f1 channel - 180 degree high power pulse
;p3 : f2 channel - 90 degree high power pulse
;p15: f1(f2) channel - contact pulse
;d1 : relaxation delay: 1.25 * T1(H1), but > 50 * aq
;d20: about 25u for strongly coupled nuclei,
;      up to 200u for weakly coupled nuclei
;NS: 4 * n
;DS: 0

```

solids.incl**8.1.7**

```

;Solids.incl - include file for pulses/delays used in solids exp.
;avance-version
;version 96/01/04

;pulses

define pulse PUL1
define pulse PUL2
define pulse PUL3
define pulse PUL4

;delays

define pulse DEL1
define pulse DEL2
define pulse DEL3
define pulse DEL4
define pulse DEL5
define pulse DEL6
define pulse DEL7

```

define pulse DEL8

AU programs

8.2

angle

8.2.1

```
/*
    angle    (940201)
    performs multiple acquisitions and ft's.
    can be stopped while entering „stop“ during acquisition
*/
/*  Ste  */

char *Gets(),strt[8];
int ns, nss;

GETCURDATA
Proc_err(0,„Terminate AU program with 'stop' during acquisition“);
(void)strcpy(strt,Gets(„Do you want adjustment on spectrum? y/n“,„y“));
i1=100000;
fetchpar(„NS“,&ns);
TIMES(i1)
    storepars(„NS“, (ns+1));
    ZG
    fetchpars(„NS“, &nss);
    if ( nss != ns )
    {
        break;
    }
    if (strt[0] == 'y')
    {
        EFP
    }
END
QUITMSG(„--- angle program finished ---“)
```

paropt

8.2.2

see UXNMR AU program library

Figure 9.1. FID and spectrum KBr at the magic angle

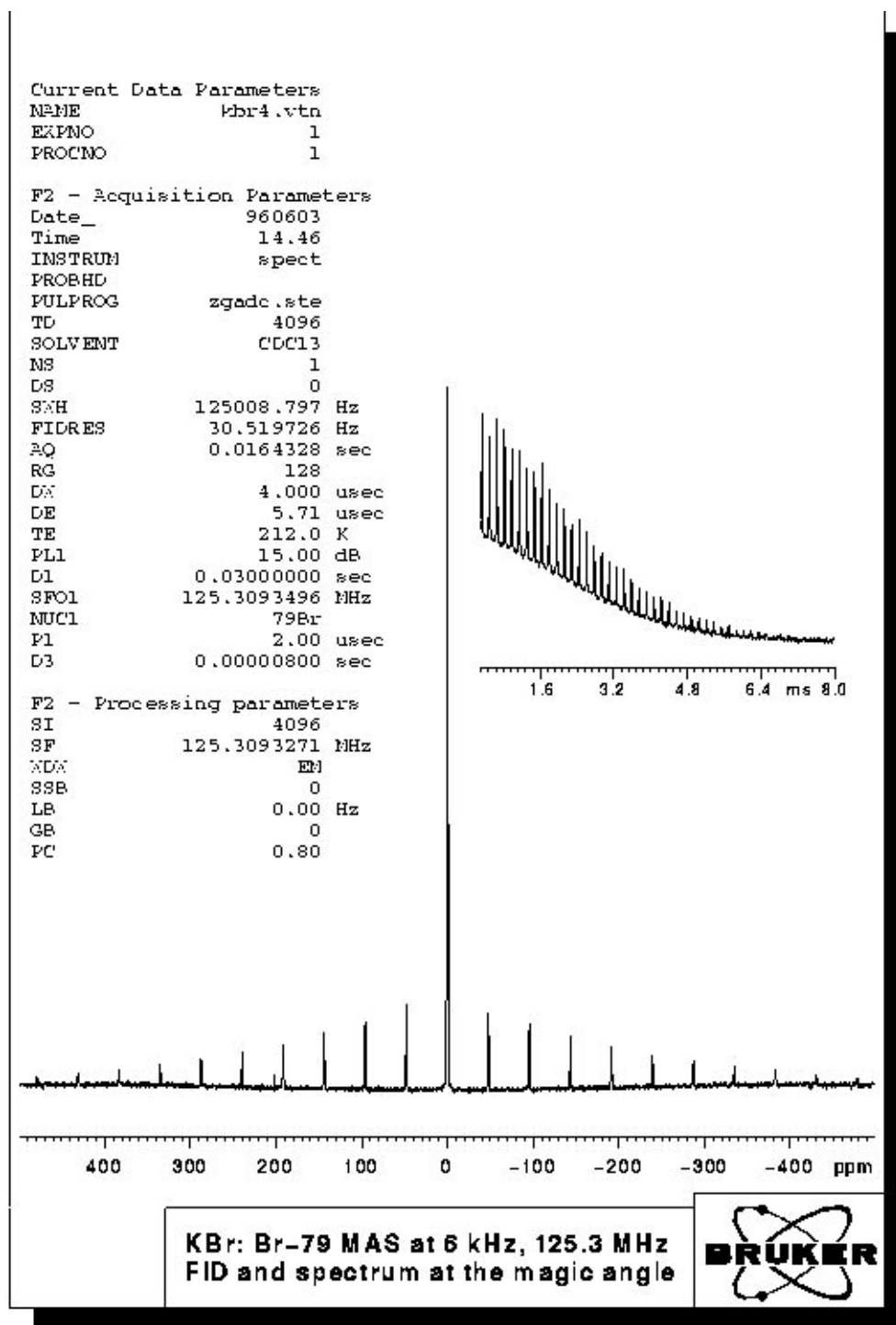

Figure 9.2. FID and spectrum of KBr off magic angle

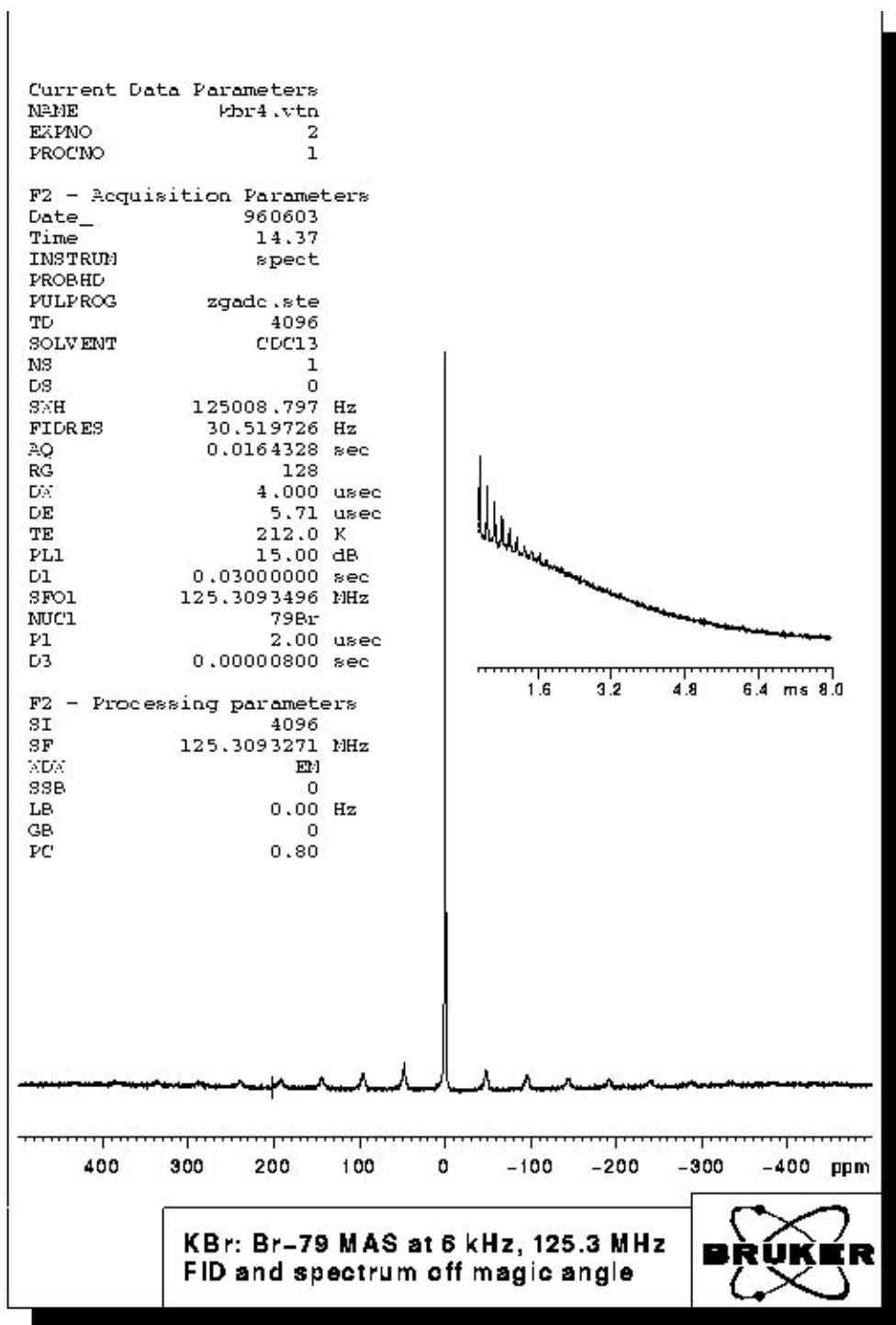

Figure 9.3. Spectrum of Adamantane at 300 MHz

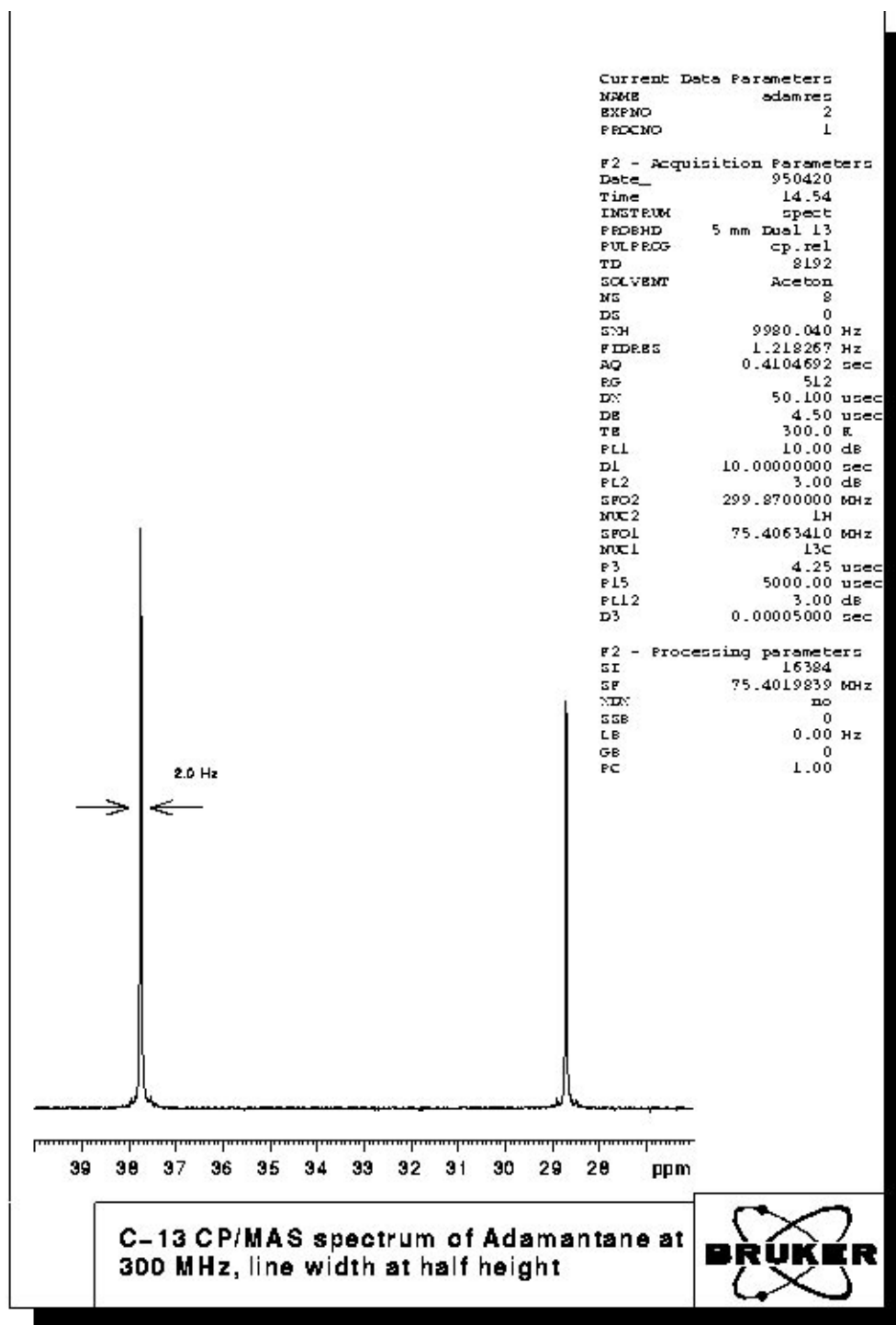
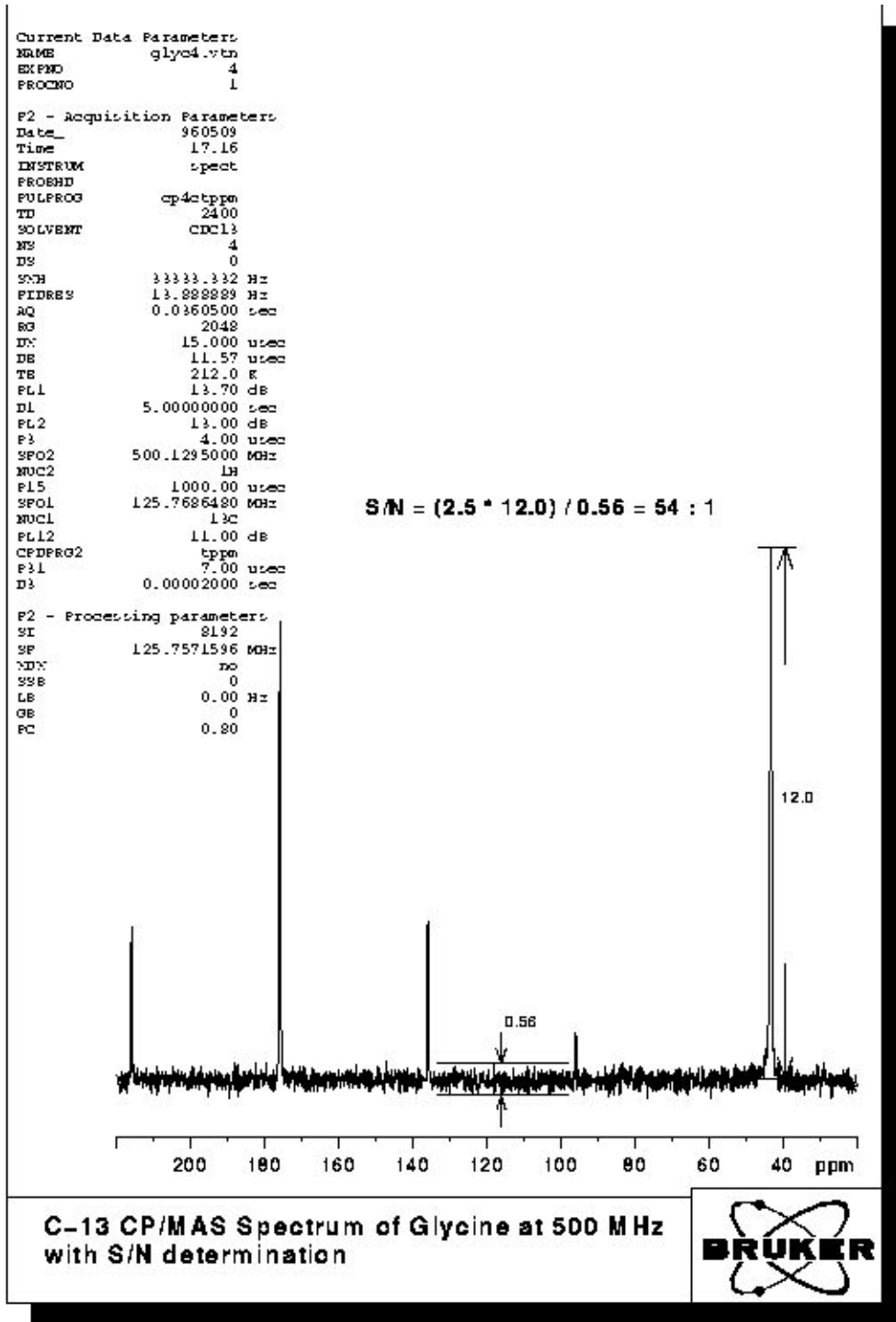

Figure 9.4. Spectrum of Glycine at 300 MHz with S/N determination



Using the Microprocessor Controlled Pneumatic Unit with UXNMR

10

Configuration of the Pneumatic Unit

10.1

The pneumatic unit has a RS232 interface which enables its operation via UXNMR making use of the communication with the host computer. For this the RS232 interface port tty07 of the CCU has to be connected to the RS232 port of the pneumatic unit using the cable PN HZ2481. For this cable the connector labelled „device“ has to be connected to the pneumatic unit, the connector labelled „CCU“ has to be connected to the CCU. When the configuration „cfmas“ is started from UXNMR a dialog box is initiated and you should answer the questions as follows:

Which device is used for MAS unit?	tty07
Minimum main pressure?	4000
Insert air on time	10
Eject air on time	10
Probe diameter (W>=89, N<89)	N
Using MAS in automation	n

⇒ **Probes with a proton frequency higher than 600 MHz have to be treated like WB Probes.**

This information will be stored in the file mas in the directory /u/conf/instr/<spectrometer>/rs232_device. The settings of probe diameter and of eject and insert air on time can be changed in the „mas“ menu described below, but for permanent change of the default settings the „cfmas“ command has to be repeated and the parameters be changed according to the personal wishes.

The pneumatic unit can be fully operated from UXNMR. To enable the communication the MAS unit has to run in remote mode, which can be selected by pressing the corresponding button at the key pad on the front panel. To make sure that the MAS unit goes automatically into this mode when it is switched on, press the „Reset“ button after having selected the „Remote“ mode. Now switch the unit off and then on again. The red LED for the remote mode has to be lit.

Important note: Only switch the MAS unit on when the main pressure is above 4 bar, because this is used for internal calibration of the stepper motor driven valves.

The communication with the MAS unit is initiated using the command „mas“, which will display the window shown below:

Figure 10.1. MAS Pneumatic Unit Control

MAS Pneumatic Unit Control					
MAS Firmware Version:	941205				
Job Setup Filename:	<input type="text"/>				
Bearing Gas Port:	<input type="text"/>				
Probehead Selection:	Diameter	Probe	Type	Material	User
	<input type="text" value="7 mm"/>	<input type="text" value="BL"/>	<input type="text" value="SB"/>	<input type="text" value="ZrO"/>	
		Demand	Actual	Maximum	
Main Pressure:		<input type="text"/>	<input type="text" value="7500"/>	<input type="text" value="10000"/>	mbar
Bearing Pressure:	<input type="text" value="0"/>	<input type="text"/>	<input type="text" value="2500"/>	<input type="text" value="3100"/>	mbar
Drive Pressure:	<input type="text" value="0"/>	<input type="text"/>	<input type="text" value="1020"/>	<input type="text" value="1000"/>	mbar
Spin Rate:	<input type="text" value="5000"/>	<input type="text"/>	<input type="text" value="5010"/>	<input type="text" value="8000"/>	Hz
Setting Mode:	<input type="text" value="Auto"/>				
Spinning:	<input type="text" value="On"/>	Insert AirTime:	<input type="text" value="10"/>	sec	<input type="text" value="Insert Sample"/>
Spin. Locked	<input type="text" value="No"/>	Eject Air Time:	<input type="text" value="10"/>	sec	<input type="text" value="Eject Sample"/>
StartupProgram	<input type="text" value="0"/>				
<input type="button" value="Save"/>	<input type="button"/>	<input type="button" value="ContinuousUpdate"/>	<input type="button" value="Edit"/>	<input type="button" value="List"/>	<input type="button" value="Cancel"/>

The actual status setting of the MAS unit is read and displayed in the line „Probehead Selection:“ You can select the appropriate sample diameter (4 and 7 mm are supported), the probe type (BL for 4 mm rotor diameter and BL or DB for 7 mm). If you are in doubt which probe you have, please refer to the red label at the front panel of your MAS probe. The probe and its diameter are used to define the program that is used when you start up a rotor in the automatic mode. Since the ac-

celeration of various rotors is quite different, optimised programs for the start up procedures of each type of probe have to be used.

For the item „Type“ in the line indicated „Probehead Selection“ you have to define SB for a standard bore probe or WB for a wide bore probe. This selection is important to enable the pneumatic switch between vertical and magic angle position of the stator in the standard bore probes and which is not used for wide bore probes. You have to make sure that the SB type is selected by going to the status display on the MAS unit from panel and selecting type SB. In this mode the up arrow key allows to select a parameter, the down arrow key toggles through the possible settings. Finally, the item „Material“ defines the maximum possible spinning speed by selecting wither ZrO (4 mm: 15 kHz, 7 mm: 7 kHz) or SiN (4 mm: 17 kHz, 7 mm: 7kHz). This parameter will not be displayed in this window but is loaded internally into the MAS unit.

If you have different types of probes, it is probably a good idea to „Save“ the setting in a „Probe Setup File“. Once you clicked the „Save“ button, the already existing setup files will be displayed. You can overwrite an existing file or enter a new file name. Make sure that all users have write permission for the directory /u/exp/stan/nmr/lists/mas. For later use you can select this setup file in the top row of the menu, and the settings contained in this file will be loaded into the MAS unit.

Values for main pressure, bearing pressure, drive pressure, and spin rate are given underneath the probehead selection. The right most column gives the maximum values for all of these parameters. They can be altered interactively but their use is currently not implemented. The values in the column indicated as „Actual“ cannot be altered interactively, but these values are updated when the „mas“ menu is initiated and also when the „ContinuousUpdate“ button is activated. In the „Demand“ column only the value for the spin rate is of interest. Here the value for the desired spin rate is entered. Also values for the bearing pressure and drive pressure can be entered. This will only be active in the manual mode, which needs to be used only for samples which are difficult to spin.

Operation of the Pneumatic Unit

10.3

Sample Insertion and Start of Spinning

10.3.1

⇒ **The following description is only valid for probes with proton frequency up to 600 MHz.**

After having done all hardware connections according to the probe manuals, samples insertion and ejection, spin up and down can be handled by calling up the above described menu with the UXNMR command „mas“.

The first step is to either select an existing probe setup file, or make sure that the correct „Probehead Selection“ is made. Make sure that all hardware connections are made according to the probe manual. With the standard bore probes you then click the „Eject Sample“ button which will switch the stator to the vertical position and after a few seconds switch on the eject air for 10s. A rotor which might be inside the probe will be ejected. When the eject air is switched off again the rotor for the next experiment can be dropped into the MAS transfer system. Clicking the „Insert Sample“ button will switch the stator to the magic angle position after 10s. The rotor must be dropped into the probe before activating this button because otherwise it could happen that the stator is flipped just when the rotor is between

the top opening of the probe and the top part of the stator. In this case the rotor as well as the stator including the coil could be damaged.

You can now enter the desired spinning speed at the position of the „Spin Rate“ „Demand „. After clicking spinning to „on“ you can activate the „Continuous Update“ button and the actual setting of the bearing and drive pressures as well as the actual spinning speed will be displayed updating these values every 10s. After the desired spinning speed is reached and stable within (+/-4 Hz for 4s, the status of the „Spin. Locked“ signal will be set to „Yes“ on this display. Simultaneously the red LED „Spin Lock“ at the MAS unit front panel will be lit. Now the system is ready to tune the probe and run the acquisition. With the „Cancel“ button the „mas“ menu can be exited.

Changing the Speed while Spinning is on

10.3.2

When the spinning speed has to be changed while the rotor is already spinning two ways of doing that are possible. The first way is to call up „mas“ and enter the new desired spinning speed. By activating „Continuous Update“ the change of the pressure settings and the spinning speed can be followed. A second possibility is to enter the new spin rate directly using the command „masr“. When this command is typed the actual spin rate of the rotor at this instant is displayed and can be confirmed with <return> or changed by typing the new value. Notice that the complete figure has to be entered, e.g. 10000. Entering 10e3, 1e4, or 1k will be translated into - 10 or 1. On the front panel of the MAS unit you can see that the new value is displayed and that drive pressure and probably also bearing pressure are readjusted for the new spinning speed.

Stopping the Sample Spinning

10.3.3

To stop sample spinning again two possibilities exist to do so. The first is to call up „mas“ and set „Spinning:“ to „off“. You will notice that the mas menu comes up with this flag set to off already, but in fact you have to click on it to set it off (again). An alternative way is to type the command „mash“ in UXNMR. Both ways will initiate the sample stopping procedure programmed in the MAS unit.

For sample ejection and insertion separate commands are also available which will avoid going into the „mas“ menu: „mase“ for ejection and „masi“ for insertion. There is also a command to start the spinning („masg“). These four commands not only allow the direct interactive communication with the MAS unit, but also can be used in the programs. In combination with the MAS sample changer a fully automated operation may be possible. Please refer to the MAS automation manual.

Figure 11.1. Pneumatic Connection Diagram: Part 1

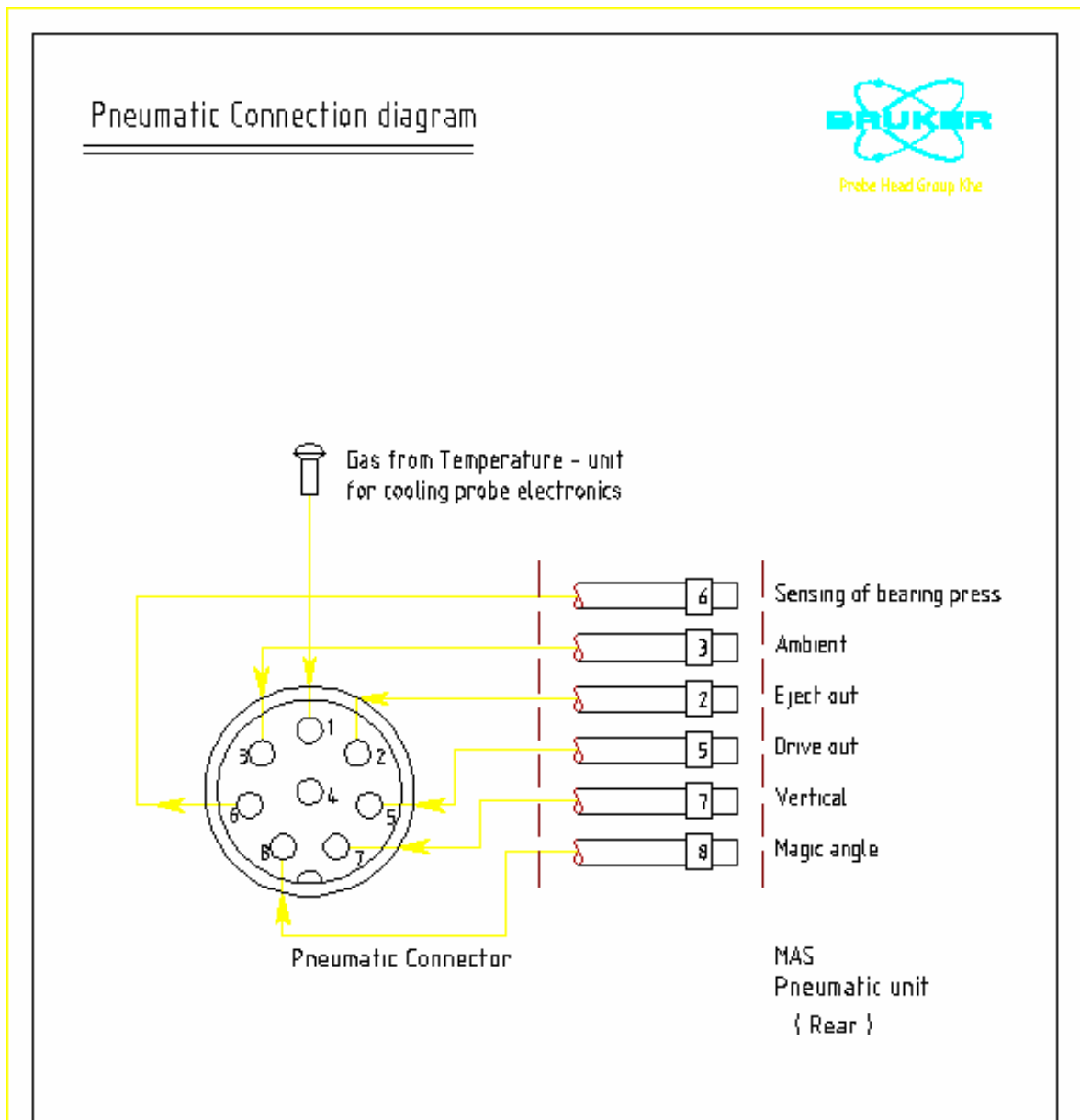

Figure 11.2. Pneumatic Connection Diagram: Part 2

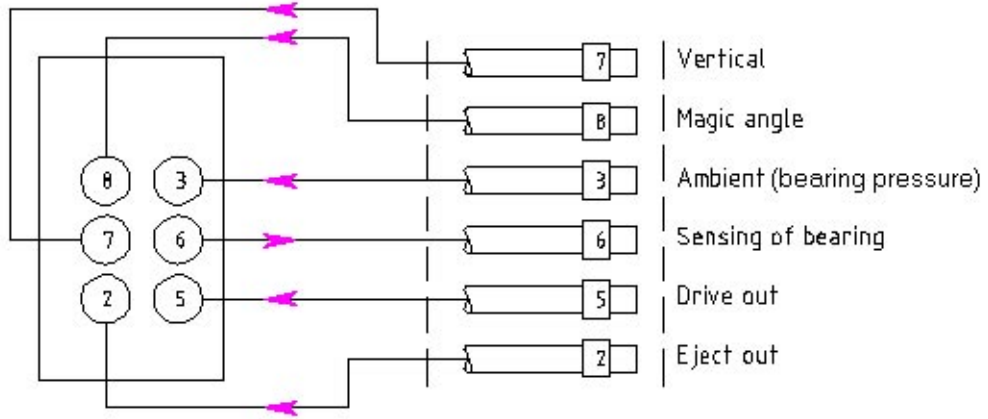

Figure 11.3. Pneumatic Connection for Low Temperature Operation: Part 1

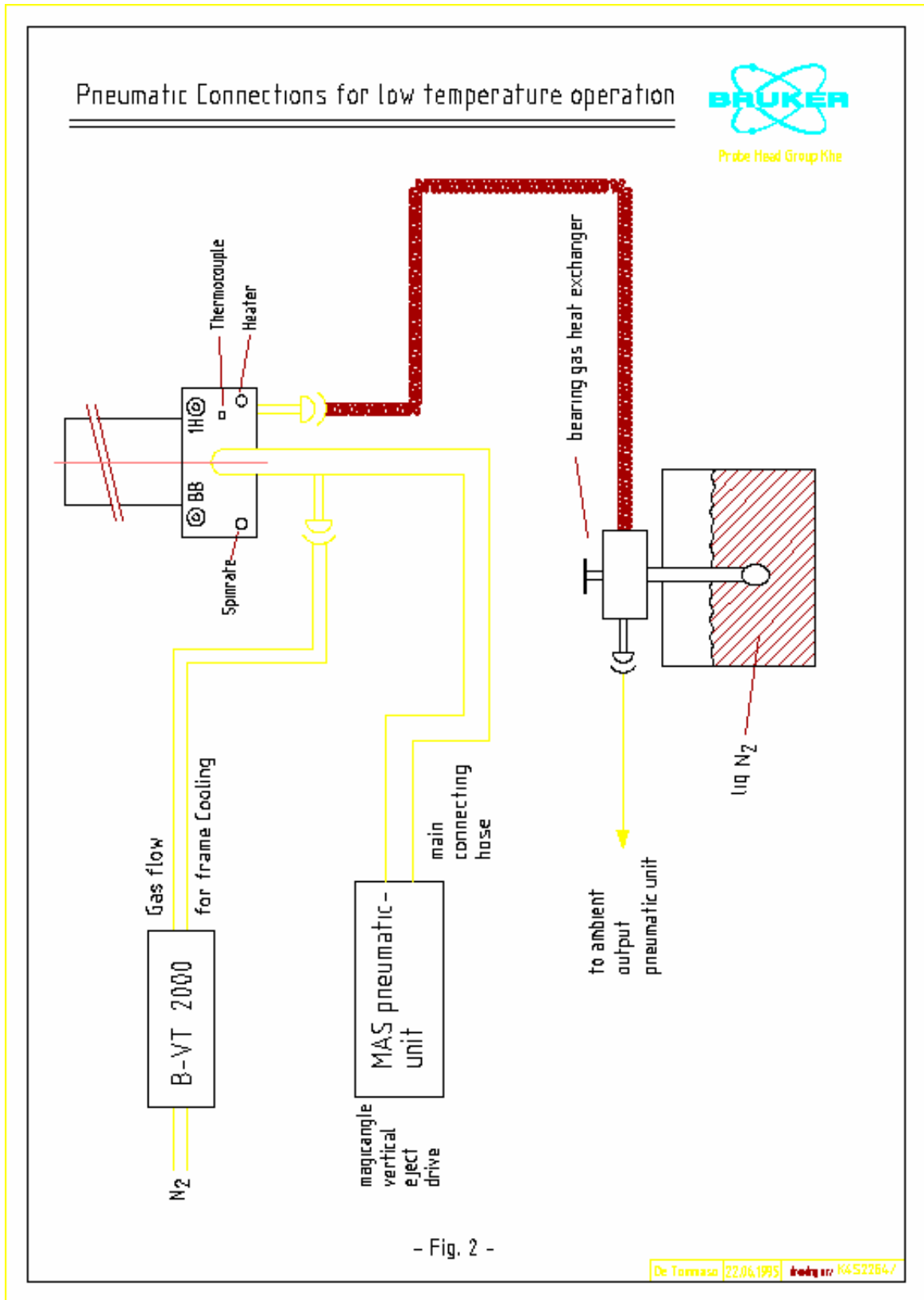

Figure 11.4. Pneumatic Connection for Low Temperature Operation: Part 2

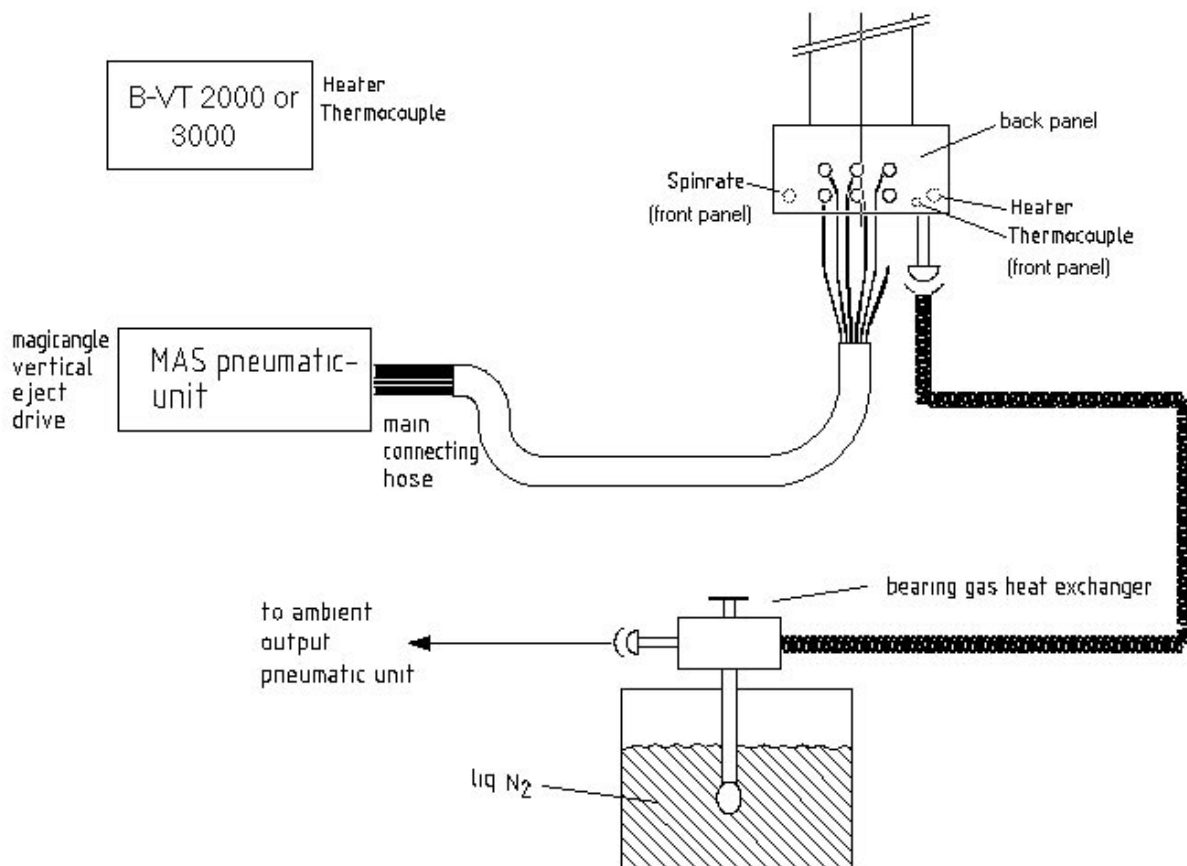

Figure 11.5. RF Connections for CP/MAS Experiments

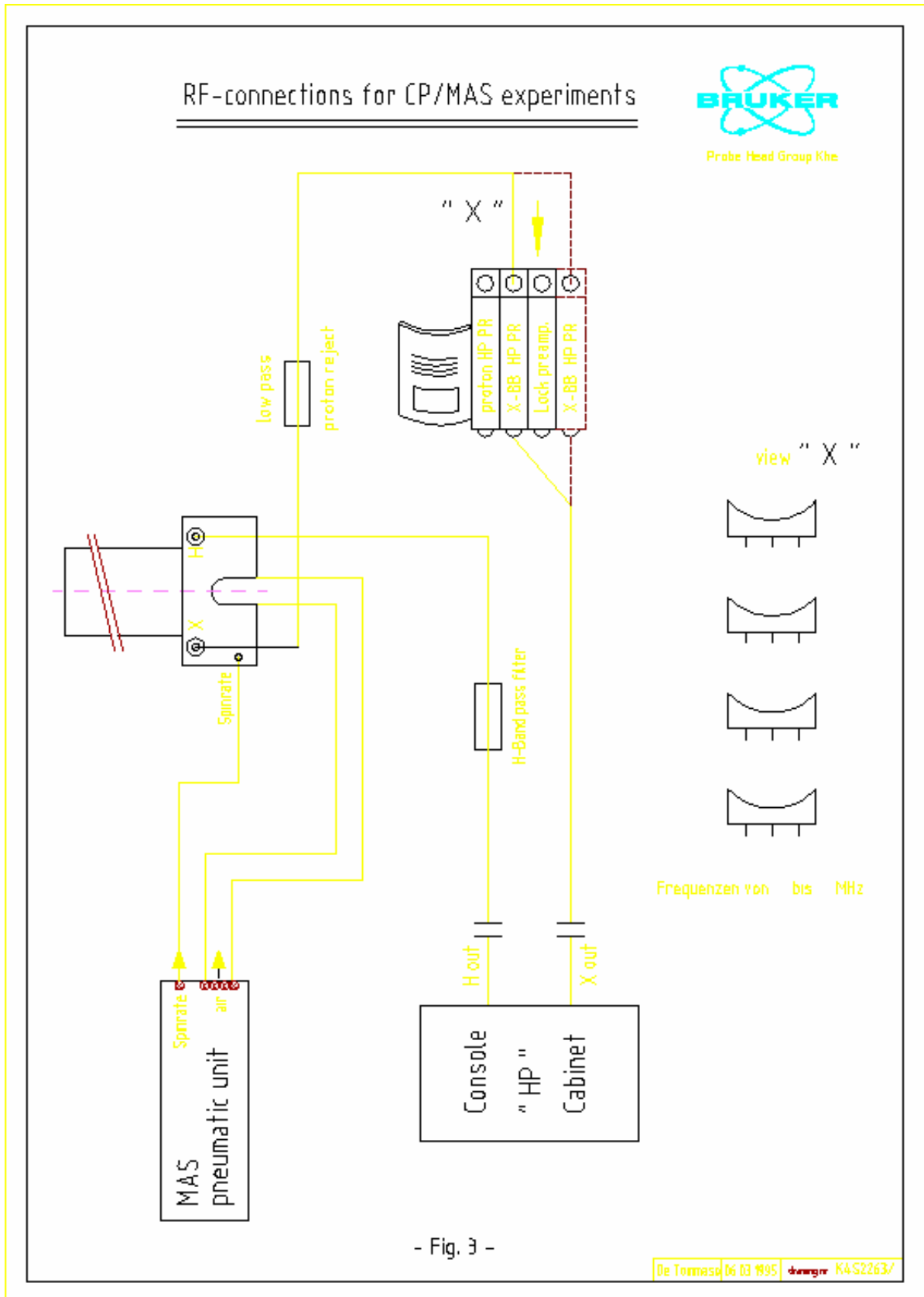

Figure 11.7. RF Diagram

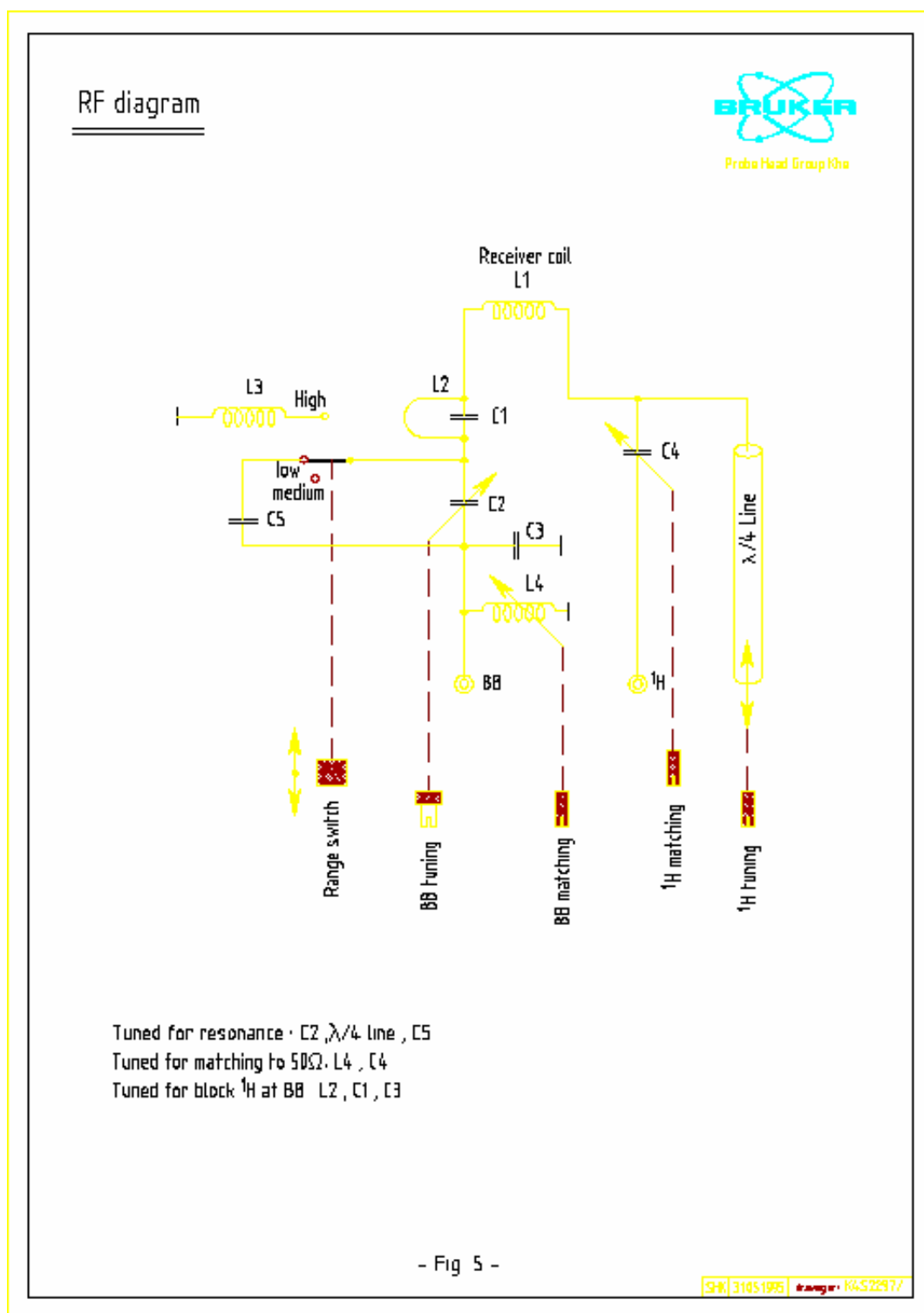
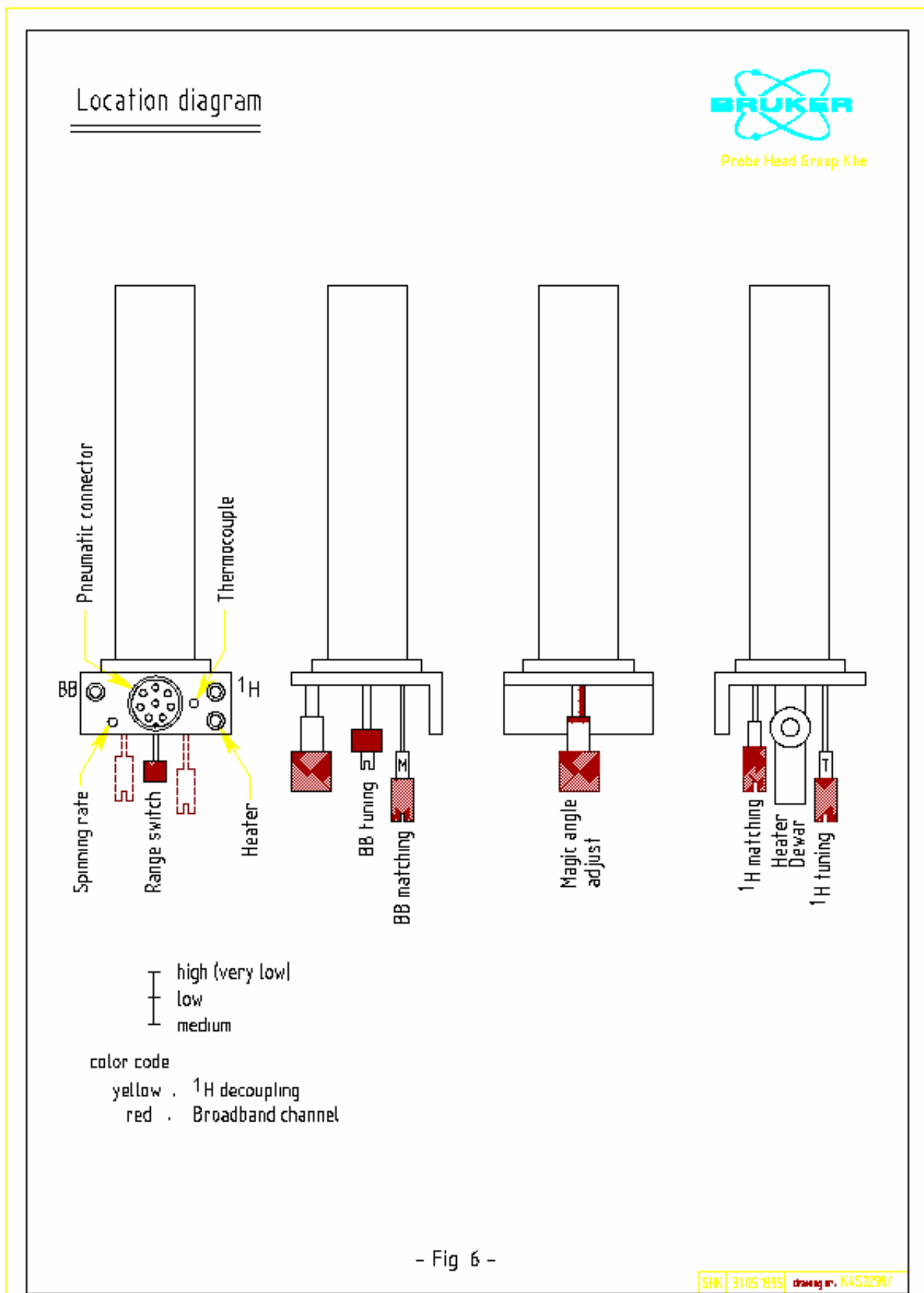

Figure 11.8. Location Diagram



Figures

1 Shipping List	7
2 System Description	9
3 Site Requirements	11
4 Installation	13
5 Introduction to MAS and CP/MAS	15
6 Operation of the SB/MAS Probe	17
7 Troubleshooting	29
8 Software: Pulse and AU Programs	33
9 Spectra	45
Figure 9.1. FID and spectrum KBr at the magic angle	45
Figure 9.2. FID and spectrum of KBr off magic angle	46
Figure 9.3. Spectrum of Adamantane at 300 MHz	47
Figure 9.4. Spectrum of Glycine at 300 MHz with S/N determination	48
10 Using the Microprocessor Controlled Pneumatic Unit with UXNMR49	
Figure 10.1. MAS Pneumatic Unit Control	50
11 Diagrams	53
Figure 11.1. Pneumatic Connection Diagram: Part 1	53
Figure 11.2. Pneumatic Connection Diagram: Part 2	54
Figure 11.3. Pneumatic Connection for Low Temperature Operation: Part 1 55	
Figure 11.4. Pneumatic Connection for Low Temperature Operation: Part 2 56	
Figure 11.5. RF Connections for CP/MAS Experiments	57
Figure 11.6. Function Diagram	58
Figure 11.7. RF Diagram	59
Figure 11.8. Location Diagram	60

Figures

Tables

1	<i>Shipping List</i>	7
2	<i>System Description</i>	9
3	<i>Site Requirements</i>	11
4	<i>Installation</i>	13
5	<i>Introduction to MAS and CP/MAS</i>	15
6	<i>Operation of the SB/MAS Probe</i>	17
Table 6.1.	PH MAS200-400SB BL4	19
Table 6.2.	PH MAS200-400SB BL7	19
7	<i>Troubleshooting</i>	29
8	<i>Software: Pulse and AU Programs</i>	33
9	<i>Spectra</i>	45
10	<i>Using the Microprocessor Controlled Pneumatic Unit with UXNMR 49</i>	
11	<i>Diagrams</i>	53





Bruker Corporation

info@bruker.com
www.bruker.com

Order No: Z31401