



# 400'54 Ascend /R

● User Manual



Copyright © by Bruker Corporation

All rights reserved. No part of this publication may be reproduced, stored in a retrieval system, or transmitted, in any form, or by any means without the prior consent of the publisher. Product names used are trademarks or registered trademarks of their respective holders.

© January 2012: Bruker Corporation

Fällanden, Switzerland

ZTKS0238 / Z31957 / Rev.: 00

For further technical assistance on the NMR magnet system, please do not hesitate to contact your nearest BRUKER dealer or contact us directly at:

BRUKER Corporation  
Industriestrasse 26  
CH - 8117 Fällanden  
Switzerland

Phone: + 41 44 825 91 11  
Fax: + 41 44 825 96 96  
E-mail: [service@bruker.ch](mailto:service@bruker.ch)  
Internet: [www.bruker.com](http://www.bruker.com)

---

<b>0</b>	<b>Contact .....</b>	<b>9</b>
<b>1</b>	<b>Introduction.....</b>	<b>11</b>
<b>2</b>	<b>Safety .....</b>	<b>15</b>
<b>3</b>	<b>Transportation .....</b>	<b>31</b>
<b>4</b>	<b>Assembling .....</b>	<b>37</b>
<b>5</b>	<b>Operation.....</b>	<b>39</b>
<b>6</b>	<b>Troubleshooting .....</b>	<b>41</b>
<b>7</b>	<b>Maintenance.....</b>	<b>65</b>
<b>8</b>	<b>Disassembling .....</b>	<b>69</b>
<b>A</b>	<b>Appendix .....</b>	<b>71</b>



<b>0</b>	<b>Contact .....</b>	<b>9</b>
<b>1</b>	<b>Introduction.....</b>	<b>11</b>
1.1	General Information.....	11
1.2	Limitation of Liability .....	11
1.3	Customer Service.....	11
1.4	Warranty.....	11
1.5	Copyright.....	11
1.6	General View.....	12
<b>2</b>	<b>Safety.....</b>	<b>15</b>
2.1	Approved Persons.....	15
2.2	Customer Responsibilities.....	16
2.3	Key Words.....	17
2.4	Residual Risks.....	18
2.4.1	Persons .....	18
2.4.2	Intended Use .....	18
2.4.3	Safety Devices .....	19
2.4.4	Spare Parts .....	19
2.4.5	Signs and Labels.....	20
2.4.6	Technical Risks .....	20
2.5	Personal Protective Equipment.....	26
2.6	Description of Signs and Labels.....	27
2.7	Safety Devices .....	28
2.8	Behavior in Danger and Emergency Situations.....	30
2.9	Fire Department Notification.....	30
<b>3</b>	<b>Transportation .....</b>	<b>31</b>
3.1	Safety .....	31
3.2	Packaging.....	31
3.2.1	Disposal.....	32
3.3	Transport Inspection.....	32
3.4	Transportation by Fork Lift / Pallet Jack.....	33
3.5	Transportation with a Crane .....	34
3.6	Storing .....	35
<b>4</b>	<b>Assembling .....</b>	<b>37</b>
4.1	Safety .....	37
<b>5</b>	<b>Operation.....</b>	<b>39</b>
5.1	Safety .....	39
5.2	Set into Operation .....	40

<b>6</b>	<b>Troubleshooting .....</b>	<b>41</b>
6.1	Safety .....	41
6.2	Problem .....	42
6.2.1	During Transportation.....	42
6.2.2	During Assembling .....	42
6.2.3	During Cool Down .....	44
6.2.4	During Energizing and Shimming.....	48
6.2.5	During Operation of the Magnet Stand.....	50
6.2.6	During Standard Operation.....	52
6.2.7	During De-energizing and Warming up .....	55
6.2.8	During Operation of the Cryogenic Refrigerator .....	56
6.3	Troubleshooting Work .....	61
6.3.1	After a Quench .....	61
6.3.2	Procedure in case of an alarm signal .....	63
6.3.3	Procedure in case of Cryogenic Refrigerator failure.....	64
<b>7</b>	<b>Maintenance.....</b>	<b>65</b>
7.1	Safety .....	65
7.2	Cleaning .....	66
7.3	Maintenance Timetable .....	66
<b>8</b>	<b>Disassembling .....</b>	<b>69</b>
8.1	Safety .....	69
<b>A</b>	<b>Appendix .....</b>	<b>71</b>
A.1	Warning Signs .....	73
A.2	Figures.....	75
A.3	Tables.....	77
A.4	Glossary / Abbreviations.....	79
A.5	Technical Data MS 400'54 Ascend /R.....	81
A.6	Index.....	109





# 0 Contact

**Manufacturer:**

Bruker BioSpin AG

Industriestrasse 26

CH-8117 Faellanden

Switzerland

Phone: +41-44-825-91-11

Fax: +41-44-825-96-96

<http://www.bruker.com>

E-mail: [service@bruker.ch](mailto:service@bruker.ch)

Please refer to the Model No., Serial No. and Internal Order No. in all correspondence regarding the NMR system or components thereof.



# 1 Introduction

## 1.1 General Information

---

This manual contains important information about the handling of the supplied magnet system used for NMR analyses. The compliance with all safety and handling instructions, the applicable local accident prevention and general safety regulations are necessary for safe work.

The manual is part of the product. It must be kept in the immediate vicinity of the magnet system and unimpeded access must be ensured at any time. Read the manual carefully before handling the magnet system or its components.

## 1.2 Limitation of Liability

---

The information in this manual will take into account the current state of the technology.

The manufacturer assumes no liability for damages resulting from:

- non-compliance with the instructions and all applicable documentation,
- use for purposes not intended,
- not sufficiently approved persons,
- arbitrary changes or modifications and
- use of not approved spare parts or accessories.

## 1.3 Customer Service

---

Technical support is provided by Bruker service via telephone or e-mail. For contact information see page 9 of this document.

## 1.4 Warranty

---

The warranty terms can be found in the sales documents of the magnet system and in the Terms and Conditions of Bruker BioSpin AG.

## 1.5 Copyright

---

No part of this publication may be reproduced, stored in a retrieval system, or transmitted, in any form or by any means without the prior consent of the publisher. Product names used are trademarks or registered trademarks of their respective holders.

## 1.6 General View

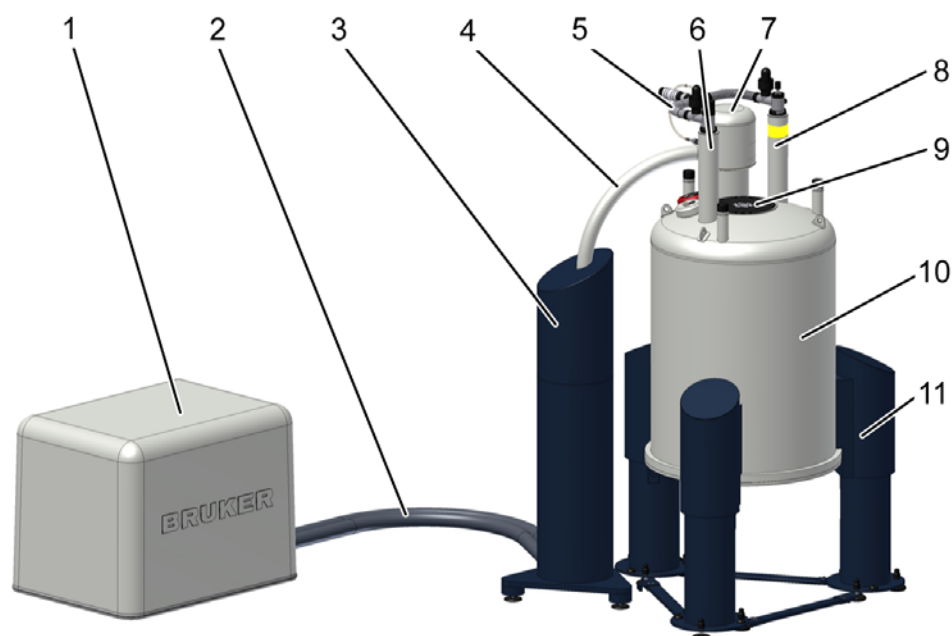

1. Cryogenic Refrigerator Compressor (noise protection cover optionally)
2. Cryogenic Refrigerator Flex Lines
3. Rotary Valve (RV) covered by the Rotary Valve Column (RVC)
4. Connection Line
5. Helium flow system
6. Current lead turret
7. Cryogenic Refrigerator Cold Head
8. Helium fill-in turret with helium fill-in port
9. RT bore
10. RT vessel
11. Magnet Stand

**HELIUM  
FILL-IN PORT**

CAUTION: Use only this port for helium refill!  
Don't leave the helium ports open  
for more than 5 seconds!  
(cf. magnet manual for further information)

Figure 1.1: General view RS Cryostat of the Magnet System

The heart of the NMR magnet system is a superconducting magnet located inside the helium vessel, which is filled with liquid helium. The helium vessel is surrounded by a radiation shield (RS) cooled by a Cryogenic Refrigerator. The outer casing, the room temperature (RT) vessel (10) contains the helium vessel and the radiation shield. The vacuum inside the RT vessel reduces thermal conduction. RT vessel, helium vessel, radiation shield, helium turrets, helium flow systems and the RT bore together build the cryostat of the NMR magnet system. The RT bore (9) allows the access to the magnetic centre of the NMR magnet system.

The cryostat is mounted on a magnet stand (8). The isolators in the magnet stand absorb floor vibrations. Different heights and isolators are available optionally.

The helium turrets (5, 8) build the interface of the helium vessel to the outside. The current lead turret (5) builds the interface for energizing the magnet coil and for diagnostic. The helium fill-in turret (8) with access to the siphon and connecting plug for the helium level sensor is used to fill the helium vessel. It is marked with a yellow label. The helium flow system (6) connects the two helium turrets.

The Cryogenic Refrigerator is a closed loop helium expansion cycle. It consists of a Compressor (1), two Flex Lines (2), a Remote Rotary Valve inside the Rotary Valve Column (RVC; 3), a Cold Head (7) and a Connection Line (4) between Remote Rotary Valve and Cold Head. The Remote Rotary Valve, Flex Lines, Connection Line and Cold Head are covered with an applicable noise protection cover. For the Compressor a noise protection is available optionally.

Depending on the customers site restrictions several opportunities for the additional equipment of the Cryogenic Refrigerator are possible. Refer to the order subscription and to the supplied manuals of the supplied equipment.



## 2 Safety

The supplied cryostat of the magnet system was designed and manufactured according to best available technical knowledge and practice, archived in over 50 years of experience of Bruker Corporation. International standards for quality and approval recommended for cryostats of superconducting magnets were certified.

Nevertheless non-compliance with the following instructions and safety advice may cause serious hazards and property damage.

### 2.1 Approved Persons

---

Bruker BioSpin AG identifies the following qualifications for personnel performing tasks on the magnet system or its components:

#### **Approved Customer Personnel:**

As a result of professional training by Bruker Service Personnel, experience and knowledge of applicable regulations these persons are qualified to perform the specific tasks on the magnet system and its components assigned to them in this manual. Approved Customer Personnel are qualified to identify possible hazards and risks associated with the tasks assigned to them and to perform all possible steps to eliminate or minimize these risks.

#### **Bruker Service Personnel:**

These persons are qualified by appropriate qualification and professional training and experience (including all necessary knowledge of applicable regulations and regulatory requirements) to perform specific tasks on the magnet system and its components. Bruker Service Personnel are qualified to identify possible hazards and risks and to perform all possible steps to eliminate or minimize these risks.

## 2.2 Customer Responsibilities

---

The customer must obey the security advice and the rules for safety, accident prevention and environmental protection correctly for the magnet system. Furthermore, the customer is responsible for keeping the magnet system in good technical condition.

**In particular:**

- The customer must identify additional dangers resulting from the working conditions at the site of the magnet system and provide applicable safety measures.
- The customer must ensure that the site plan meets the specified conditions for operating the magnet system and supplied site planning document.
- The customer must clearly mark the danger area around the magnet system and post the corresponding instruction plates.
- The customer has to ensure the intended use of the magnet system.
- The customer has to inform the local fire brigade about the special risks of the magnet system and how to react in the event of an incident.
- The customer must clearly define the responsibilities for operation and maintenance.
- The customer must ensure that all employees working with the magnet system have read and understood the manual.
- The customer has to provide the necessary personal protective equipment for his employees.
- The customer has to instruct his employees at regular intervals on hazards and safety measures.
- The customer has to instruct other persons not working on the magnet system but carrying out work in the same room, for instance cleaning staff or guards about the possible danger at the site of the magnet system.
- The customer has to consider the specific items of this cryostat equipped with a Cryogenic Refrigerator. The customer is responsible for obeying the advice given in this manual. In case the Cryogenic Refrigerator is not running correctly his immediate reaction is mandatory. In case of an unexpected alarm his immediate response is mandatory. For further instruction refer to chapter "**Troubleshooting**" on page 6-87.
- The customer must ensure that maintenance is performed according to the schedule listed in chapter "**Maintenance Timetable**" on page 7-66.

## 2.3 Key Words

---



### **DANGER**

Indicates a hazardous situation which, if not prevented, will result in death or serious injury.



### **WARNING**

Indicates a hazardous situation which, if not prevented, could result in death or serious injury.



### **CAUTION**

Indicates a hazardous situation which, if not prevented, may result in moderate or minor injury.

### **NOTICE**

Hazard, which could result in property damage.



Information and links for efficient and trouble-free handling and operation.

---

## 2.4 Residual Risks

---

In the following section, the residual risks from the risk analysis according ISO 14971 are summarized. To prevent health hazards and hazardous situations obey all safety instructions and warnings in the manual.

### 2.4.1 Persons

---

#### **WARNING**



##### **Risk of injury and property damage by not approved persons.**

Incorrect handling of the magnet system from not approved persons may result in significant bodily injury and property damage.

Thus:

- Work must only be carried out by approved persons with applicable qualifications. The necessary qualifications are specified in the beginning of the relevant chapter.
- In case of doubt, contact Bruker Service. Contact information see page 9 of this document.

### 2.4.2 Intended Use

---

The supplied magnet systems is designed and intended for NMR spectroscopy only.

#### **WARNING**



##### **Risk of damage to life and limb by incorrect use of the magnet system.**

Incorrect use of the magnet system can lead to life-threatening situations and destruction of the magnet system.

Thus:

- Only use the magnet system as intended.
- Do not change the magnet system.
- Do not exceed specified values for operating the magnet system.
- Do not use inserts inside the RT bore not approved by Bruker Service.

Damage claims from damages caused by other than the intended use of the magnet system are excluded and the customer is held liable.

### 2.4.3 Safety Devices

---

#### WARNING



##### **Risk of damage to life and limb due to not sufficient safety devices.**

Several safety devices ensure safe operation of the magnet system. They must always be in correct working condition.

Thus:

- Do not block safety devices.
- Do not remove safety devices.
- Check the operational reliability of the safety devices before working on the magnet system.

### 2.4.4 Spare Parts

---

#### WARNING



##### **Risk of injury and property damage from using incorrect or defective spare parts and accessories.**

Incorrect or defective spare parts can cause serious injuries. They may cause damaging, malfunctioning and the destruction of the magnet system.

Thus:

- Only use original equipment manufacturer spare parts.
- Only use original equipment manufacturer accessories.

## 2.4.5 Signs and Labels

---



### **WARNING**

#### **Risk of damage to persons and property due to not readable signs and labels.**

Signs and labels with advice may become not readable.

Thus:

- Maintain signs and labels in a readable state.
- Replace damaged or not readable signs and labels immediately. New signs and labels can be obtained from Bruker Service.

## 2.4.6 Technical Risks

---

### Magnetic Field



### **WARNING**

#### **Risk of damage to life and limb due to high magnetic fields.**

A magnetic field of more than 0.5 mT (5 Gauss) is life-threatening for people with pacemakers or metal implants. Exposure to more than 8 T or duration of exposure (8 h/day) above the limit of 200 mT can cause damage to health. Ferromagnetic tools in the magnetic field are significantly hazardous. Disks and electronic devices may be damaged.

Thus:

- Mark the magnetic field of more than 0.5 mT (5 Gauss) before start up.
- The permanent workplace must be outside the 0.5 mT area.
- Do not stay or work at magnetic fields of more than 8 T.
- Prevent exposure of more than 200 mT for more than 8 h/day.
- Keep people with pacemakers and metal implants away from the identified area.
- Keep disks, credit cards and electronic devices away from the identified area.
- Do not use ferromagnetic tools or items within the identified area.
- Only use non-ferromagnetic transportation dewars for the cryogenic agents.
- Only use non-ferromagnetic ladders or steps.

## Cryogenic Agents

### WARNING



#### **Risk of damage to life and limb due to cryogenic agents.**

Risk of damage to life and limb due to not correct handling of liquid cryogenic agents and their dewars. Within the transition from liquid to gas, helium and nitrogen expands their volume, causing closed vessels to burst.

The evaporating cryogenic agents will displace the air. In case of not sufficient ventilation this may result in death by suffocation. Helium displaces oxygen in the upper part of the room, nitrogen displaces oxygen in the lower parts of the room.

Liquid and gaseous cryogenic agents are extremely cold. Contact with liquid or gaseous cryogenic agents will lead to cold burns. Contact with the eyes may cause blindness. Refer to Warning: Low Temperature on [page 2-23](#).

Thus:

- Only use cryogenic agents in well ventilated rooms. In case of doubt ask Bruker Service.
- Wear an oxygen monitor on the body during service and maintenance work.
- Prevent any skin contact with liquid or gaseous cryogenic agents.

## Electricity

### WARNING



#### **Risk of damage to life and limb due to electricity.**

Risk of damage to life and limb due to contact with electrical lines and damaged insulation.

Thus:

- Work on electrical equipment must be done by an approved electrical technician.
- Keep moisture away from electrical lines to prevent short-circuits.
- Check the magnet system accidental ground before start up.
- Switch power OFF before working on the Bruker Power Supply or further equipment.

## Quench



### **WARNING**

#### **Risk of suffocation during a quench of the magnet system.**

A quench is the very fast de-energizing of the magnet by loss of its superconductivity. The stored magnetic energy is converted into heat and thus large quantities of helium evaporate. The evaporating helium will displace oxygen. In case of not sufficient ventilation this may result in death by suffocation.

Thus

- The magnet system site must be well ventilated. In case of doubt contact Bruker Service.
- The evaporating gas may resemble smoke. Never pour water on the magnet system.

## Gas under Pressure



### **WARNING**

#### **Risk of injury due to gas under pressure inside the cryostat and further equipment.**

The helium or the nitrogen vessel of the cryostat may get sealed off due to ice formation inside the helium or the nitrogen turrets in case of non-compliance with the instruction given in this manual. This may lead to overpressure and damage of the helium or the nitrogen vessel.

Manipulations of components with gas under pressure may lead to injury and property damage.

Thus:

- In case of icing inside the helium or the nitrogen turrets contact Bruker Service immediately.
- Release the pressure before working on components with gases under pressure.
- Do not seal cryogenic agent vessels of the magnet system or the transportation dewars.
- Do not connect high pressure transportation dewars for liquid cryogenic agents to the magnet system. Completely eliminate the high pressure from the transportation dewars before connecting and transferring.
- Keep the Cryogenic Refrigerator circuit closed at any time. Overpressure can release in the buffers of the Compressor, the Rotary Valve and the Cold Head.

### Low Temperatures

#### WARNING



##### **Risk of injury due to low temperatures of liquids and metal parts.**

Physical contact with extremely cold liquids and metal parts may cause serious injuries. Contact with the skin may cause cold burns. Contact with the eyes may cause blindness.

Thus:

- Always wear protective goggles, protective gloves and protective clothes while handling with liquid cryogenic agents or metal parts in contact with liquid cryogenic agents.
- Protect temperature sensitive components such as O-rings from contact with liquid cryogenic agents.

### Spontaneous Ignition and Explosion

#### WARNING



##### **Risk of injury from spontaneous ignition and explosion caused by liquid oxygen.**

Pure oxygen condenses on extremely cold metal pieces. Together with oil it may ignite spontaneously. In case of fire the pure oxygen may cause an explosion.

Thus:

- Do not smoke near the magnet system.
- Do not use open flames near the magnet system.
- Keep the environment around the magnet system clean.
- Do not leave oily rags near the magnet system.

### Risk of Slippage

#### WARNING



##### **Risk of injury from slippage.**

The accumulation of condensed water on the floor and ladders causes slippery surfaces.

Thus:

- Always wear safety shoes with an anti slip sole.
- Be careful using ladders.
- Clean floor and ladders regularly.

## Risk of Tilting



### **WARNING**

#### **Risk of injury due to tilting of the magnet system.**

The magnet system is very sensitive to lateral forces. It may tilt.

Thus:

- Do not climb onto the magnet system.
- Do not lean items against the magnet system.
- Do not lean against the magnet system.
- Do not move the magnet system on your own.

## Risk of Heavy Weights



### **WARNING**

#### **Risk of damage to life and limb caused from heavy weights.**

Lifting heavy weights is life-threatening due to falling or moving parts.

Thus:

- Do not stay or work under a lifted magnet system.
- All used lifting equipment must be approved to carry the weight (see Appendix, Technical Data).
- Do not use damaged lifting equipment.
- Do not use lifting equipment without updated check tag.
- Lifting only with approved qualification.
- Obey ergonomic guidelines while lifting heavy parts.
- Protect parts against falling.
- Always wear safety shoes with approved toe caps.

### Risk of Hot Surfaces

#### WARNING



##### **Risk of injury from contact with hot or cold surfaces.**

Surfaces of the Cryogenic Refrigerator parts may be hot. Skin contact with these surfaces can cause serious injuries.

Thus:

- Any work at the Cryogenic Refrigerator parts must only be performed by Bruker Service.
- Always wear protective gloves while handling Cryogenic Refrigerator parts.

### Transportation

#### CAUTION



##### **Risk of injury and property damage due to incorrect transportation.**

The box may tilt, movement may get out of control. Thus persons may get injured and the cryostat or further equipment may be damaged.

Thus:

- Be careful while unloading and moving the boxes.
- Do not move the boxes arbitrarily.
- Pay attention to all symbols on the boxes.
- Pay attention to sharp edges and spikes of boxes and parts by using protective gloves while moving.
- Move the boxes in an upright position.
- Do not tilt the boxes.
- Prevent crossing thresholds, even if they are only a few millimeters high.
- Clean the transportation way before transporting the box.
- Unpack shortly before assembling.
- The cryostat or further equipment must be protected from rain and other bad weather conditions during transportation.
- Exclusively move the cryostat in its original box.
- Do not remove the tightening straps inside the box until assembling.
- Only use the attachment points provided.
- Ensure that the cryostat is always leveled during any transportation.
- Transportation only with transportation locks attached.
- Do not move the evacuated cryostat.
- Do not move the cryostat after cool down.

## 2.5 Personal Protective Equipment

---

The personal protective equipment must be worn at any time while working on the magnet system and to avoid health hazards.



### **Protective Goggles**

Used to protect the eyes from injury due to flying cold liquids and parts.



### **Protective Gloves**

Used to protect the hands from injury caused by contact with extremely cold liquids or surfaces and for protection from injury caused by rough edges.



### **Protective Clothes**

Used to protect the body from injury caused by contact with extremely cold liquids or surfaces and for protection from wounds.



### **Safety Shoes**

Used to protect the feet from injury from falling of heavy objects. An anti-slip sole protects from injury caused by slipping and falling on slippery floor and steps. Only use safety shoes with non-ferromagnetic toe caps.



### **Portable Oxygen Monitor and Alarm**

Used to warn against low oxygen concentrations in surrounding air.

## 2.6 Description of Signs and Labels

---

Signs and labels are always related to their immediately vicinity. The following signs and labels are found on the magnet system and in the vicinity.



**Prohibition sign: No person with pacemakers!**

People with pacemakers are endangered in the identified area of 0.5 mT (5 Gauss) and are not allowed to enter these areas.



**Prohibition sign: No person with implants!**

People with metallic implants are endangered in the identified area of 0.5 mT (5 Gauss) and are not allowed to enter these areas.



**Prohibition sign: No watches or electronic devices!**

Watches and electronic devices may be damaged in the identified area of 0.5 mT (5 Gauss).



**Prohibition sign: No credit cards or other magnetic memory!**

Credit cards and magnetic memory may be damaged in the identified area of 0.5 mT (5 Gauss).



**Prohibition sign: Do not touch! Do not block!**

Do not touch or block identified area.



**Hazard warning sign: Strong magnetic field!**

- No magnetic memory.
- No jewelry.
- No metallic items.



**Emergency exit!**

- Always keep the emergency exit clear.
- Follow the arrows if necessary.
- Doors must be pushed open in escape direction.

## 2.7 Safety Devices

---

The cryostat of the supplied magnet system is equipped with the following safety devices:

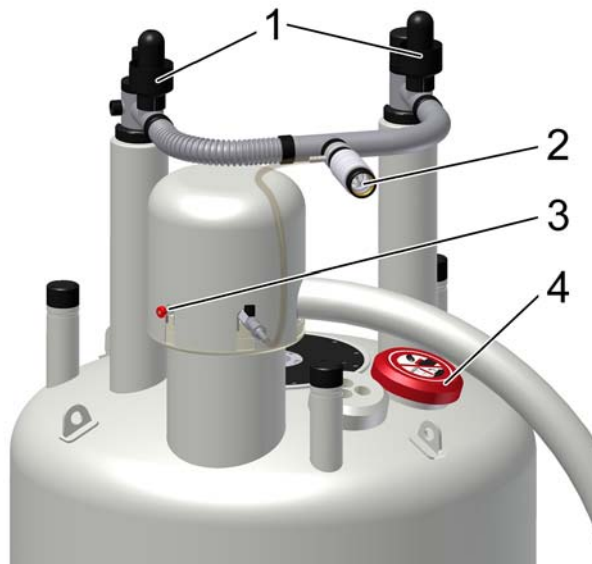

1. Quench Valves
2. One-way Valve of the helium vessel
3. Pressure Relief Valve of the cold head turret
4. Drop-off Plate

Figure 2.1: Safety Devices of the RS Cryostat

## **Quench Valve**

The quench valves (1) are the safety devices of the helium vessel. They open with a defined pressure. In case of an accidental overpressure in the helium vessel the quench valves will release the pressure smoothly.

## **One-way Valves**

The one-way valves at the helium flow system (2) keeps air and moisture from entering the helium vessel in case of an accidental underpressure inside the vessel.

## **Pressure Relief Valve**

The pressure relief valve (3) is the safety device of the cold head turret. It opens with a defined pressure. In case of an accidental overpressure in the cold head turret the pressure relief valve will release the pressure smoothly.

## **Drop-off Plate**

The drop-off plate (4) is a safety device of the RT vessel. If the vacuum breaks, the drop-off plate will open. In case of an accidental overpressure in the RT vessel the drop-off plate will release the pressure smoothly.

## **Cryogenic Refrigerator Parts**

For information about the safety devices of the Cryogenic Refrigerator parts refer to the supplied separate manual.

## 2.8 Behavior in Danger and Emergency Situations

---

### Preparations

- Keep the emergency exits free at all times.
- Prepare and maintain an up-to-date list of emergency telephone numbers in the magnet system area.

### In Case of Emergency

- Leave the danger zone immediately.
- Check for sufficient ventilation in the room before entering, especially if people are showing symptoms of suffocation.
- Rescue persons from the danger zone.
- Provide medical attention for people with symptoms of suffocation.
- Start first aid immediately.
- Call the responsible contact.
- Call for medical assistance.
- Call the fire department.

### First Aid for Cold Burns

- Help the injured persons to lie down comfortably in a warm room.
- Loosen all clothing which could prevent blood circulation in the injured area.
- Pour large quantities of warm water over the affected parts.
- Cover the wound with dry and sterile gauze.
- In case of contact of liquid cryogenic agents with the eyes rinse thoroughly with clean water.
- Call for medical assistance.

## 2.9 Fire Department Notification

---

- Inform the fire department about the potential risks of a magnet system, i.e. danger of ferromagnetic rescue equipment close to the magnet system.
- Laboratory windows which are accessible during an emergency should be clearly identified with warning signs, visible from the outside.
- Inform the fire department about the characteristics of a quench to prevent confusion with smoke.
- Never pour water over the magnet system during a quench!

# 3 Transportation

## 3.1 Safety

The transportation is carried out by Bruker Service or approved persons. However, it may happen that other persons have to receive the delivery of the shipping boxes. In this case it is essential to obey the instructions in this chapter and to inform these persons before.



### WARNING

Heavy Weights (see [page 2-24](#))



### CAUTION

Transportation (see [page 2-25](#))

## 3.2 Packaging



The cryostat is supplied in a wooden box on a pallet. It is secured inside with straps against tilting and moving.

Accessories such as the flow systems, level sensors and bore tubes are in the side compartment of the box.

The Cryogenic Refrigerator parts and the Flex Lines are supplied in boxes on a pallet.

The Magnet Stand is supplied in a wooden box on a pallet.

Figure 3.1: Packaging (without surrounding panels)

## 3.2.1 Disposal

---

Keep the original boxes for future transportation.

If no further transportation is planned, dispose of the boxes according to environmentally friendly regulations.

## 3.3 Transport Inspection

---

Investigate the delivery with regard to visible damage and completeness of delivery.

### Transport control systems

The shipping and handling monitors (“Shock Watch“, “Tilt Watch“) on the boxes shows, if the boxes were kicked or tilted during transportation.

### Checks

Shock Watch: Follow instructions on the label.

Tilt Watch: Follow instructions on the label.

### In case of damage

- Accept delivery with reservation.
- Make a documentation of all observable damage and add it to the transport documents.
- Start complaint process.
- Contact Bruker Service before installation.

---

**i** The claim for damage expires after the fixed period.

Thus:

Report damages to Bruker Service immediately after detection of damage. For contact information see page 9 of this document.

---

## 3.4 Transportation by Fork Lift / Pallet Jack

Recommended for transporting the boxes to the installation site.

**Approved Persons:** Approved forklift / pallet jack operator

**Precondition:** The fork lift / pallet jack must be approved for the transportation weight (see chapter Appendix, Technical Data).

### Transport



1. Check the route of transport for the minimal height and width.
2. Check sufficient floor capacity on the route of transport. In case of doubt ask a stress analyst.
3. Check sufficient carrying capacity while using an elevator.
4. Position the forks between the bars of the box as shown in the figure. Make sure the side towards the operator is the one with the labels on it.
5. Make sure the forks of the fork lift are longer than the box and projects out of the back of the box as shown in the figure below.



6. Now lift the fork and move the box to the site.

Figure 3.2: Transportation by forklift

## 3.5 Transportation with a Crane

Recommended for lifting the cryostat out of the box.

**Approved Persons:** Approved crane operator

**Precondition:** The crane must be approved for the transportation weight (see chapter Appendix, Technical Data).

### Attachment Points

1. Exclusively use the marked eyelets (1) as attachment points for the lifting equipment.
2. Use all eyelets for the lifting equipment.

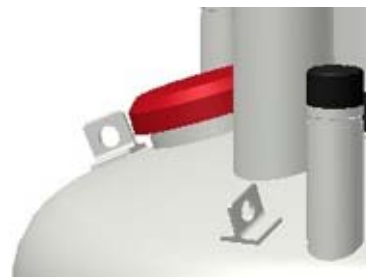
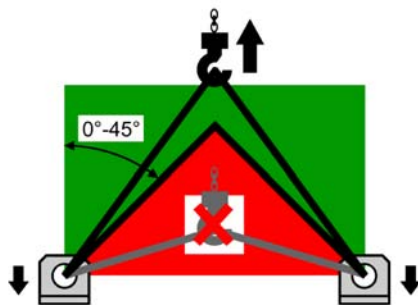

3. Follow the instructions on the label on the top of the cryostat. This label gives important information about correct attachment and transportation.
4. Check for correct fastening of the lifting equipment before lifting the cryostat.
5. Make sure that any movement of the crane is as slowly as possible to avoid any damage due to acceleration.
6. Check for correct leveling of the cryostat while hanging on the crane.

Figure 3.3: Attachment points for lifting equipment

## 3.6 Storing

---

If it is necessary to store the cryostat and accessories before installation obey the following instructions:

- Store the boxes in a closed, dry and dust-free room.
- Store the boxes upright.
- Do not tilt the boxes.
- Do not unpack the supplied boxes.
- Prevent mechanical vibrations to the boxes.
- Storage temperature: 5 - 40 °C.
- Storage humidity: less than 50% @ 23 °C.



# 4 Assembling

## 4.1 Safety

---

Approved Persons: Bruker Service only



# 5 Operation

## 5.1 Safety

---

**Approved Persons:**

Bruker Service, Approved Customer Personnel

 **WARNING**



**Magnetic Fields** (see page 2-20)

**Cryogenic Agents** (see page 2-21)

**Electricity** (see page 2-21)

**Gas under Pressure** (see page 2-22)

## 5.2 Set into Operation

---

Mount the further equipment of the supplied magnet system respecting their manuals.



Figure 5.1: Start the Magnet Stand

Set the magnet stand into operation by switching the pneumatic controller to UP position.



Figure 5.2: Stop the Magnet Stand

For any work at the magnet system like maintenance or refill of helium stop the magnet stand by switching the pneumatic controller to DOWN position.

# 6 Troubleshooting

Troubleshooting must be performed only with approved qualification.

In case of doubts or problems not specified in the following list contact Bruker Service immediately. For contact information see page 9 of this manual.

## 6.1 Safety

---

### Approved Persons

Bruker Service, Approved Customer Personnel

### WARNING



**Magnetic Fields** (see [page 2-20](#))

**Cryogenic Agents** (see [page 2-21](#))

**Electricity** (see [page 2-21](#))

**Gas under Pressure** (see [page 2-22](#))

**Spontaneous Ignition and Explosion** (see [page 2-23](#))

### Personal protective equipment:

- Protective goggles
- Protective gloves
- Protective clothes
- Safety shoes

## 6.2 Problem

---

### 6.2.1 During Transportation

---

Indicator	Possible reason	Solution	By
Tilt Watch / Shock Watch activated.	Careless transportation.	<ol style="list-style-type: none"> <li>1. Accept delivery with reservation.</li> <li>2. Remark the extent of damage in the transportation documents.</li> <li>3. Start complaint process.</li> </ol>	Approved Customer Personnel
Visible damage.	Careless transportation.	<ol style="list-style-type: none"> <li>1. Accept delivery with reservation.</li> <li>2. Remark the extent of damage in the transportation documents.</li> <li>3. Start complaint process.</li> </ol>	Approved Customer Personnel

### 6.2.2 During Assembling

---

Indicator	Possible reason	Solution	By
Ceiling height too low for assembling on magnet stand.	Site does not meet the required conditions.	Choose another site that meets the required conditions.	Bruker Service
Ceiling height too low for inserting the helium level sensor.	Site does not meet the required conditions.	Insert the helium level sensor before mounting the magnet stand.	Bruker Service
Helium bore tube and radiation shield are not concentric.	Alignment is not correct.	Check fixation of the alignment rods.	Bruker Service

Continued on next page

Continued from page before

Indicator	Possible reason	Solution	By
Helium bore tube and radiation shield are not concentric.	Alignment rod is loose or broken.	Replace alignment rod <sup>a</sup> .	Bruker Service
	Reduction flange is not concentric.	Check orientation.	Bruker Service
Vacuum valve collides with the magnet stand.	Vacuum valve collides with the magnet stand.	Turn the vacuum valve. Be careful if the RT vessel is evacuated.	Bruker Service
Vacuum in RT vessel does not reach $5 \times 10^{-5}$ mbar within 48 hours.	O-rings may be damaged.	Check and clean O-rings and slots; replace O-rings if necessary: <ul style="list-style-type: none"> <li>• of the vacuum valve</li> <li>• of the drop-off plate</li> <li>• of the reduction and sealing flanges</li> <li>• of the bottom plate <sup>a</sup></li> </ul>	Bruker Service
	Defective pumping line.	Check pumping line between the cryostat and vacuum pumping unit; change if necessary.	Bruker Service
	Defective pumping unit.	Check pumping unit: A pressure below $10^{-6}$ mbar must be reached with a closed sealing plug.	Bruker Service
	Room temperature bore tube has scratches or dust on the sealing surfaces.	Check sealing surfaces on the room temperature bore tube: No scratches and no dust should be visible.	Bruker Service
	Moisture within the RT vessel.	Pump and flush the RT vessel several times with dry nitrogen gas.	Bruker Service
Super insulation touches RT vessel or bore tube or radiation shield.	Super insulation was not fixed correctly during assembly.	Fix super insulation on the outer radiation shield with polyester tape <sup>a</sup> . Carefully prevent any connection between different vessels or bore tubes in the cryostat.	Bruker Service

<sup>a</sup>. For this work the bottom plate has to be removed. Check the suspension tubes of the helium vessel are not broken. Install the safety device for fall protection (not supplied). Contact Bruker Service Headquarter for further information.

## 6.2.3 During Cool Down

Indicator	Possible reason	Solution	By
Precooling with liquid nitrogen continue too slowly.	Empty transportation dewar.	Refill or change transport dewar.	Bruker Service
	Transfer pressure too low.	Increase transfer pressure slightly.	Bruker Service
	Transportation dewar is leaky; no transfer pressure may be applied.	Check transportation dewar and change if necessary.	Bruker Service
Precooling with liquid nitrogen continue too quickly.	Transfer pressure too high.	Stop precooling. Adjust correct transfer pressure.	Bruker Service
Vacuum in RT vessel does not reach $5 \times 10^{-5}$ mbar.	O-rings may be leaky.	Check and clean O-rings and slots; change O-rings if necessary: <ul style="list-style-type: none"> <li>• of the vacuum valve</li> <li>• of the drop-off plate</li> <li>• of the reduction and sealing flanges</li> <li>• of the bottom plate <sup>a</sup></li> </ul>	Bruker Service
	O-rings may be frozen due to contact with liquid nitrogen.	<ol style="list-style-type: none"> <li>1. Stop precooling.</li> <li>2. Warm up O-ring with warm air</li> <li>3. Wait until the vacuum recovers.</li> <li>4. Prevent liquid nitrogen from splashing on O-rings.</li> </ol>	Bruker Service
	Defective pumping line.	Check pumping line between the cryostat and vacuum pumping unit; change if necessary.	Bruker Service
	Defective pumping unit.	Check pumping unit: A pressure below $5 \times 10^{-5}$ mbar must be reached with a closed sealing plug.	Bruker Service

a. see note on page before

Continued on next page

Continued from page before

Indicator	Possible reason	Solution	By
RT vessel becomes cold and wet.	Vacuum is broken or less than $1 \times 10^{-3}$ mbar.	<ul style="list-style-type: none"> <li>Do not remove pumping unit until liquid helium fill-in is finished.</li> <li>Continue as in problem <i>Vacuum in RT vessel does not reach <math>5 \times 10^{-5}</math> mbar</i> above</li> </ul>	Bruker Service
	Cold leak after transportation.	<ol style="list-style-type: none"> <li>Stop cool down.</li> <li>Warm up cryostat.</li> </ol>	Bruker Service
Cold spot in the RT-bore.	Alignment not correct.	<ol style="list-style-type: none"> <li>Stop cool down.</li> <li>Warm up cryostat.</li> <li>Align the vessels.</li> </ol>	Bruker Service
The helium flow system becomes very cold and icy during pumping and flushing with helium gas.	liquid nitrogen remains in the helium vessel, boiling off strongly during pumping.	<ol style="list-style-type: none"> <li>Stop pumping.</li> <li>Carefully remove all liquid nitrogen through the precooling tube.</li> <li>Check with the dipstick to be sure that the helium vessel is completely empty of liquid nitrogen and of frozen nitrogen (nitrogen ice).</li> </ol>	Bruker Service
After some intervals of pumping and flushing it is not possible to reach a vacuum in the range of 1 mbar.	The globes in the quench valves are not fitting correctly in the O-rings and thus the quench valves are leaky.	<ol style="list-style-type: none"> <li>Stop pumping.</li> <li>Remove frozen air and frozen moisture with warm helium gas.</li> <li>Slightly grease the O-rings and check the position of the globes.</li> <li>Check with the dipstick to be sure that the helium vessel is completely empty of liquid nitrogen and of nitrogen ice.</li> </ol>	Bruker Service
	Liquid nitrogen remains in the helium vessel, boiling off strongly during pumping.	<ol style="list-style-type: none"> <li>Stop pumping.</li> <li>Carefully remove all liquid nitrogen through the precooling tube.</li> <li>Check with the dipstick to be sure that the helium vessel is completely empty of liquid nitrogen and of frozen nitrogen (nitrogen ice).</li> </ol>	Bruker Service

Continued on next page

Continued from page before

Indicator	Possible reason	Solution	By
Nitrogen ice in the helium vessel.	Pumping intervals during pumping and flushing were too long and remaining nitrogen was boiling off and got frozen.	<ol style="list-style-type: none"> <li>1. Warm up the magnet coil with warm helium gas through the precooling tube until the whole coil is warmer than 90 K.</li> <li>2. Repeat pumping and flushing and carefully check with the dipstick to be sure that the helium vessel is completely empty of liquid nitrogen and of frozen nitrogen (nitrogen ice).</li> </ol>	Bruker Service
Transfer of liquid helium does not start.	Empty transportation dewar.	Refill or change transportation dewar.	Bruker Service
	The transfer pressure in the transportation dewar is too low.	Increase the transfer pressure.	Bruker Service
	The transportation dewar is leaky, there is no transfer pressure built up.	Check the transportation dewar for leakage. Tight all connections.	Bruker Service
	The siphon or the helium transfer line are blocked with ice.	Check the siphon and helium transfer line for blockages, remove ice with warm helium gas.	Bruker Service
The cool down of the magnet coil does not continue although helium is transferred.	The helium transfer line is defective.	Check the helium transfer line for icing. If there are cold spots visible, replace the helium transfer line.	Bruker Service
	The extension is not mounted on the helium transfer line.	Mount the extension piece on the helium transfer line. Check the helium transfer line to be inserted completely into the siphon.	Bruker Service

Continued on next page

Continued from page before

Indicator	Possible reason	Solution	By
The zero reading of the helium level sensor can not be adjusted at the beginning of cooling down with liquid helium.	The helium level sensor is not connected correctly with the connector in the helium flow system.	Check the connection in the helium fill-in turret between helium level sensor and connector.	Bruker Service
	The helium level sensor is defective.	Check the helium level sensor with the 0% calibration plug.	Bruker Service
The helium level does not reach 100% after cooling down.	Empty transportation dewar, helium transfer stopped.	Refill or change transportation dewar.	Bruker Service
	The helium level sensor is disturbed by the transfer line's extension piece.	<ol style="list-style-type: none"> <li>1. Stop the liquid helium transfer.</li> <li>2. Remove the transfer line.</li> <li>3. Measure the helium level after some minutes without the transfer line.</li> </ol>	Bruker Service
After cool down the helium boil off is higher than specified (up to 5 times).	Usual behavior. A few days are necessary for the radiation shields and the insulation to reach scheduled temperatures.	Wait a few days and check helium boil off. The presence of the current lead in the current lead turret during energizing and shimming helps to cool down the radiation shield due to higher helium flow.	Bruker Service
Temperature of the radiation shield decreases too slowly (if $T_{RS} > 250$ K after pre-cooling with liquid nitrogen)	Cryogenic Refrigerator not operating.	Start Cryogenic Refrigerator.	Bruker Service
	Cryogenic Refrigeration operating not correct	See "During Operation of the Cryogenic Refrigerator" on page 6-56.	Bruker Service
2 days after cool down the $T_{RS}$ is still higher than set value (alarm of External Temperature Control Unit)	Cryogenic Refrigerator performance not sufficient.	See "During Operation of the Cryogenic Refrigerator" on page 6-56.	Bruker Service
	Alarm default settings of the External Temperature Control Unit or the console not correct.	Check set values (see separate manual of the External Temperature Control Unit and of the console)	Bruker Service
	Cold head not mounted correctly.	See chapter "Mounting the Cryogenic Refrigerator Parts" on page 4-56.	Bruker Service

## 6.2.4 During Energizing and Shimming

Indicator	Possible reason	Solution	By
The current lead can not be inserted completely into the connector.	The connector is covered with ice. (frozen moisture or nitrogen ice).	Carefully remove the ice with warm helium gas. To remove small ice spots use the dipstick or the precooling tube as tubing for the warm helium gas.	Bruker Service
	The shorting plug was not removed.	Remove the shorting plug with the shorting plug tool.	Bruker Service
	The orientation of the current lead is not correct.	Turn the current lead carefully until it can be inserted correctly into the connector.	Bruker Service
Main coil heater test fails.	Defective power supply.	Replace the power supply	Bruker Service
	Connector or cables defective.	Clean connectors or change cables if necessary.	Bruker Service
Setting of sense voltage fails.	The main coil heater switch is "OFF". The main coil switch is not opened.	Switch the main coil heater to "ON" and check the main coil heater current to be adjusted correctly.	Bruker Service
	The main coil heater current is not correct. The main coil switch is not opened.	Adjust main coil heater current correctly.	Bruker Service
	The auxiliary shorting plug is inserted in the current lead turret by mistake and makes a short circuit across the main coil.	Remove the auxiliary shorting plug and insert it in the helium fill-in turret.	Bruker Service
Current lead can not be removed.	The connector is covered with ice (frozen moisture or nitrogen ice).	Carefully remove the ice with warm helium gas over the helium flow system. To remove small ice spots from the connector use the dipstick or the precooling tube as tubing for the warm helium gas.	Bruker Service

Continued on next page

Continued from page before

Indicator	Possible reason	Solution	By
Shorting plug cannot be removed.	The connector is covered with ice (frozen moisture or nitrogen ice).	Carefully remove the ice with warm helium gas. To remove small ice spots use the dipstick or the precooling tube as tubing for the warm helium gas.	Bruker Service
The magnet system quenches	Loss of superconductivity.	See chapter "After a Quench" on page 6-61.	Bruker Service
	The helium level was too low for energizing, cycling, shimming, de-energizing.	See chapter "After a Quench" on page 6-61.	Bruker Service
	The power supply is defective. The main current is oscillating.	Replace the power supply.	Bruker Service
The main coil switch can not be closed on field.	The helium level is too low for energizing. The main coil switch is not covered with liquid helium.	Never try to energize the magnet with less than the "minimum level during energizing" in the helium vessel.	Bruker Service
	The power supply is defective. The main current is oscillating.	Replace the power supply.	Bruker Service
Shim current can not be set correctly.	The control cable is not connected correctly to the current lead or to the power supply.	Connect the control cable correctly to current lead and power supply.	Bruker Service
	Switch „Main Coil/OFF/Shim Coil“ in wrong position.	Change the switch position	Bruker Service
Shims do not affect the NMR signal.	Shim heater current is not correct. The shim switches are not opened.	Set the shim heater current to the specified value (see Appendix Technical Data)	Bruker Service

Continued on next page

Continued from page before

Indicator	Possible reason	Solution	By
Magnet system does not reach specification.	Magnetic material inside RT bore tube.	Carefully clean the RT bore tube.	Bruker Service
	Large ferromagnetic parts are in the vicinity of the magnet system.	<ol style="list-style-type: none"> <li>1. Keep the maximum possible distance between the magnet system and ferromagnetic parts.</li> <li>2. Repeat shimming.</li> </ol>	Bruker Service

## 6.2.5 During Operation of the Magnet Stand

In case of doubt contact Bruker Service and refer to the manual of the Magnet Stand

Indicator	Possible reason	Solution	By
The NMR spectrum shows massive disturbances.	The pneumatic controller is in DOWN position.	Switch pneumatic controller to UP position.	Approved Customer Personnel
	Magnet system has direct mechanical contact with the floor via accessories or cables.	Identify and eliminate contact point. Arrange cables in loose S- or U-shapes.	Approved Customer Personnel
		If the problem is still not solved, contact Bruker Service.	Approved Customer Personnel
	Magnet system has physical contact to the magnet stand.	Check leveling; adjust if necessary.	Bruker Service
	Piston of the isolator is not centric or touches its casing.	Align magnet stand.	Bruker Service
	T-safety brackets touches the pillar.	Align magnet stand.	Bruker Service
	Floor vibrations in horizontal and vertical direction.	Replace air damped isolators with air piston isolators.	Bruker Service

Continued on next page

Continued from page before

Indicator	Possible reason	Solution	By
The isolator of the magnet stand does not reach the operating position.	Pneumatic controller in DOWN position.	Switch pneumatic controller to UP position.	Approved Customer Personnel
	The pressure of the gas supply is too low.	Check the pressure of the gas supply. It must be in the range of 5 to 8 bar (70 to 112 psi).	Approved Customer Personnel
		If the problem is still not solved, contact Bruker Service.	Approved Customer Personnel
	The magnet system is not leveled correctly.	Stop the pneumatic isolators. Check the leveling of the cryostat.	Bruker Service
	Defective leveling valve.	Replace leveling valve or isolator.	Bruker Service
	Defective membrane of an isolator.	Replace leveling valve or isolator.	Bruker Service
Magnet system achieves working position jerkily.	Piston is not centric or touching its casing.	Align magnet stand.	Bruker Service
Audible loss of air	Defective membrane or defective leveling valve of an isolator.	Replace leveling valve or isolator.	Bruker Service
	Hose connector is defective or loose.	Insert hoses correctly and tighten screws.	Bruker Service
Velocity of lifting or lowering too high.	Wrong adjustment of the flow control valve.	Close restrictor of the flow control valve completely; then open it a half turn.	Bruker Service

## 6.2.6 During Standard Operation

Indicator	Possible reason	Solution	By
The helium boil off decrease to zero.	The atmospheric pressure is increasing.	Usual behavior. Watch helium boil off daily.	Approved Customer Personnel
	The helium flow system is covered with ice.	Contact Bruker Service immediately! Do not try to remove ice of the helium flow system!	Approved Customer Personnel
	<b>⚠ WARNING:</b> <b>Cryogenic Agents</b> <b>Quench</b>		
	The helium flow system or the suspension tubes are blocked with ice.	Blow in warm helium gas carefully through an applicable tube. Do not insert it more than 600 mm from the top of the helium turrets.	Bruker Service
The helium boil off is too high.	The helium level meter is permanently on (service mode) or used often.	Switch off helium level sensor. Reduce helium level measurement (during measuring of the helium level an amount of helium boils off due to the heat input of the helium level sensor; for reporting the helium boil off one weekly measurement is sufficient).	Approved Customer Personnel
	The atmospheric pressure is decreasing.	Usual behavior. Watch helium boil off daily.	Approved Customer Personnel
		If the problem is still not solved, contact Bruker Service.	Approved Customer Personnel

Continued on next page

Continued from page before

Indicator	Possible reason	Solution	By
Continue of: The helium boil off is too high.	Vacuum reduced.	Rebuild vacuum, see chapter <b>"Rebuilding the Vacuum" on page 4-55</b>	Bruker Service
	The radiation baffles are not inserted in the current lead turret.	Insert the radiation baffles into the current lead turret.	Bruker Service
RS temperature shield to high.	Cryogenic Refrigeration not sufficient.	See chapter <b>"During Operation of the Cryogenic Refrigerator" on page 6-56.</b>	Approved Customer Personnel
	Alarm default settings not correct.	Check set values (see separate manual of the External Temperature Control Unit).	Approved Customer Personnel
		If the problem is still not solved, contact Bruker Service.	Approved Customer Personnel
	Vacuum reduced.	Rebuild vacuum, see chapter <b>"Rebuilding the Vacuum" on page 4-55.</b>	Bruker Service
Quench	Loss of superconductivity.	See chapter <b>"After a Quench" on page 6-61</b> Contact Bruker Service immediately!	Approved Customer Personnel
Cold spots within the RT bore.	Alignment not correct.	Contact Bruker Service.	Approved Customer Personnel
RT vessel is wet and cold.	Vacuum reduced.	Contact Bruker Service immediately!	Approved Customer Personnel
Not correct helium level warning out of supplied NMR software.	Helium level sensor defective.	Contact Bruker Service immediately!	Approved Customer Personnel
Helium level at constant level, no change during days.	Helium level sensor defective.	Contact Bruker Service immediately!	Approved Customer Personnel

Continued on next page

Continued from page before

Indicator	Possible reason	Solution	By
		<b>⚠ WARNING:</b> <b>Low Temperature</b>	
Not correct helium level warning out of supplied NMR software.	Helium level sensor defective.	Replace helium level sensor (see chapter "Replacement of the Helium Level Sensor" on page 6-111)	Bruker Service
Helium level at constant level, no change during days.	Helium level sensor defective.	Replace helium level sensor (see chapter "Replacement of the Helium Level Sensor" on page 6-111)	Bruker Service

## 6.2.7 During De-energizing and Warming up

Indicator	Possible reason	Solution	By
The magnet system quenches during de-energizing.	The helium level was too low for de-energizing.	Refill helium at least to the minimum allowed level (see Appendix Technical Data).	Bruker Service
	The power supply is defective.	Replace power supply.	Bruker Service
	The main current is oscillating.	Replace power supply.	Bruker Service
The shim current can not be set correctly.	The control cable is not connected correctly to the current lead and/or the power supply.	Connect the control cable to the current lead and to the power supply correctly.	Bruker Service
	The switch "Main Coil/OFF/Shim Coil" is not on the "Shim Coil" position.	Switch "Main Coil/OFF/Shim Coil" on the "Shim Coil" position.	Bruker Service
High helium flow after breaking vacuum.	Remaining cryogenic agents in the inner vessels.	Remove liquid helium.	Bruker Service
Vacuum still remains after 12 hours.	Vacuum valve is closed.	Open vacuum valve. Block it if necessary.	Bruker Service
RT vessel is wet and cold.	Cryostat is still cold.	Wait until RT vessel is dry and warm. Check PT 100 temperature sensors.	Bruker Service
RT bore wet and cold before disassembling.	Cryostat is still cold.	Wait one more day. Do not open a cryostat before the room temperature bore tube is warm and dry!	Bruker Service

## 6.2.8 During Operation of the Cryogenic Refrigerator

---

**i** In the case of a complete failure of the Cryogenic Refrigerator, the helium contained in the helium vessel will be sufficient to cool the magnet for at least 3 days. If solving the issue takes longer, it is necessary to refill helium at all time (refer to supplied Refilling Manual).

---

**i** In case of any issue or failure specified in the following table where the intervention of the operator is necessary, make sure the start button of the compressor is switched off and the power supply of the compressor is disconnected.  
 After resolving the issue, connect the power supply and push the start button of the compressor.  
 If the compressor does not start immediately, press the temperature and the pressure switch for reset and after this the start button on the compressor.  
 For problems not specified in this chapter refer to the supplied manual of the Cryogenic Refrigerator.

---

Indicator	Possible reason	Solution	By
Compressor is not operating.	No power supply or power supply interrupted.	Check the power supply to the compressor and verify that it meets the system requirements.	Approved Customer Personnel
	Circuit breaker OFF.	Check that the circuit breaker on the front panel of the compressor is ON. Check for possible causes why the circuit breaker switched off.	Approved Customer Personnel
		Check for possible causes why the circuit breaker switched off.	Approved Customer Personnel
	Pressure switch tripped	Reset the pressure switch located at the bottom of the front panel of the compressor.	Approved Customer Personnel
	Temperature switch tripped	Reset the temperature switch located at the bottom of the front panel of the compressor.	Approved Customer Personnel

Continued on next page

Continued from page before

Indicator	Possible reason	Solution	By
Compressor is operating, but no pressure fluctuation visible (needles at the pressure gauges not oscillating).	Motor cord disconnected at the compressor.	Connect the motor cord to the compressor.	Approved Customer Personnel
	Motor cord disconnected.	Check the motor cord connection at the coupling in the middle of the motor cord at 10 m (skip, if motor cord is one piece).	Approved Customer Personnel
		<b>⚠ WARNING:</b> <b>Hot Surfaces</b>	
	Motor cord disconnected at the rotary valve.	<ol style="list-style-type: none"> <li>1. Dismount the noise protection cover of the rotary valve column.</li> <li>2. Check the motor cord connection at the rotary valve.</li> <li>3. Connect motor cord, if necessary.</li> <li>4. Remount the noise protection cover.</li> </ol>	Approved Customer Personnel
		If the problem is still not solved, contact Bruker Service.	Approved Customer Personnel
	Aeroquip® connectors of the flex lines not correctly tightened at the compressor.	Tighten the Aeroquip® connectors correctly.	Bruker Service
	High and low pressure helium flex line reversed at the compressor.	Check if the flex lines are mounted correctly at the compressor respecting high and low pressure port.	Bruker Service
Motor cord defective.	Check continuity of all four conductors in the motor cord. If not correct, change the motor cord.	Bruker Service	

Continued on next page

# Troubleshooting

Continued from page before

Indicator	Possible reason	Solution	By
Continue of: Compressor is operating, but no pressure fluctuation visible (needles at the pressure gauges not oscillating).	Aeroquip® connectors of the flex lines tightened not correctly at the rotary valve.	Tighten the Aeroquip® connectors correctly.	Bruker Service
	High and low pressure helium flex line reversed at the rotary valve.	Check if the flex lines are mounted correctly at the rotary valve respecting high and low pressure port.	Bruker Service
	Rotary valve is defective.	If possible, check if the rotary valve sound has changed since installation. If the typical sound is missing, the rotary valve might be defective and has to be exchanged. Replace the rotary valve.	Bruker Service
Compressor is operating, pressure fluctuation visible at the pressure gauges, extinguish short after start.	Water chiller not running.	Check possible reasons why the water cooler is not running. Start the water cooler.	Approved Customer Personnel
	Cooling water flow too low.	Check cooling water supply is sufficient (refer to supplied manual of the Cryogenic Refrigerator).	Approved Customer Personnel
	Cooling water flow too low due to icing, blockage, fouling or leak in the cooling water lines.	Search possible reason for the disturbance. Check the cooling water supply is as specified in the supplied manual of the Cryogenic Refrigerator and the manual of the water chiller.	Approved Customer Personnel
	Not correct environmental temperature (too high or too low).	Check the environmental temperature is as specified.	Approved Customer Personnel
Not correct water temperature (too high or too low).	Check the cooling water temperature is as specified.	Approved Customer Personnel	

Continued on next page

Continued from page before

Indicator	Possible reason	Solution	By	
Compressor is operating, cryogenic refrigeration not sufficient.		Exclude all previous reasons of this list.	Approved Customer Personnel	
	Not correct maintenance.	Check periodic maintenance work was made according to schedule (see chapter "Maintenance Timetable" on page 7-66).	Approved Customer Personnel	
		If the problem is still not solved, contact Bruker Service.	Approved Customer Personnel	
	<b>⚠ WARNING:</b> <b>Hot Surfaces</b>			
	Connection line between rotary valve and cold head not mounted correctly at the cold head.	Tighten the Aeroquip® connectors correctly. Check if the O-rings of the fitting are in correct position (see chapter "Mounting the Rotary Valve and Flex Lines" on page 4-63).	Bruker Service	
	Low helium pressure inside the compressor helium circuit.	Recharge helium of high purity (He 5.0, 99.999%). Refer to supplied manual of the Cryogenic Refrigerator.	Bruker Service	
	Low helium pressure due to small leak inside the helium circuit.	<ol style="list-style-type: none"> <li>1. Leak detection with leak detector at connectors, flex lines, inside compressor, cold head, rotary valve, connection line.</li> <li>2. Eliminate leak, if possible.</li> <li>3. Recharge helium of high purity (He 5.0, 99.999%). Refer to supplied manual of the Cryogenic Refrigerator.</li> </ol>	Bruker Service	
High helium pressure inside the compressor helium circuit.	Vent helium to the set value. Refer to supplied manual of the Cryogenic Refrigerator.	Bruker Service		

Continued on next page

Continued from page before

Indicator	Possible reason	Solution	By
Continue of: Compressor is operating, cryogenic refrigeration not sufficient.	Cold head contaminated.	Remount the cold head. Pump and flush the cold head. See chapter " <b>Procedure in case of Cryogenic Refrigerator failure</b> " on page 6-64	Bruker Service
	Cold head defective.	Replace the cold head. See chapter " <b>Procedure in case of Cryogenic Refrigerator failure</b> " on page 6-64	Bruker Service
	Cryogenic Refrigerator contaminated.	Replace the complete Cryogenic Refrigerator. See chapter and " <b>Mounting the Cryogenic Refrigerator Parts</b> " on page 4-56.	Bruker Service

## 6.3 Troubleshooting Work

### 6.3.1 After a Quench



Figure 6.1: Quench picture

A quench is the very fast de-energizing of the magnet by loss of its superconductivity. The stored magnetic energy is converted into heat, which promotes rapid evaporation of large quantities of helium. After an appearance of a quench contact Bruker Service immediately.



#### **WARNING**

**Cryogenic Agents** (see [page 2-21](#))

**Quench** (see [page 2-22](#))

#### **Quench while in persistent mode:**

1. Wait until the quench valves are closed and no helium evaporate out of the quench valves.
2. Wait until there is no helium vapor visible in the room or the ceiling to make sure there is sufficient oxygen in the room.
3. Switch off the alarm at the External Temperature Control Unit.
4. Check the globes in the quench valves for their correct position.
5. Remove probe and shim system to prevent icing from the shim system.
6. Check the nitrogen turrets for icing.
7. Start the refill with liquid helium as soon as possible after the quench (within one hour after the quench; refer to the supplied refilling manual).
8. Contact Bruker Service immediately.

- 
- i** If the quench occurs unattended or helium transfer was not possible within one hour after the quench, it is recommended to warm up the system to 90 K.
- 

**Procedure to warm up to 90 K:**

1. Switch off the Cryogenic Refrigerator and the water chiller unit, if equipped with.
2. Insert the precooling tube into the helium fill-in turret and connect it to the helium gas dewar.
3. Connect the stop valve at the cold head turret to the helium gas dewar.
4. Blow warm helium gas into the helium vessel.
5. At 90 K pump and flush the helium vessel and the cold head turret with helium gas several times.
6. Re-start the Cryogenic Refrigerator and the water chiller unit, if equipped with.
7. Continue following the instruction according the cooling down procedure (see chapter "**Cooling down to 4.2 K**" on page 4-79).

## 6.3.2 Procedure in case of an alarm signal

---

If the temperature of the radiation shield exceeds the set maximum allowed temperature, an alarm will warn the operator (audible from the External Temperature Control Unit, visible from the External Temperature Control Unit and the console via MICS).

Follow this procedure to fix the issue before contacting Bruker Service.

Note:

- Date and time.
- Temperature given on the display of the External Temperature Control Unit.
- Turn the alarm off (see supplied manual of the External Temperature Control Unit).
- Which errors or warnings appear?
- What are the readings of the pressure gauges, run time counter etc. of the compressor?
- Which parts seems to be ok/not ok?
- How did the failure occur and what happened before failure?

## 6.3.3 Procedure in case of Cryogenic Refrigerator failure

In case of a failure of the Cryogenic Refrigerator the temperature of the shield  $T_{RS}$  will slowly rise to 200 K and the helium boil off to 250 ml/h. This is usual behavior.

In case of failure shorter than 3 days just restart the compressor of the Cryogenic Refrigerator. See remarks at chapter "During Operation of the Cryogenic Refrigerator" on page 6-56 for further information.

After restarting the Cryogenic Refrigerator, at least two days are necessary to recover the previous state of the magnet system. If the temperature and helium boil off does not decrease in the next two days call Bruker Service.

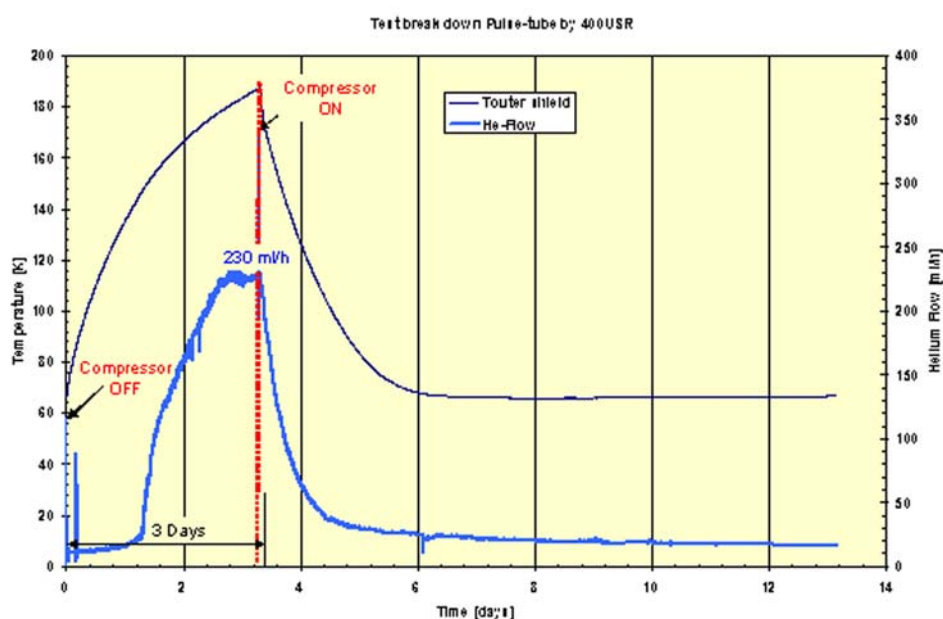

Figure 6.2: Temperature profile during Cryogenic Refrigerator failure

# 7 Maintenance

Maintenance must be performed only with approved qualification.

In case of doubt contact Bruker Service. For contact information see page 9 of this document.

## 7.1 Safety

---

### WARNING



**Magnetic Fields** (see [page 2-20](#))

**Cryogenic Agents** (see [page 2-21](#))

**Electricity** (see [page 2-21](#))

**Gas under Pressure** (see [page 2-21](#))

**Low Temperatures** (see [page 2-23](#))

**Spontaneous Ignition and Explosion** (see [page 2-23](#))

**Hot Surfaces** (see [page 2-25](#))

#### **Approved Persons:**

Bruker Service, Approved Customer Personnel

#### **Personal protective equipment**

Protective goggles

Protective gloves

Safety shoes

## 7.2 Cleaning

### Procedure

- Clean the RT vessel of the magnet system, the magnet stand with dry or slightly damp cloth.
- Only use neutral water and detergents.
- Do not use volatile cleaning solvents.

## 7.3 Maintenance Timetable

Interval	Device	Work	By
daily	Cryostat	Check the helium flow.	Approved Customer Personnel
4.500 h (0.5 year)	Cryogenic Refrigerator	<ul style="list-style-type: none"> <li>• Check the values at the high and low pressure gauges on the front panel of the compressor if the mean values are different and if an oscillation of the needles is noticeable. Refer to the supplied manual of the cryogenic refrigerator. Contact Bruker Service if values are different.</li> </ul> <p>Water cooled option only:</p> <ul style="list-style-type: none"> <li>• Check the proper operation of the water cooling unit.</li> <li>• Check system pressure, water flow and temperatures. Refer to the manual of the water cooling unit for further information.</li> </ul>	Approved Customer Personnel
9000 h (1 year)	Cryostat	<ul style="list-style-type: none"> <li>• Refill helium. Refer to supplied Refilling Manual respecting the warnings and instructions given there.</li> <li>• Record the filling session.</li> </ul>	Approved Customer Personnel

Table 7.1: Maintenance Timetable - part 1

Continued on next page

Continued from page before

Interval	Device	Work	By
17.500 hours (2 years)	Cryogenic Refrigerator	<ul style="list-style-type: none"> <li>• Replace the rotary valve. Refer to chapter <b>"Replacement of the Rotary Valve and the Cold Head"</b> on page 7-120.</li> <li>• Replace the adsorber of the compressor. Refer to the supplied manual of the cryogenic refrigerator.</li> <li>• Check the values at the high and low pressure gauges on the front panel of the compressor if the mean values are different and if an oscillation of the needles is noticeable. Refer to the supplied manual of the cryogenic refrigerator.               <ul style="list-style-type: none"> <li>- Pressure to high: Vent helium gas. Use the Service Kit.</li> <li>- Pressure to low: Refill helium gas of high purity (He 5.0, 99.999%). Use the Service Kit.</li> </ul> </li> </ul>	Bruker Service
35.000 hours (4 years)	Cryogenic Refrigerator	<ul style="list-style-type: none"> <li>• Replace rotary valve and cold head. Refer to chapter <b>"Replacement of the Rotary Valve and the Cold Head"</b> on page 7-120.</li> <li>• Replace the compressor.</li> <li>• Pump and flush the flex lines with helium gas of high purity (He 5.0, 99.999%)</li> </ul>	Bruker Service

Table 7.2: Maintenance Timetable - part 2



# 8 Disassembling

## 8.1 Safety

---

Approved Persons: Bruker Service only





# A Appendix

**Warning Signs**

**Figures**

**Tables**

**Glossary / Abbreviations**

**Technical Data**

**Index**



## A.1 Warning Signs

---

### Danger

Key Word and Symbol .....	17
---------------------------	----

### Warning

Cryogenic Agents .....	21
Electricity .....	21
Gas under Pressure .....	22
Heavy Weights .....	24
Intended Use .....	18
Key Word and Symbol .....	17
Low Temperatures .....	23
Magnetic Field .....	20
Persons .....	18
Quench .....	22
Safety Devices .....	19
Signs and Labels .....	20
Slippage .....	23
Spare Parts .....	19
Spontaneous Ignition and Explosion .....	23

### Warnung/Warning

Art und Quelle der Gefahr .....	25
---------------------------------	----

### Caution

Incorrect Transportation .....	25
Key Word and Symbol .....	17

### Notice

Key Word and Symbol .....	17
---------------------------	----



## A.2 Figures

---

Figure 1.1:	General view RS Cryostat of the Magnet System.....	12
Figure 2.1:	Safety Devices of the RS Cryostat.....	28
Figure 3.1:	Packaging (without surrounding panels).....	31
Figure 3.2:	Transportation by forklift .....	33
Figure 3.3:	Attachment points for lifting equipment.....	34
Figure 5.1:	Start the Magnet Stand .....	40
Figure 5.2:	Stop the Magnet Stand .....	40
Figure 6.1:	Quench picture.....	61
Figure 6.2:	Temperature profile during Cryogenic Refrigerator failure.....	64
Figure A.1:	Dimension Cryostat - Front View .....	84
Figure A.2:	Dimension Cryostat - Top View .....	86
Figure A.3:	Helium Level Graph .....	88
Figure A.4:	Helium Level Sensor .....	89
Figure A.5:	Characteristic Curve PT 100.....	90
Figure A.6:	Characteristic Curve IBT .....	91
Figure A.7:	Wiring Diagramm Temperature Sensors .....	92
Figure A.8:	Current Lead 55 pins .....	94
Figure A.9:	Wiring Diagram Magnet .....	95
Figure A.10:	Wiring Diagram Magnet - Control .....	96
Figure A.11:	Wiring Diagram Magnet - Diagnostic and Temperature Sensors .....	97
Figure A.12:	Shorting Plug 55 pins.....	105
Figure A.13:	Fringe field plot .....	106



### A.3 Tables

---

Table 7.1:	Maintenance Timetable - part 1 .....	66
Table 7.2:	Maintenance Timetable - part 2 .....	67
Table A.1:	Weight Cryostat.....	81
Table A.2:	Weight Noise Protection Cover .....	81
Table A.3:	Weight Cryogenic Refrigerator Parts .....	81
Table A.4:	Weight Flex Lines .....	81
Table A.5:	Weight Noise Protection Cover .....	81
Table A.6:	Dimensions of Box for the Cryostat .....	82
Table A.7:	Dimensions of Box for the Magnet Stand.....	82
Table A.8:	Dimensions of Box for the Cryogenic Refrigerator.....	82
Table A.9:	Dimensions of Box for the Flex Lines .....	82
Table A.10:	Dimensions of Box for the Noise Protection Cover.....	82
Table A.11:	Environmental conditions .....	83
Table A.12:	Dimension Cryostat - Front View .....	85
Table A.13:	Dimensions Cryostat - Top View .....	86
Table A.14:	Installation Consumption.....	87
Table A.15:	Cryogenic Agents.....	87
Table A.16:	Helium Level Sensor .....	89
Table A.17:	Characteristic Values PT 100.....	90
Table A.18:	Characteristic Values IBT .....	91
Table A.19:	Specification of the Magnet.....	93
Table A.20:	Resistance at Room Temperature .....	99
Table A.21:	Heater currents .....	100
Table A.22:	Energizing assignment and currents.....	100
Table A.23:	Energizing currents .....	101
Table A.24:	Cycling assignment (recommended only for 500 Mhz and more).....	102
Table A.25:	De-energizing Assignment and Currents .....	103
Table A.26:	Fringe Field Values .....	106



## A.4 Glossary / Abbreviations

---

Used term	Description
Box	Any kind of package used to protect sensitive parts during transportation.
Cryostat	The collective of all parts providing a temperature of 4 K inside for the superconducting magnet. The cryostat also provides the safety devices and the access ports for the cryogenic agents and electricity. The superconducting magnet inside the cryostat is not energized.
Dewar	Any kind of package used for transporting cryogenic agents like gaseous or liquid helium or nitrogen.
Magnet System	The collective of all parts necessary for the intended use. The superconducting magnet inside the cryostat is energized.

Abbreviations	Description
ACD	Automatic Cooling Device
BSMS	Bruker Smart Magnetcontrol System
BSVT	Bruker Smart Variable Temperature System
MICS	Magnet Information and Control System; Bruker Corporation registered trademark
NMR	Nuclear Magnetic Resonance
RS	Radiation Shield
RT	Room Temperature; used for room temperature level and as prefix of parts witch are at room temperature
VTA	Variable Temperature Adapter
USR	Ultra Shielded Refrigerated; Bruker Corporation registered trademark



## A.5 Technical Data MS 400'54 Ascend /R

### A.5.1 Dimensions

#### Weights

<b>Cryostat</b>	<b>Value</b>	<b>Unit</b>
Weight, empty, without magnet stand	446	kg
Weight, completely filled, without magnet stand	481	kg
Weight, empty, ready for transportation including box	595	kg

Table A.1: Weight Cryostat

<b>Magnet Stand</b>	<b>Value</b>	<b>Unit</b>
Weight, ready for use	112	kg
Weight, ready for transportation including box	169	kg

Table A.2: Weight Noise Protection Cover

<b>Cryogenic Refrigerator Parts</b>	<b>Value</b>	<b>Unit</b>
Weight, Cryogenic Refrigerator Parts	140	kg
Weight, Rotary Valve Column	60	kg
Weight, ready for transportation including box	345	kg

Table A.3: Weight Cryogenic Refrigerator Parts

<b>Flex Lines</b>	<b>Value</b>	<b>Unit</b>
Weight, ready for use	50	kg
Weight, empty, ready for transportation including box	65	kg

Table A.4: Weight Flex Lines

<b>Noise Protection Cover</b>	<b>Value</b>	<b>Unit</b>
Weight, ready for use	25	kg
Weight, empty, ready for transportation including box	41	kg

Table A.5: Weight Noise Protection Cover

## Dimensions of Transportation Boxes

<b>Cryostat</b>	<b>Value</b>	<b>Unit</b>
Height	1800	mm
Width	1050	mm
Depth	1260	mm

Table A.6: Dimensions of Box for the Cryostat

<b>Magnet Stand</b>	<b>Value</b>	<b>Unit</b>
Height	950	mm
Width	730	mm
Depth	1150	mm

Table A.7: Dimensions of Box for the Magnet Stand

<b>Cryogenic Refrigerator Parts</b>	<b>Value</b>	<b>Unit</b>
Height	950	mm
Width	730	mm
Depth	1150	mm

Table A.8: Dimensions of Box for the Cryogenic Refrigerator

<b>Flex Lines</b>	<b>Value</b>	<b>Unit</b>
Height	950	mm
Width	730	mm
Depth	1150	mm

Table A.9: Dimensions of Box for the Flex Lines

<b>Noise Protection Cover</b>	<b>Value</b>	<b>Unit</b>
Height	900	mm
Width	800	mm
Depth	1200	mm

Table A.10: Dimensions of Box for the Noise Protection Cover

### Environmental conditions

	Value	Unit
Minimum surrounding temperature	7	°C
Maximum surrounding temperature	38	°C
Maximum relative humidity up to 31°C	80	%
Maximum relative humidity between 31°C and 40°C linear decreasing	80-50	%

Table A.11: Environmental conditions

### Identification Plate

The identification plate is on the right back side of the cryostat fixed at the bottom plate.

#### Contents of the identification plate:

- Address of the Manufacturer
- Magnet System Identifier
- Type
- Identification Number
- Magnet Identifier
- Serial Number
- Year of Construction
- Cryostat Identifier
- Specification Helium Vessel
- Specification Vacuum Chamber
- Weight (empty and completely filled) including magnet stand

Dimensions Cryostat

Front view

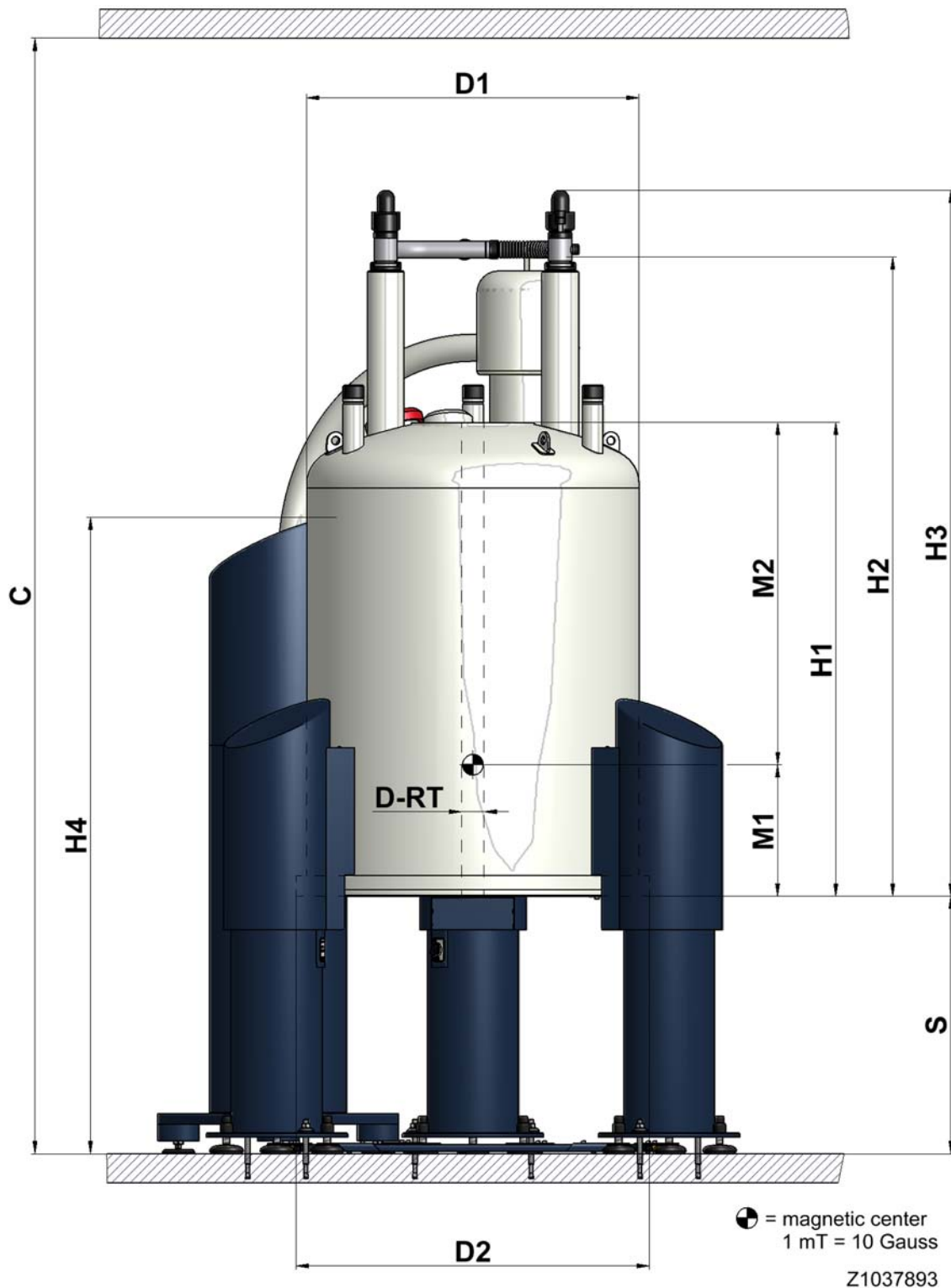

Figure A.1: Dimension Cryostat - Front View

Dimensions Cryostat	Value	Unit
C Operational Ceiling Height	2657	mm
D-RT Diameter RT Bore Tube	54	mm
D1 Diameter RT vessel	800	mm
D2 Diameter Bottom Plate	850	mm
H1 Height Cryostat (bottom plate to top flange)	1140	mm
H2 Height Cryostat (minimum height for transportation)	1538	mm
H3 Height Cryostat (bottom plate to flow system)	1695	mm
H4 Height Rotary Valve Column	1530	mm
S Height Magnet Stand (floor to bottom plate)	570	mm
M1 Distance magnetic Center to bottom flange (calculated)	317	mm
M2 Distance magnetic center to top flange (calculated)	823	mm

Table A.12: Dimension Cryostat - Front View

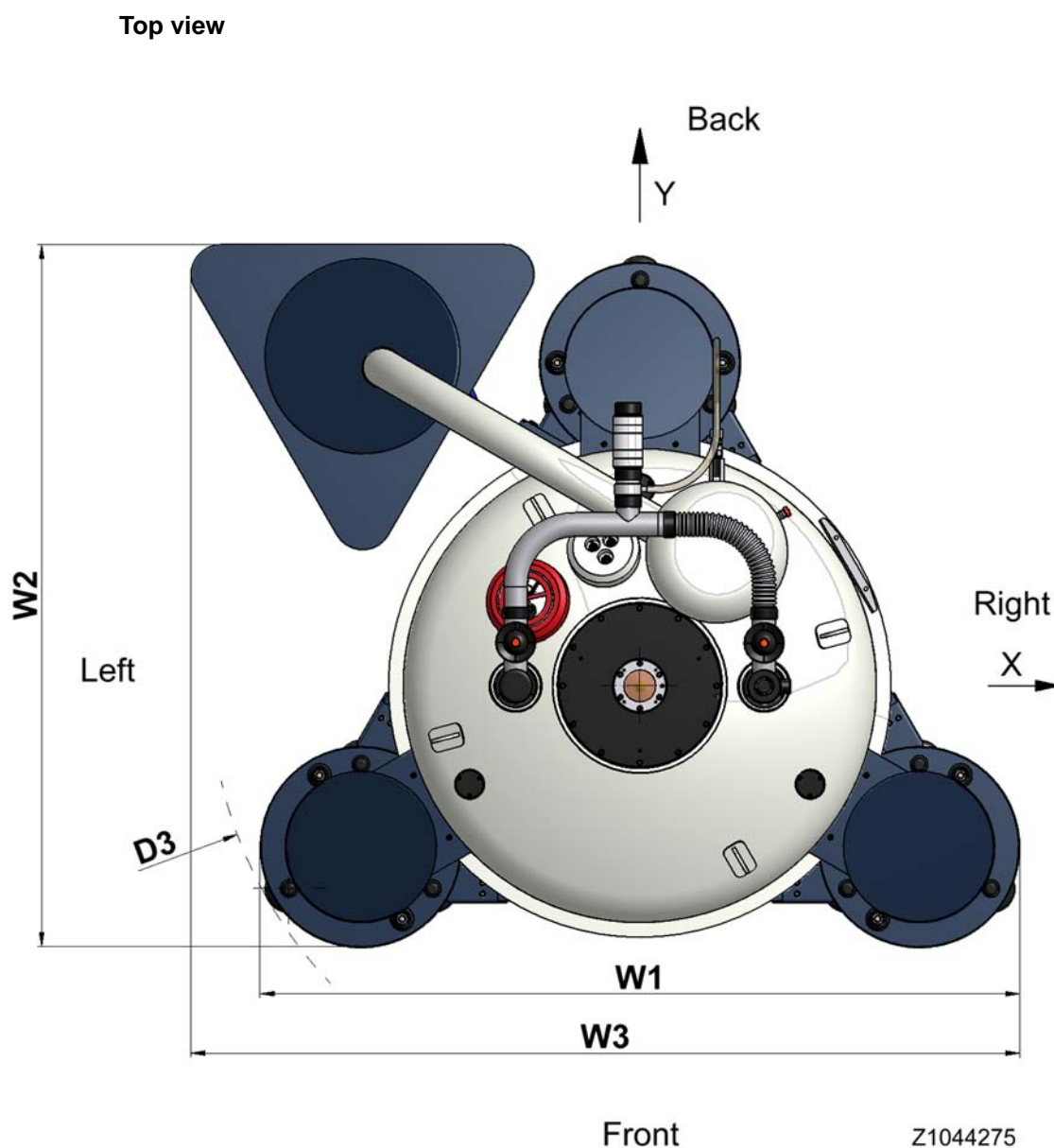

Figure A.2: Dimension Cryostat - Top View

Dimensions Cryostat	Value	Unit
W1	1284	mm
W2	1186	mm
W3	1401	mm
D3 <sup>1</sup>	1451	mm

Table A.13: Dimensions Cryostat - Top View

1. Keep at least an additional free space of 1.5 m around the magnet system for service.

## A.5.2 Technical Data Cryostat

### Supplies during installation

The consumption of liquid cryogenic agents during installation consists of consumption for cooling down the cryostat and the volume to fill the vessels.

Cryogenic Agent	Value	Unit
Nitrogen	400	l
Helium	400	l
Helium Gas (@200 bar, purity 5.0)	50	l

Table A.14: Installation Consumption

### Fill Volume, Evaporation Rate and Hold Time

Cryogenic Agents	Value	Unit
Helium vessel total volume	280	l
Helium refill volume	141	l
Helium evaporation rate	18.1	ml/h
Helium hold time <sup>1</sup> with Cryogenic Refrigerator operating	460	days
Helium hold time without Cryogenic Refrigerator operating (at minimum allowed helium level)	7	days
Helium refill volume after Quench (cool down and refill)	200	l

Table A.15: Cryogenic Agents

1. Maximum time interval between two fillings

### Helium Level Graph

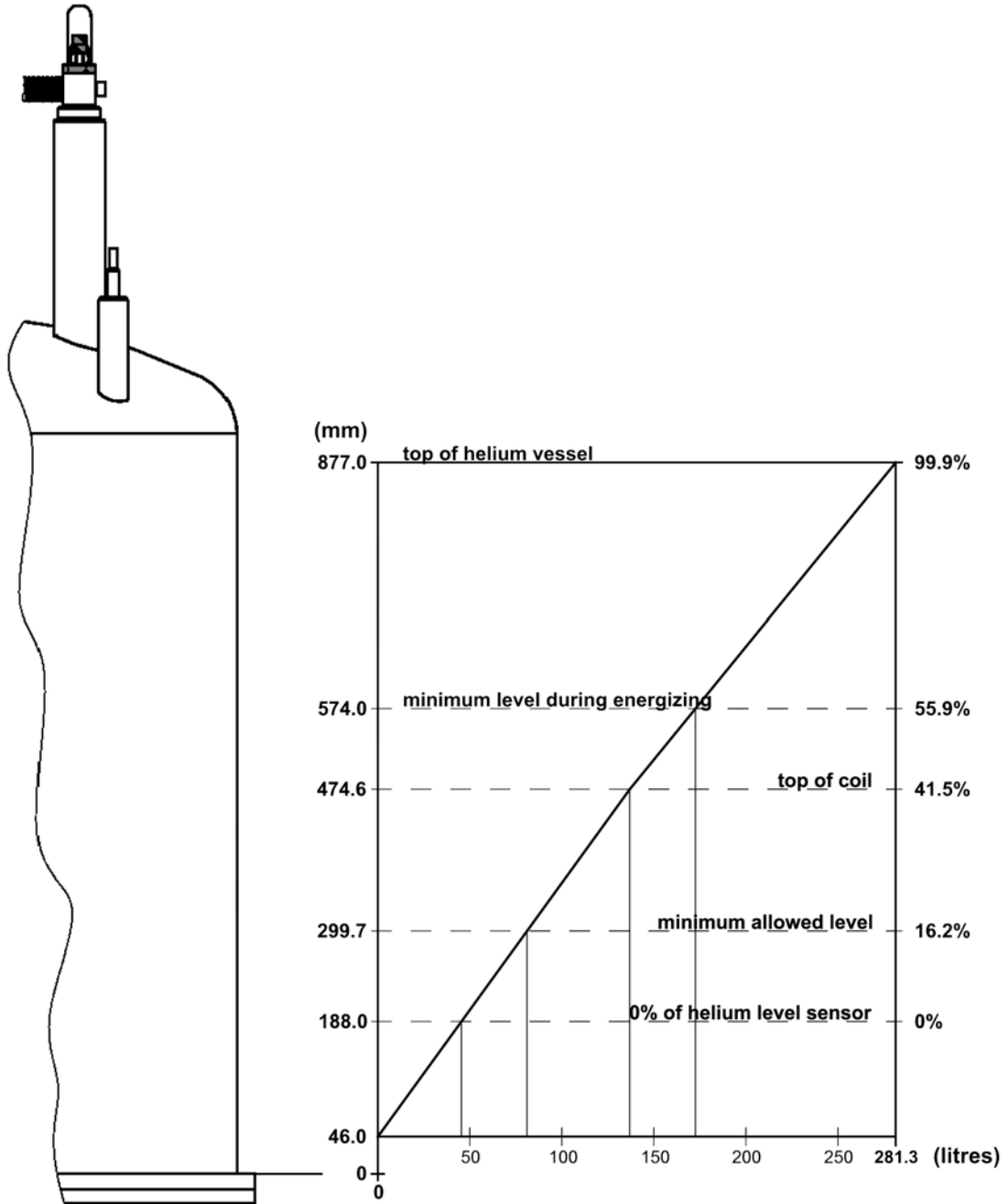

Figure A.3: Helium Level Graph

### Helium Level Sensor

The helium level sensor is inserted in the helium fill-in turret.

Helium Level Sensor	Material No.	Value	Unit
Level Sensor Type	Z58114	1300/690	
Overall length		1300	mm
Active length		690	mm
Calibration 0 %, Calibration resistor	Z28630 blue	140	$\Omega$
Calibration 100 %, Calibration resistor	Z28628 black	15	$\Omega$

Table A.16: Helium Level Sensor

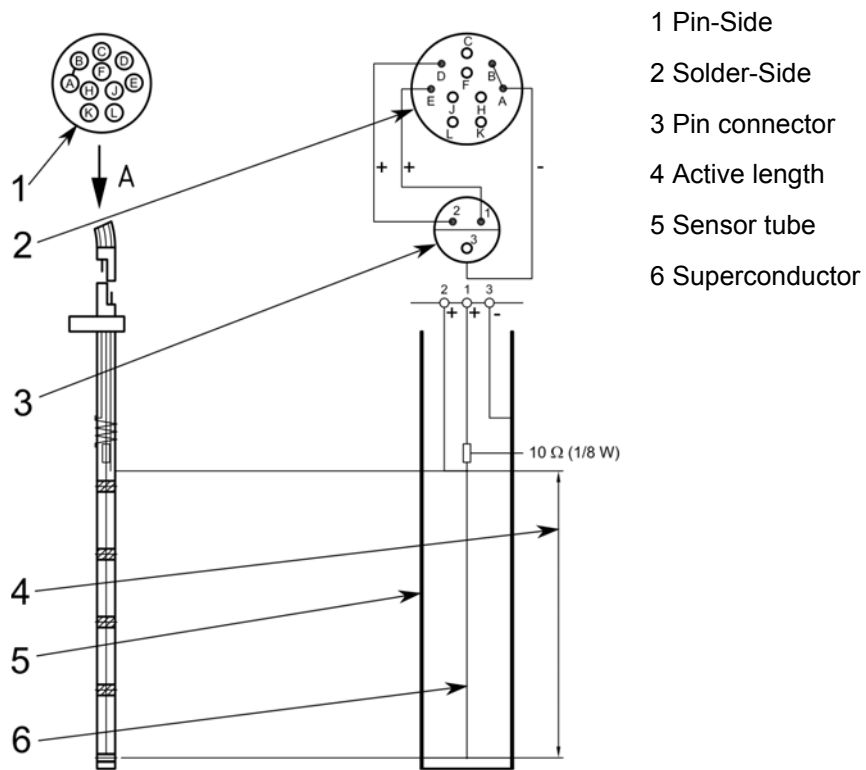

Z1029564

Figure A.4: Helium Level Sensor

## Temperature Sensors

The temperature sensors (PT 100 and IBT) will be used to monitor the temperature of the magnets during cooling and warming up of the magnet system.

### PT 100

**i** Measure the resistance with a maximum current of 1 mA.

	Temperature	Unit	Resistance	Unit
Room Temperature	293	K	107.8	Ω
	273	K	100.0	Ω
	250	K	91.0	Ω
	200	K	71.1	Ω
	150	K	50.9	Ω
	100	K	30.0	Ω
Liquid Nitrogen	77	K	20.1	Ω

Table A.17: Characteristic Values PT 100

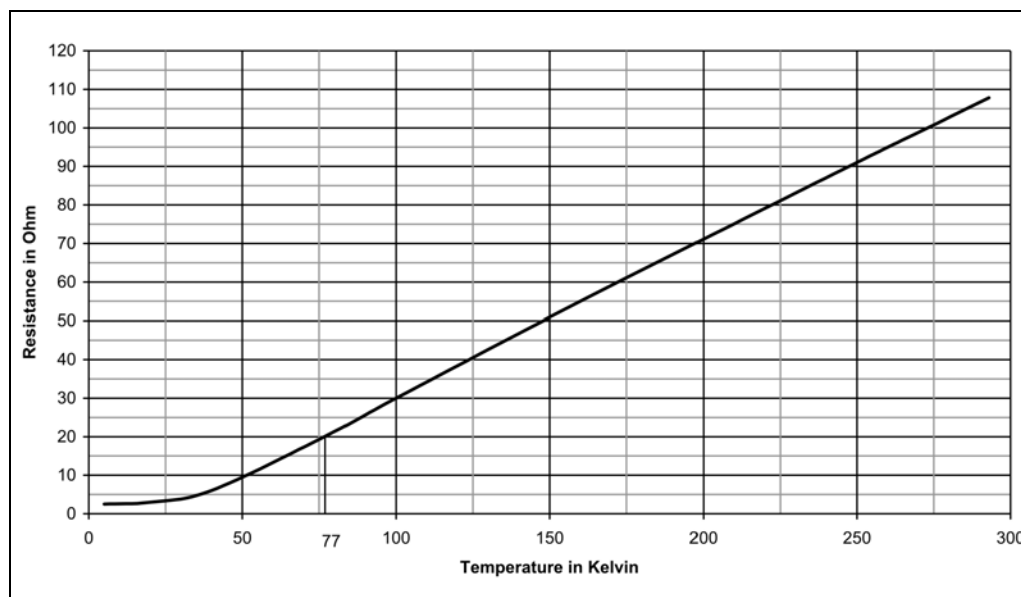

Figure A.5: Characteristic Curve PT 100

### IBT Carbon Resistor

**i** Measure the Resistance with a maximum current of 0.1 mA.

	Temperature	Unit	Resistance	Unit
Room Temperature	300	K	220	Ω
Liquid Nitrogen	77	K	265	Ω
	40	K	300	Ω
	20	K	350	Ω
	10	K	420	Ω
	8	K	450	Ω
	6	K	500	Ω
	5	K	540	Ω
Liquid Helium	4.2	K	575	Ω

Table A.18: Characteristic Values IBT

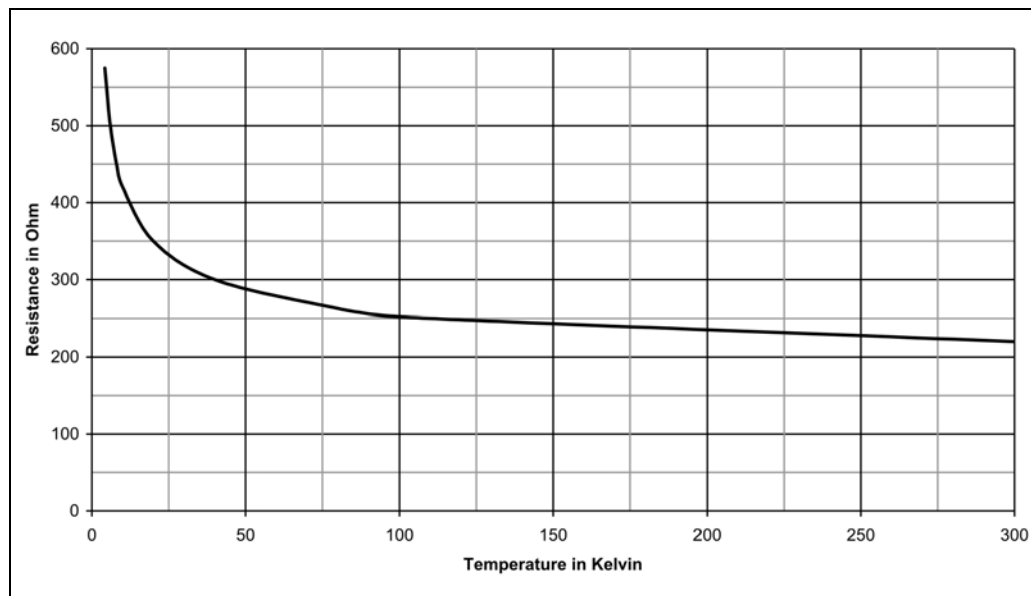
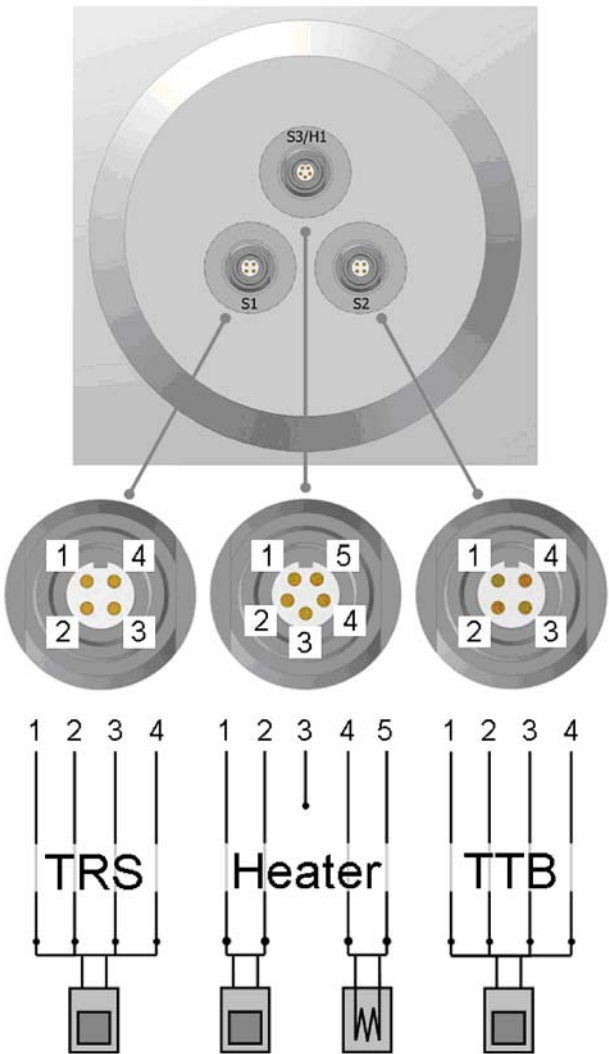

Figure A.6: Characteristic Curve IBT

### Wiring Diagramm Temperature Sensors



View from outside Feedthrough Plate

Figure A.7: Wiring Diagramm Temperature Sensors

### A.5.3 Technical Data Magnet

Technical Data Magnet	Value	Unit
Proton frequency	400	MHz
Central field	9.4	T
Coil inductance	29.8	H
Magnetic energy	166	kJ
Magnetic centre from bottom flange (design value)	317	mm
Maximum drift rate	10	ppm/h
	4	Hz/h
Radial fringe field at 0.5 mT	0.5	m
Axial fringe field at 0.5 mT	1.0	m

Table A.19: Specification of the Magnet

#### Operating modes of the Magnet System:

##### Driven Mode

In the driven mode the current lead is mounted and the electricity is flowing through the power supply. The coils of the magnet can be charged and discharged.

##### Persistent Mode

In the persistent mode the electricity is flowing exclusively within the magnet. The circuit has no connection to the outside. The magnetic field cannot be switched off.

Current Lead

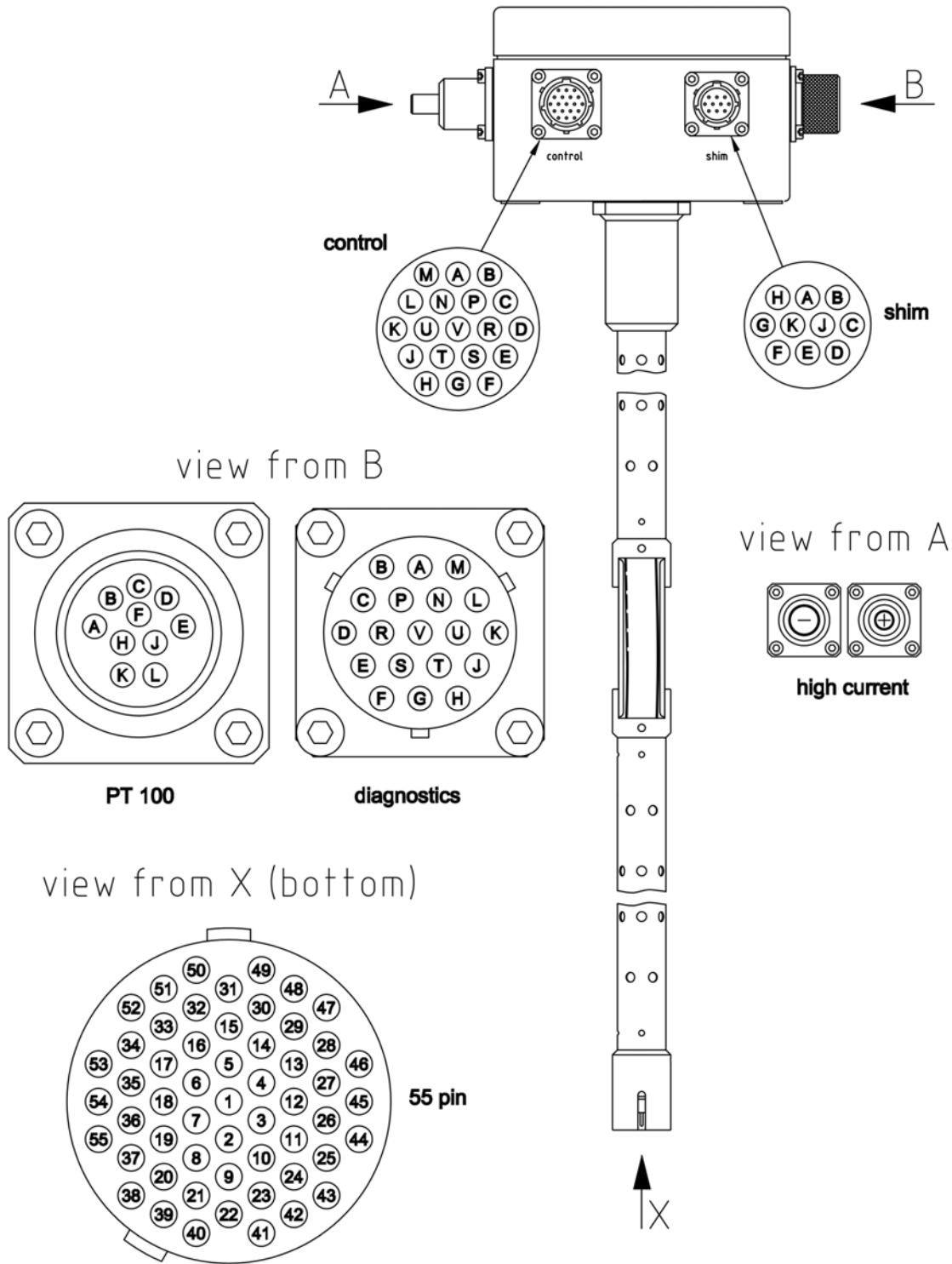

Z1029367

Figure A.8: Current Lead 55 pins

Wiring Diagram Magnet

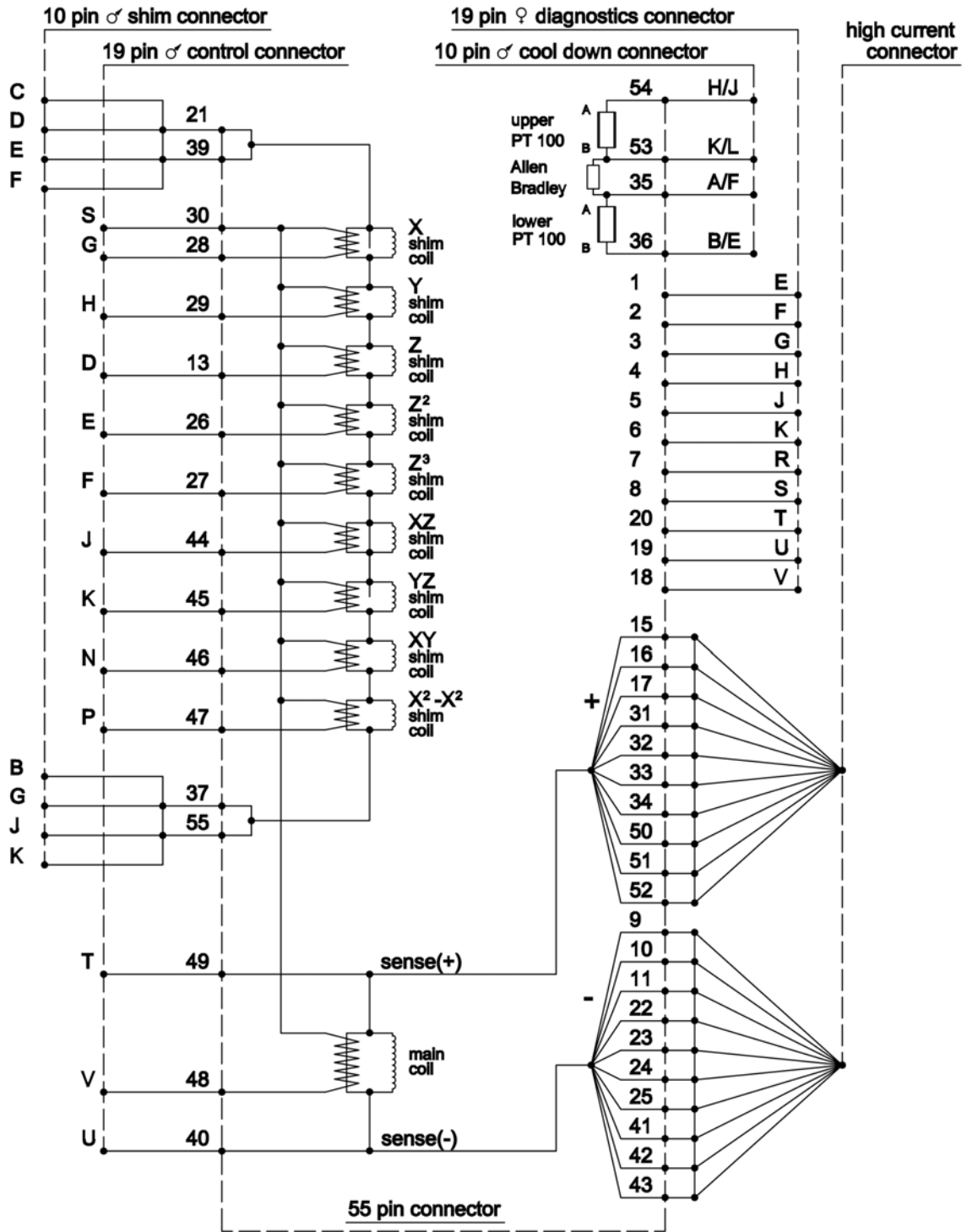

Z1030082

Figure A.9: Wiring Diagram Magnet

Wiring Diagram Magnet Control

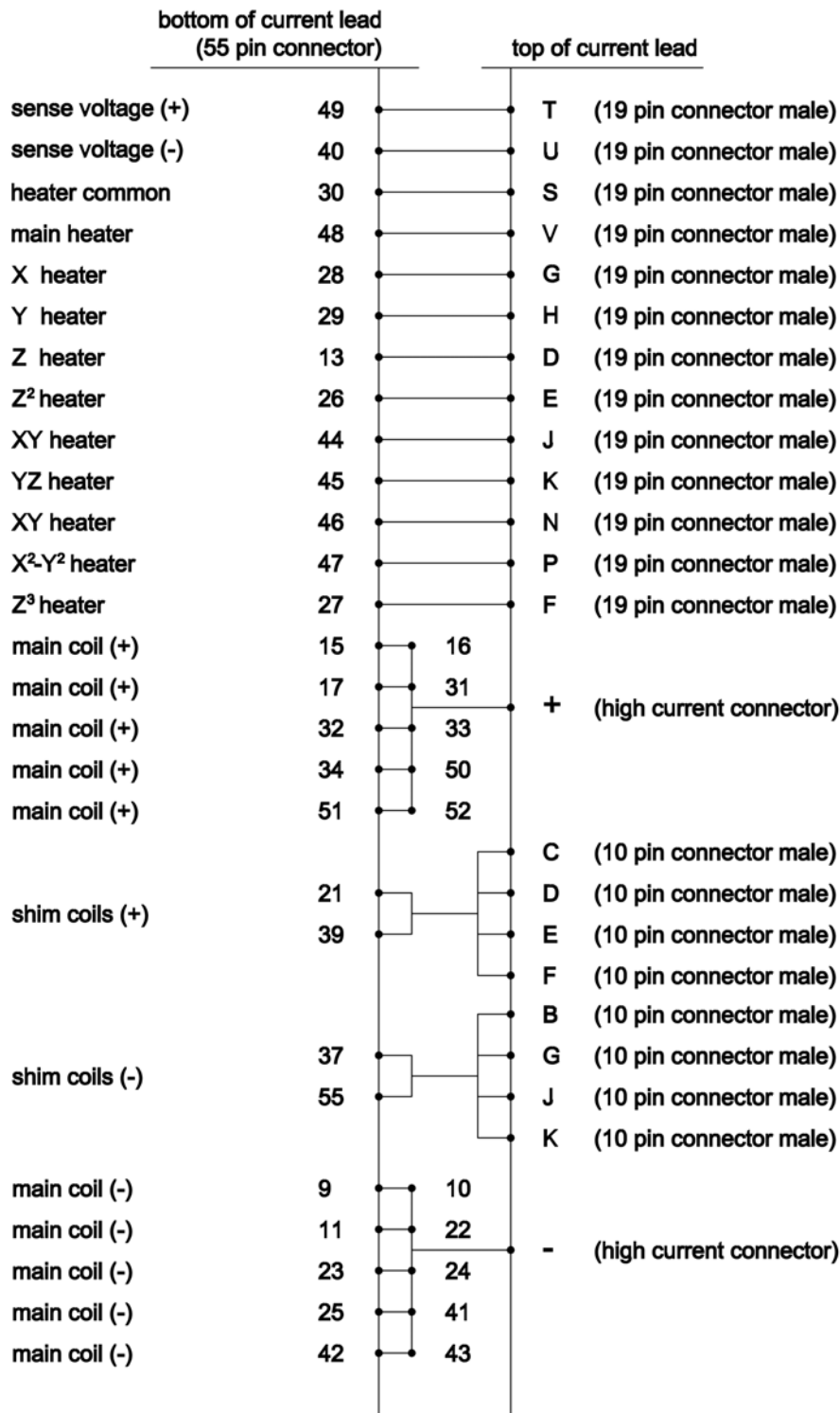

Z1029391

Figure A.10: Wiring Diagram Magnet - Control

Wiring Diagram Magnet Diagnostic and Temperature Sensors

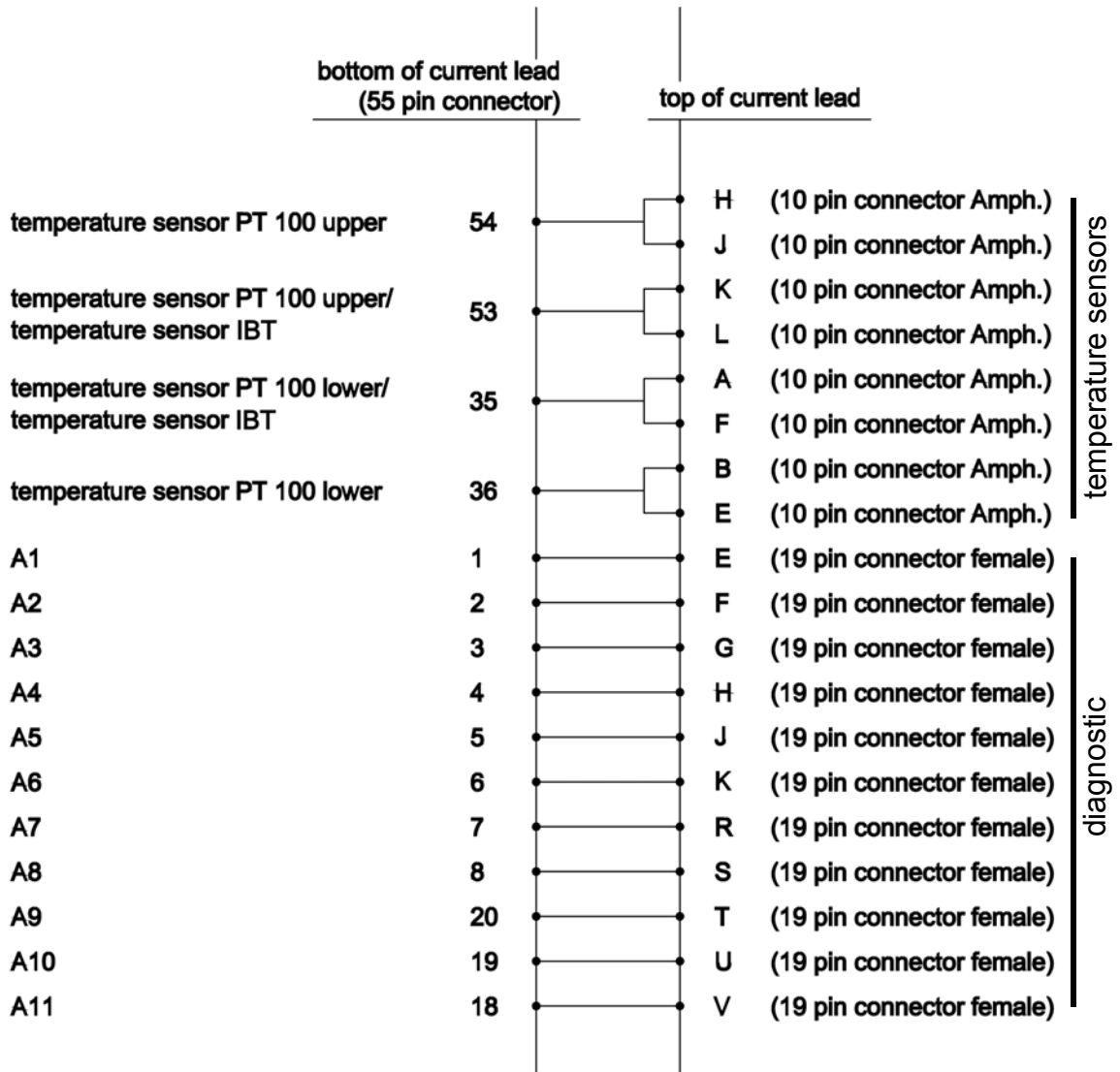

Z1029392

Figure A.11: Wiring Diagram Magnet - Diagnostic and Temperature Sensors

This side is intentionally left blank.

**Resistance at Room Temperature**

	Pin	Connector	Description	Value	Unit
From: To:	PIN V PIN S	19 PIN Con CONTROL 19 PIN Con CONTROL	Main Heater		Ω
From: To:	PIN D PIN S	19 PIN Con CONTROL 19 PIN Con CONTROL	Z Heater		Ω
From: To:	PIN G PIN S	19 PIN Con CONTROL 19 PIN Con CONTROL	X Heater		Ω
From: To:	PIN H PIN S	19 PIN Con CONTROL 19 PIN Con CONTROL	Y Heater		Ω
From: To:	PIN J PIN S	19 PIN Con CONTROL 19 PIN Con CONTROL	XZ Heater		Ω
From: To:	PIN K PIN S	19 PIN Con CONTROL 19 PIN Con CONTROL	YZ Heater		Ω
From: To:	PIN N PIN S	19 PIN Con CONTROL 19 PIN Con CONTROL	XY Heater		Ω
From: To:	PIN P PIN S	19 PIN Con CONTROL 19 PIN Con CONTROL	X <sup>2</sup> -Y <sup>2</sup> Heater		Ω
From: To:	PIN E PIN S	19 PIN Con CONTROL 19 PIN Con CONTROL	Z <sup>2</sup> Heater		Ω
From: To:	PIN F PIN S	19 PIN Con CONTROL 19 PIN Con CONTROL	Z <sup>3</sup> Heater		Ω
From: To:	PIN C,D,E,F PIN B,G,J,K	10 PIN Con SHIM 10 PIN Con SHIM	Shim Coils +/-		Ω
From: To:	+ PIN T	High current Con 19 PIN Con CONTROL	High Current to Sense +		Ω
From: To:	+ -	High current Con High current Con	Main Coil		Ω
From: To:	- PIN U	High current Con 19 PIN Con CONTROL	High Current to Sense -		Ω
From: To:	PIN T PIN U	19 PIN Con CONTROL 19 PIN Con CONTROL	Sense + Sense -		Ω
From: To:	PIN C PIN S	10 PIN Con SHIM 19 PIN Con CONTROL	Shim Coil to Heater (common)		Ω
From: To:	PIN C PIN T	10 PIN Con SHIM 19 PIN Con CONTROL	Shim Coil to Main Coil		Ω
From: To:	PIN T PIN S	19 PIN Con CONTROL 19 PIN Con CONTROL	Sense to Heater (common)		Ω
From: To:		All Connectors Ground	Insulation Magnet to Cryostat		Ω
From: To:	PIN K PIN H	10 Pin cool down Con 10 Pin cool down Con	Upper temperature sensor PT 100		Ω
From: To:	PIN A PIN K	10 Pin cool down Con 10 Pin cool down Con	IBT Carbon temperature sensor		Ω
From: To:	PIN A PIN B	10 Pin cool down Con 10 Pin cool down Con	Lower temperature sensor PT100		Ω

Table A.20: Resistance at Room Temperature

### Heater Currents



Heater Currents	Value	Unit
Main heater current		A
Shim heater current		A

Table A.21: Heater currents

### Energizing Assignment and Currents

Check the "minimum helium level for energizing" (see page A.5-88)

During energizing the Z<sup>2</sup> shim heater must be permanently ON.

Energizing Currents [A]			Sense voltage [mV]	Remarks Bruker Test Site
0	to	120	4000	
120	to	170	2000	
170	to	190	1000	
190	to	205	500	
205	to		200	
<b>Overshoot (0.25 % of final current)</b>				
	to		50	
<b>10 Minutes break at overshoot current</b>				
	to		-50	
<b>Total energizing time [min]</b>				

Table A.22: Energizing assignment and currents

**Energizing Currents**

-----

<b>Energizing Currents</b>	<b>Value Bruker Test Site</b>	<b>Value Customer Site #1</b>	<b>Value Customer Site #2</b>	<b>Unit</b>
Magnet main current				A
Z-Shim current				A
Z <sup>2</sup> -Shim current				A
Z <sup>3</sup> -Shim current				A
X-Shim current				A
Y-Shim current				A
XZ-Shim current				A
YZ-Shim current				A
XY-Shim current				A
X <sup>2</sup> -Y <sup>2</sup> -Shim current				A
Magnetic center from bottom flange (measured)				mm
Magnetic center from top flange (measured)				mm
Date and Signature				

Table A.23: Energizing currents

**Cycling Assignment and Shim Currents**

(recommended only for 500 MHz and more)



Cycling Assignment and Shim Currents	Value	Unit
Time between energizing and cycling (at least 12 h)		h
Time between cycling and shimming (at least 12 h)		h
Current rate		A/h
Z-Shim current		A
Z <sup>2</sup> -Shim current		A
Z <sup>3</sup> -Shim current		A
X-Shim current		A
Y-Shim current		A
XZ-Shim current		A
YZ-Shim current		A
XY-Shim current		A
X <sup>2</sup> -Y <sup>2</sup> -Shim current		A
Frequency change due to cycling		kHz
Date and Signature		

Table A.24: Cycling assignment (recommended only for 500 Mhz and more)

De-energizing Assignment and Currents

-----

Deenergizing Currents [A]			Sense voltage [mV]	Remarks Bruker Test Site
	to	205	400	
205	to	190	1000	
190	to	0	2000	through external diodes
<b>Total de-energizing time [min]</b>				

Table A.25: De-energizing Assignment and Currents

This side is intentionally left blank.

### Shorting Plug

The shorting plug is plugged after removal of the current lead. After inserting the shorting plug the current flows through the shorting plug and no longer through the current lead and the power supply.

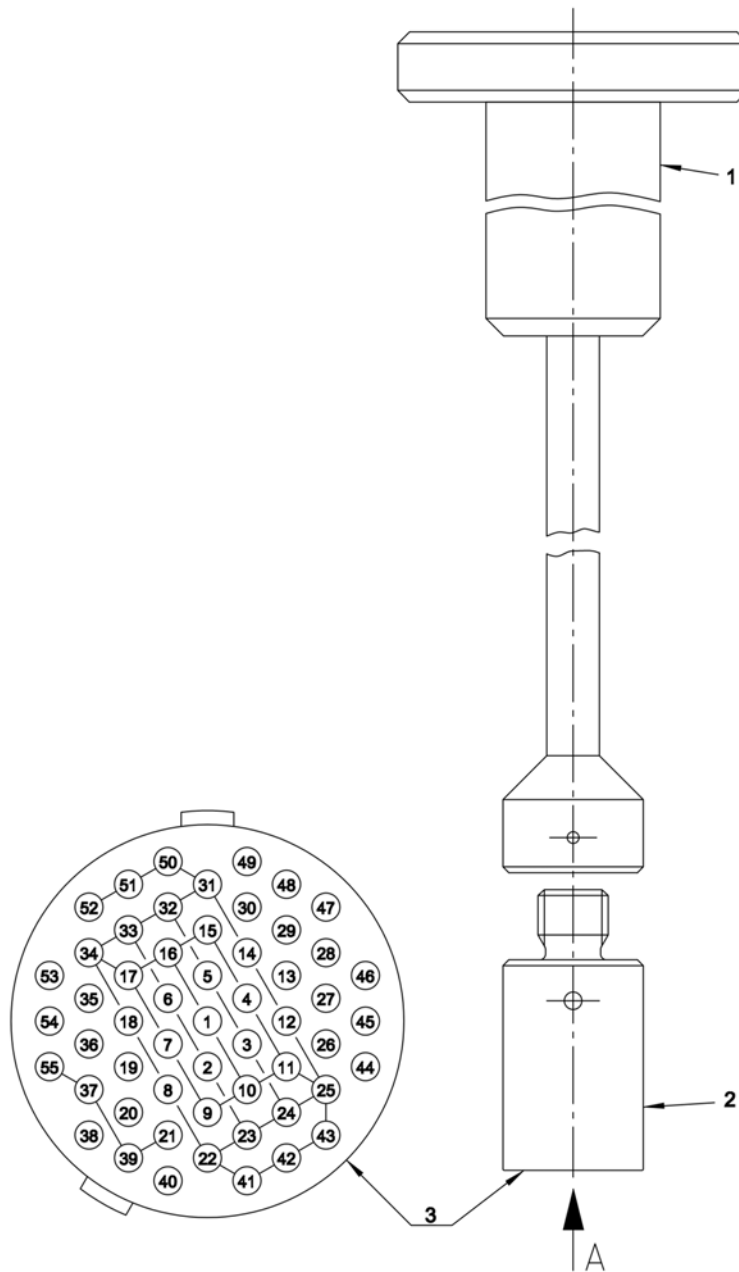

Z1029521

Figure A.12: Shorting Plug 55 pins

1 Shorting Plug Tool for fitting and removing the shorting plug

2 Shorting Plug

3 Shorting Plug - view from pin side

**Fringe Field Plot**

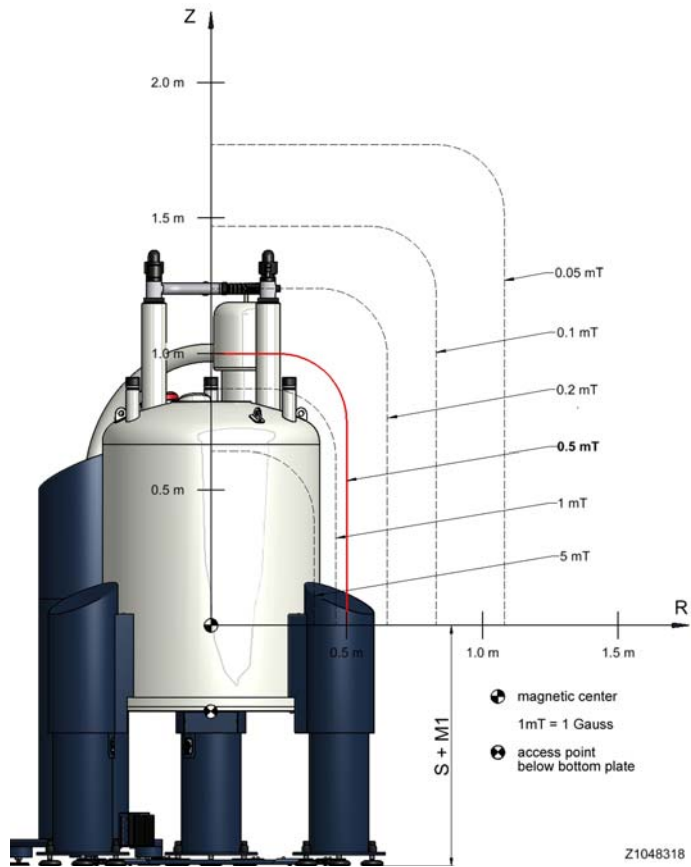

Figure A.13: Fringe field plot

Fringe Field	Unit	R max	Unit	Z max	Unit
200	mT	0.21	m	0.34	m
5.0	mT	0.38	m	0.64	m
3.0	mT	0.41	m	0.70	m
0.1	mT	0.46	m	0.87	m
0.5	mT	0.50	m	1.00	m
0.2	mT	0.65	m	1.24	m
0.1	mT	0.83	m	1.47	m
0.05	mT	1.08	m	1.77	m
<b>max magnetic field B0 at access point</b>				<b>280</b>	<b>mT</b>
<b>max field gradient dB/dz at access point</b>				<b>5.4</b>	<b>T/m</b>

Table A.26: Fringe Field Values





## A.6 Index

---

### A

Attachment Points ..... 34

### C

Cleaning Staff ..... 16

Cold Head ..... 12

Complaint Process ..... 32

Compressor ..... 12

Connection Line ..... 12

Cryogenic Agents ..... 20, 21

Cryogenic Refrigerator ..... 13, 64

### D

Disturbances ..... 50

Drop-off Plate ..... 29

### E

Electricity ..... 21

Emergency ..... 30

Emergency Exit ..... 27

### F

Fire Department ..... 30

First Aid for Cold Burns ..... 30

Flex Lines ..... 12

### I

Identification Plate ..... 83

Intended Use ..... 18

### L

Liability ..... 11

Low Temperatures ..... 23

### M

Magnet Stand ..... 12

Magnetic Field ..... 20

### O

One-way Valves ..... 29

### P

Portable Oxygen Monitor ..... 26

Protective Clothes ..... 26

Protective Gloves ..... 26

Protective Goggles ..... 26

## Q

Quench .....	22, 61
Quench Valve .....	29

## R

Rescue Equipment .....	30
Rotary Valve Column .....	12

## S

Safety Devices .....	28
Safety Shoes .....	26
Shock Watch .....	32
Slippage .....	23
Spontaneous Ignition .....	23

## T

Tilt Watch .....	32
Tilting .....	24

## W

Warranty .....	11
----------------	----

## Revision History List

<b>Index:</b>	<b>Date:</b>	<b>Alteration Type:</b>
00	January 2012	First release.



# Bruker, your solution partner

Bruker provides a world class, market leading range of analytical solutions for your molecular and material research needs. Our solution-oriented approach enables us to work closely with you to identify your specific needs and determine the best solution package for you from our comprehensive range. Furthermore, we offer you the opportunity to collaborate with us on new developments.

Our ongoing efforts and substantial investment in research and development demonstrate our long term commitment to technological innovation on behalf of our customers. With 50 years of experience in meeting the needs of the scientific community across a range of specialist disciplines, Bruker has built a sound rapport with professionals from the community through understanding specific requirements.

This cooperative relationship with our customers allows us to provide them with effective solutions and a service of unmatched quality.

---

 **Bruker Corporation**

info@bruker.com  
www.bruker.com