

400'54 Ascend

- User Manual

Version 05



Copyright © by Bruker Corporation

All rights reserved. No part of this publication may be reproduced, stored in a retrieval system, or transmitted, in any form, or by any means without the prior consent of the publisher. Product names used are trademarks or registered trademarks of their respective holders.

This manual was written by

Renate Petry

© March 30, 2017: Bruker Corporation

Faellanden, Switzerland

ZTKS0162 / Z31928 / 05

For further technical assistance on the NMR Magnet System, please do not hesitate to contact your nearest BRUKER dealer or contact us directly at:

BRUKER BioSpin AG
Industriestrasse 26
CH-8117 Faellanden
Switzerland

Phone: + 41 44 825 91 11
FAX: + 41 44 825 96 96
E-mail: 2nd-level-support.bbio@bruker.com
Internet: www.bruker.com

| | | |
|----------|--|-----------|
| | Contact | 7 |
| 1 | Introduction..... | 9 |
| 1.1 | General Information..... | 9 |
| 1.2 | Limitation of Liability..... | 9 |
| 1.3 | Customer Service..... | 9 |
| 1.4 | Warranty..... | 9 |
| 1.5 | Copyright..... | 9 |
| 1.6 | General View..... | 10 |
| 2 | Safety..... | 11 |
| 2.1 | Approved Persons..... | 11 |
| 2.2 | Customer Responsibilities..... | 12 |
| 2.3 | Key Words..... | 13 |
| 2.4 | Residual Risks..... | 14 |
| 2.4.1 | Persons..... | 14 |
| 2.4.2 | Intended Use..... | 14 |
| 2.4.3 | Safety Devices..... | 15 |
| 2.4.4 | Spare Parts..... | 15 |
| 2.4.5 | Signs and Labels..... | 16 |
| 2.4.6 | Technical Risks..... | 16 |
| 2.5 | Personal Protective Equipment..... | 22 |
| 2.6 | Description of Signs and Labels..... | 23 |
| 2.7 | Safety Devices..... | 24 |
| 2.8 | Behavior in Danger and Emergency Situations..... | 26 |
| 2.9 | Fire Department Notification..... | 26 |
| 3 | Transportation..... | 27 |
| 3.1 | Safety..... | 27 |
| 3.2 | Packaging..... | 27 |
| 3.2.1 | Disposal..... | 28 |
| 3.3 | Transport Inspection..... | 28 |
| 3.4 | Transportation by Fork Lift / Pallet Jack..... | 29 |
| 3.5 | Transportation with a Crane..... | 30 |
| 3.6 | Storing..... | 31 |
| 3.7 | Disposal..... | 31 |
| 4 | Assembly..... | 33 |
| 4.1 | Safety..... | 33 |
| 5 | Operation..... | 35 |
| 5.1 | Safety..... | 35 |

| | | |
|----------|---|-----------|
| 5.2 | Set into Operation..... | 36 |
| 6 | Troubleshooting | 37 |
| 6.1 | Safety | 37 |
| 6.2 | Problem | 38 |
| 6.2.1 | During Transportation..... | 38 |
| 6.2.2 | During Assembly | 38 |
| 6.2.3 | During Cooling Procedure | 40 |
| 6.2.4 | During Energizing and Shimming..... | 44 |
| 6.2.5 | During Operation of the Magnet Stand..... | 47 |
| 6.2.6 | During Standard Operation..... | 49 |
| 6.2.7 | During De-energizing and Warming | 51 |
| 6.3 | Troubleshooting Work | 52 |
| 6.3.1 | After a Quench | 52 |
| 7 | Maintenance..... | 53 |
| 7.1 | Safety | 53 |
| 7.2 | Cleaning | 53 |
| 7.3 | Maintenance Timetable | 54 |
| 7.4 | Maintenance-free Components | 54 |
| 8 | Disassembly..... | 55 |
| 8.1 | Safety | 55 |
| 9 | Technical Data MS 400'54 Ascend..... | 57 |
| 9.1 | Environmental Conditions..... | 57 |
| 9.2 | Identification Plate | 57 |
| 9.3 | Dimensions..... | 58 |
| 9.3.1 | Weights..... | 58 |
| 9.3.2 | Dimensions for Transportation | 58 |
| 9.3.3 | Dimensions Cryostat | 59 |
| 9.4 | Safety Valves..... | 62 |
| 9.5 | Nitrogen Level Sensor | 63 |
| 9.6 | Helium Level Sensor | 64 |
| 9.7 | Temperature Sensors..... | 65 |
| 9.8 | Technical Data Magnet..... | 67 |
| 9.9 | Fringe Field Plot | 68 |
| 9.10 | Filling Volume, Evaporation Rate and Hold Time..... | 69 |
| 9.11 | Nitrogen Level Graph | 70 |
| 9.12 | Helium Level Graph..... | 71 |
| 9.13 | Resistance at Room Temperature..... | 72 |
| 9.14 | Heater Currents | 73 |

| | | |
|-----------------------------|--|---------------|
| 9.15 | Shim Switch Heater | 73 |
| 9.16 | Energizing Assignment and Currents | 74 |
| 9.17 | Magnetic Center | 75 |
| 9.18 | Cycling Assignment and Shim Currents | 76 |
| 9.19 | Energizing Currents | 77 |
| 9.20 | Deenergizing Assignment and Currents | 77 |
| 9.21 | Current Lead | 79 |
| 9.21.1 | Wiring Diagram Magnet | 80 |
| 9.21.2 | Wiring Diagram Magnet Control and Shims | 81 |
| 9.21.3 | Wiring Diagram Magnet Diagnostic and Temperature Sensors | 82 |
| 9.21.4 | Shorting Plug | 83 |
| 9.22 | Nitrogen Refill Report | 84 |
| 9.23 | Helium Refill Report | 86 |
| Appendix A | | 89 |
| A.1 | Warning Signs | 89 |
| A.2 | Figures | 91 |
| A.3 | Tables | 93 |
| A.4 | Glossary / Abbreviations | 95 |

Contact

Manufacturer

Bruker BioSpin AG

Industriestrasse 26

CH-8117 Faellanden

Switzerland

Phone: + 41 44 825 91 11

Fax: + 41 44 825 96 96

<http://www.bruker.com>

E-mail: 2nd-level-support.bbio@bruker.com

Please refer to the Model No., Serial No. and Internal Order No. in all correspondence regarding the NMR system or components thereof.

1 Introduction

1.1 General Information

This manual contains important information about the handling of the supplied magnet system used for NMR spectroscopy and its components. The compliance with all safety and handling instructions, the applicable local accident prevention and general safety regulations are necessary for safe work.

This manual is part of the product. It must be kept nearby the magnet system and free access must be ensured at any time. Read the manual carefully before handling the magnet system or its components.

1.2 Limitation of Liability

The information in this manual will take into account the current state of the technology.

The manufacturer assumes no liability for damages resulting from:

- non-compliance with the instructions and all applicable documentation,
- use for purposes not intended,
- not sufficiently approved persons,
- arbitrary changes or modifications and
- use of not approved spare parts or accessories.

1.3 Customer Service

Technical support is provided by Bruker Service via telephone or e-mail. For contact information [see page 7](#) of this document.

1.4 Warranty

The warranty terms can be found in the sales documents of the magnet system and in the Terms and Conditions of Bruker BioSpin AG.

1.5 Copyright

No part of this publication may be reproduced, stored in a retrieval system, or transmitted, in any form or by any means without the prior consent of the publisher. Product names used are trademarks or registered trademarks of their respective holders.

1.6 General View

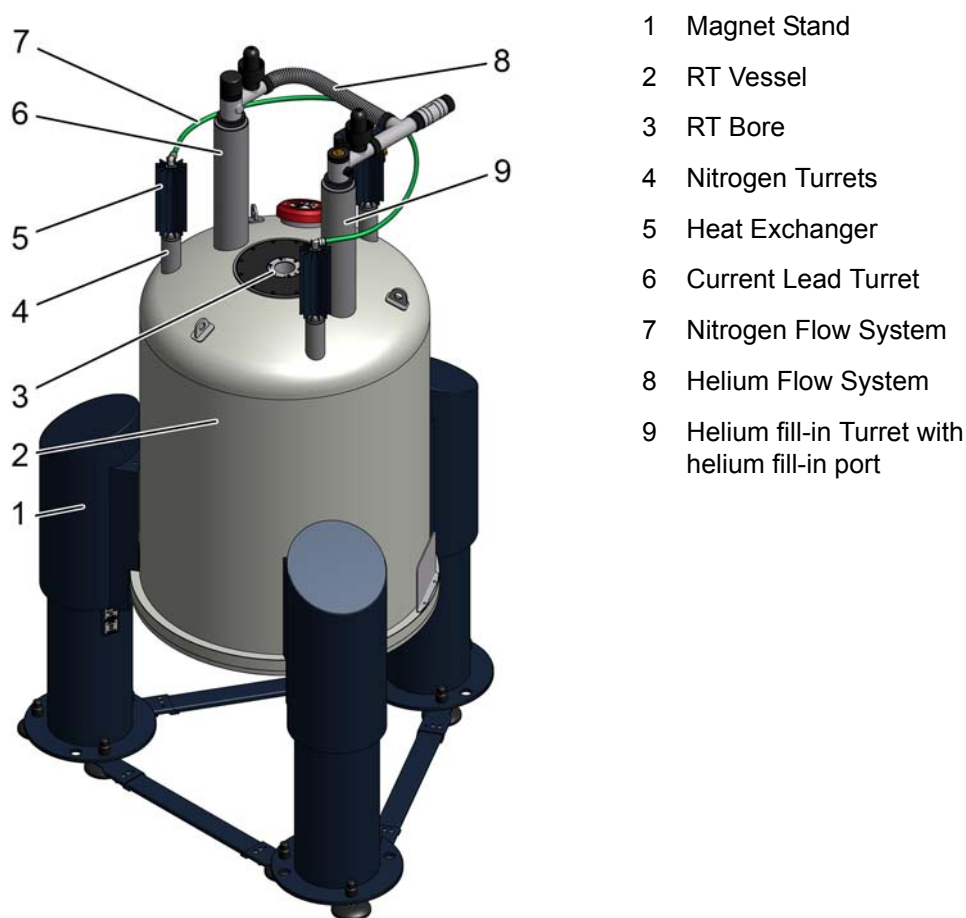

Figure 1.1: General View of a Magnet System with 2 Helium Turrets

The heart of the NMR magnet system is a superconducting magnet located inside the helium vessel, which is filled with liquid helium. The helium vessel is surrounded by a nitrogen vessel filled with liquid nitrogen. The outer casing, the room temperature (RT) vessel (2), contains the helium vessel and the nitrogen vessel. The vacuum in the RT vessel reduces thermal conduction. The RT bore (3) allows the access to the magnetic center. RT vessel, inner vessels, turrets, flow systems and the RT bore together build the cryostat of the magnet system.

The cryostat is mounted on a magnet stand (1). The isolators in the magnet stand absorb floor vibrations. Different heights and isolators are available optionally.

The nitrogen turrets (4) connected with the nitrogen flow system (7) and the heat exchangers (5) are the interface to the nitrogen vessel. The nitrogen fill-in turret is marked with a green label.

The helium turrets (6, 9) connected with the helium flow system (8) are the interface of the helium vessel and the magnet coil. The helium fill-in turret (9) is marked with a yellow label.

The current lead turret (6) is the interface for energizing the magnet coil and for diagnostic.

2 Safety

The supplied cryostat and further equipment of the magnet system were designed and manufactured according to best available technical knowledge and practice, achieved in over 50 years of experience of the Bruker Corporation. International standards for quality and approval recommended for cryostats of superconducting magnets were certified.

Nevertheless non-compliance with the following instructions and safety advice may cause serious hazards and property damage.

2.1 Approved Persons

Bruker BioSpin AG identifies the following qualifications for personnel performing tasks on the magnet system or its components:

Approved Customer Personnel

As a result of professional training by Bruker Service Personnel, experience and knowledge of applicable regulations these persons are qualified to perform the specific tasks on the magnet system and its components assigned to them in this manual. Approved Customer Personnel are qualified to identify possible hazards and risks associated with the tasks assigned to them and to perform all possible steps to eliminate or minimize these risks.

Bruker Service Personnel

These persons are qualified by appropriate qualification and professional training and experience (including all necessary knowledge of applicable regulations and regulatory requirements) to perform specific tasks on the magnet system and its components. Bruker Service Personnel are qualified to identify possible hazards and risks and to perform all possible steps to eliminate or minimize these risks.

2.2 Customer Responsibilities

The customer must obey the security advice and the rules for safety, applicable local accident prevention and environmental protection correctly for the magnet system. Furthermore, the customer is responsible for keeping the magnet system in good technical condition.

In particular:

- The customer must identify additional dangers resulting from the working conditions at the site of the magnet system and provide applicable safety measures.
- The customer must ensure that the site plan meets the specified conditions according to the site planning document for operating the magnet system.
- The customer must clearly mark the danger area around the magnet system and post the corresponding instruction plates.
- The customer has to ensure the intended use of the magnet system.
- The customer has to inform the local fire brigade about the special risks of the magnet system and how to react in the event of an incident.
- The customer must clearly define the responsibilities for operation and maintenance.
- The customer must ensure that all employees working with the magnet system have read and understood the manual.
- The customer has to provide the necessary personal protective equipment for his employees.
- The customer has to instruct his employees at regular intervals on hazards and safety measures.
- The customer has to instruct other persons not working on the magnet system but carrying out work in the same room, for instance cleaning staff or guards about the possible danger at the site of the magnet system.
- The customer must ensure that maintenance is performed according to the schedule listed in chapter [see "Maintenance Timetable" on page 54](#).

2.3 Key Words

Safety instructions in this manual are marked with symbols. The safety instructions are introduced using indicative words which express the extent of the hazard.

In order to avoid accidents, personal injury or damage to property, always observe safety instructions and proceed with care.



! DANGER

This combination of symbol and signal word indicates an immediately hazardous situation which could result in death or serious injury unless avoided.



! WARNING

This combination of symbol and signal word indicates a potentially hazardous situation which could result in death or serious injury unless avoided.



! CAUTION

This combination of symbol and signal word indicates a possibly hazardous situation which could result in minor or slight injury unless avoided.

SAFETY INSTRUCTIONS

This combination of color and signal words is used for control flow and shutdowns in the event of an error or emergency.

NOTICE

This combination of color and signal word indicates a possibly hazardous situation which could result in damage to property or the environment unless avoided.



This symbol highlights useful tips and recommendations as well as information designed to ensure efficient and smooth operation.

2.4 Residual Risks

In the following chapter the residual risks from the risk analysis according ISO 14971 are summarized. To prevent health hazards and hazardous situations obey all safety instructions and warnings in the manual.

2.4.1 Persons

WARNING



Risk of injury and property damage due to handling by not approved persons.

Incorrect handling of the magnet system by not approved persons may result in significant bodily injury and property damage.

Thus:

- Work must only be carried out by approved persons with applicable qualifications. The necessary qualifications are specified in the beginning of the relevant chapter.
- In case of doubt, contact Bruker Service. Contact information [see page 7](#) of this document.

2.4.2 Intended Use

The supplied magnet system is designed and intended for NMR spectroscopy only.

WARNING



Risk of damage to life and limb by incorrect use of the magnet system.

Incorrect use of the magnet system can lead to life-threatening situations and destruction of the magnet system.

Thus:

- Only use the magnet system as intended.
- Do not change the magnet system.
- Do not exceed specified values for operating the magnet system.
- Do not use inserts inside the RT bore not approved by Bruker Service.

Damage claims from damages caused by other than the intended use of the magnet system are excluded and the customer is held liable.

2.4.3 Safety Devices

WARNING



Risk of damage to life and limb due to not sufficient safety devices.

Several safety devices ensure safe operation of the magnet system. They must always be in correct working condition.

Thus:

- Do not block safety devices.
- Do not remove safety devices.
- Check the operational reliability of the safety devices before working on the magnet system.

2.4.4 Spare Parts

WARNING



Risk of injury and property damage from using incorrect or defective spare parts and accessories.

Incorrect or defective spare parts can cause serious injuries. They may cause damaging, malfunctioning and the destruction of the magnet system.

Thus:

- Only use original equipment manufacturer spare parts.
- Only use original equipment manufacturer accessories.

2.4.5 Signs and Labels



WARNING

Risk of damage to persons and property due to not readable signs and labels.

Signs and labels with advice may become not readable.

Thus:

- Maintain signs and labels in a readable state.
- Replace damaged or not readable signs and labels immediately. New signs and labels can be ordered from Bruker Service.

2.4.6 Technical Risks

Magnetic Field



WARNING

Risk of damage to life and limb due to high magnetic fields.

A magnetic field of more than 0.5 mT (5 Gauss) is life-threatening for people with pacemakers or active metal implants. Exposure to more than 8 T can cause damage to health. Duration of exposure (8 h/day) above the limit of 200 mT can cause damage to health. Ferromagnetic tools in the magnetic field are significantly hazardous. Disks and electronic devices may be damaged.

Thus:

- Mark the magnetic field of more than 0.5 mT (5 Gauss) before start up.
- Keep people with active medical implants away from the 0.5 mT (5 Gauss) area.
- The permanent workplace of employees must be outside the 0.5 mT (5 Gauss) area.
- Do not stay or work at magnetic fields of more than 8 T.
- Prevent exposure of more than 200 mT for more than 8 h/day.
- Keep disks, credit cards and electronic devices away from the identified area.
- Do not use ferromagnetic tools or items within the identified area.
- Only use non-ferromagnetic transportation dewars or pressure cylinders for the cryogenic agents.
- Only use non-ferromagnetic ladders or steps.

Cryogenic Agents

WARNING



Risk of damage to life and limb due to cryogenic agents.

Risk of damage to life and limb due to not correct handling of liquid cryogenic agents. Within the transition from liquid to gas, helium and nitrogen expand their volume, causing closed vessels or transportation dewars to burst. The evaporating cryogenic agents will displace the breathing air. Helium displaces the breathing air in the upper part of the room, nitrogen displaces the breathing air in the lower parts of the room. In case of not sufficient ventilation this may result in death by suffocation.

Liquid and gaseous cryogenic agents are extremely cold. Contact with liquid or gaseous cryogenic agents will lead to cold burns. Contact with the eyes may cause blindness. Refer to Warning: Low Temperature on page 21.

Thus:

- Only use cryogenic agents in well ventilated rooms. In case of doubt ask Bruker Service.
- Wear an oxygen monitor on the body during service and maintenance work.
- Prevent any skin contact with liquid or gaseous cryogenic agents.

Electricity

WARNING



Risk of damage to life and limb due to electricity.

Risk of damage to life and limb due to contact with electrical lines and damaged insulation.

Thus:

- Work on electrical equipment must be done by an approved electrical technician.
- Keep moisture away from electrical lines to prevent short-circuits.
- Check the magnet system electrical grounding before start.
- Switch the power OFF before working on the Bruker Power Supply or further equipment.

Quench



WARNING

Risk of suffocation during a quench of the magnet system.

A quench is the very fast de-energizing of the magnet by loss of its superconductivity. The stored magnetic energy is converted into heat and thus large quantities of helium evaporate. The evaporating helium will displace the breathing air. In case of not sufficient ventilation this may result in death by suffocation.

Thus

- The magnet system site must be well ventilated. In case of doubt contact Bruker Service.
- The evaporating gas may resemble smoke. Never pour water on the magnet system.

Gas under Pressure



WARNING

Risk of injury due to gas under pressure inside the cryostat and further equipment.

The helium or the nitrogen vessel of the cryostat may get sealed off due to ice formation inside the helium or the nitrogen turrets in case of non-compliance with the instruction given in this manual. This may lead to overpressure and damage of the helium or the nitrogen vessel.

Manipulations of components with gas under pressure may lead to injury and property damage.

Thus:

- In case of icing inside the helium or the nitrogen turrets contact Bruker Service immediately.
- Release the pressure to the recommended value before working on components with gases under pressure.
- Do not seal cryogenic agent vessels of the magnet system or the transportation dewars.
- Do not connect high pressure transportation dewars to the magnet system. Completely eliminate the high pressure from the transportation dewars before connecting and transferring cryogenic agents.

Low Temperatures

WARNING



Risk of injury due to low temperatures of liquids and metal parts.

Physical contact with extremely cold liquids and metal parts may cause serious injuries. Contact with the skin may cause cold burns. Contact with the eyes may cause blindness.

Thus:

- Always wear protective goggles, protective gloves and protective clothes while handling with liquid cryogenic agents or metal parts in contact with liquid cryogenic agents.
- Protect temperature sensitive components such as O-rings from contact with liquid cryogenic agents.

Spontaneous Ignition and Explosion

WARNING



Risk of injury from spontaneous ignition and explosion caused by liquid oxygen.

Pure oxygen condenses on extremely cold metal pieces. Together with oil it may ignite spontaneously. In case of fire the pure oxygen may cause an explosion.

Thus:

- Do not smoke near the magnet system.
- Do not use open flames near the magnet system.
- Keep the environment around the magnet system clean.
- Do not leave oily rags near the magnet system.

Risk of Slippage

WARNING



Risk of injury from slippage.

The accumulation of condensed water on the floor and ladders causes slippery surfaces.

Thus:

- Always wear safety shoes with an anti-slip sole.
- Be careful using ladders.
- Clean floor and ladders regularly.

Risk of Tilting



WARNING

Risk of injury due to tilting of the magnet system.

The magnet system is very sensitive to lateral forces. It may tilt.

Thus:

- Do not climb onto the magnet system.
- Do not lean items against the magnet system.
- Do not lean against the magnet system.
- Do not move the magnet system on your own.

Heavy Weights



WARNING

Risk of damage to life and limb caused from heavy weights.

Lifting heavy weights is life-threatening due to falling or moving parts.

Thus:

- Do not stay or work under a lifted magnet system.
- All lifting equipment in use must be approved to carry the weight.
- Do not use damaged lifting equipment.
- Do not use lifting equipment without updated check tag.
- Lifting only with approved qualification.
- Obey ergonomic guidelines while lifting heavy parts.
- Protect parts against falling.
- Always wear safety shoes with approved toe caps.

Transportation

CAUTION

Risk of injury and property damage due to incorrect transportation.

The boxes may tilt, movement may get out of control. Thus persons may get injured and the cryostat or further equipment may be damaged.

Thus:

- Be careful while unloading and moving the boxes.
- Do not move the boxes arbitrarily.
- Pay attention to all symbols on the boxes.
- Pay attention to sharp edges and spikes of boxes and parts by using protective gloves while moving.
- Move the boxes in an upright position.
- Do not tilt the boxes.
- Prevent crossing thresholds, even if they are only a few millimeters high.
- Clean the transportation way before moving the box.
- Unpack shortly before assembly.
- The cryostat or further equipment must be protected from rain and other bad weather conditions during transportation.
- Exclusively move the cryostat in its original box.
- Do not remove the tightening straps inside the box until assembly.
- Only use the provided attachment points.
- Ensure that the cryostat is always leveled during any transportation.
- Transportation only with attached transportation locks.
- Do not move the evacuated cryostat.
- Do not move the cryostat after cool down.



2.5 Personal Protective Equipment

The personal protective equipment must be worn at any time while working on the magnet system and further equipment to prevent health hazards.



Protective Goggles

Used to protect the eyes from injury due to flying cold liquids and parts.



Protective Gloves

Used to protect the hands from injury caused by contact with extremely cold liquids or surfaces and for protection from injury caused by rough edges.



Protective Clothes

Used to protect the body from injury caused by contact with extremely cold liquids or surfaces and for protection from wounds.



Safety Shoes

Used to protect the feet from injury from falling of heavy objects. An anti-slip sole protects from injury caused by slipping and falling on slippery floor and steps. Only use safety shoes with non-ferromagnetic toe caps.

Portable Oxygen Monitor and Alarm

Used to warn against low oxygen concentrations in surrounding air.

2.6 Description of Signs and Labels

Signs and labels are always related to their immediate vicinity. The following signs and labels are found on the magnet system and in the vicinity.



Prohibition sign: No person with pacemakers!

People with pacemakers are endangered in the identified area of 0.5 mT (5 Gauss) and are not allowed to enter these areas.



Prohibition sign: No person with implants!

People with metallic implants are endangered in the identified area of 0.5 mT (5 Gauss) and are not allowed to enter these areas.



Prohibition sign: No watches or electronic devices!

Watches and electronic devices may be damaged in the identified area of 0.5 mT (5 Gauss).



Prohibition sign: No credit cards or other magnetic memory!

Credit cards and magnetic memory may be damaged in the identified area of 0.5 mT (5 Gauss).



Prohibition sign: Do not touch! Do not block!

Do not touch or block the identified area.



Hazard warning sign: Strong magnetic field!

- No magnetic memory.
- No jewelry.
- No metallic items.



Helium fill-in port

- Use only this port for helium refill!
- Do not leave the helium ports open for more than 5 seconds!



Emergency exit!

- Always keep the emergency exit clear.
- Follow the arrows if necessary.
- Doors must be pushed open in escape direction.

2.7 Safety Devices

The supplied cryostat of the magnet system is equipped with the following safety devices:

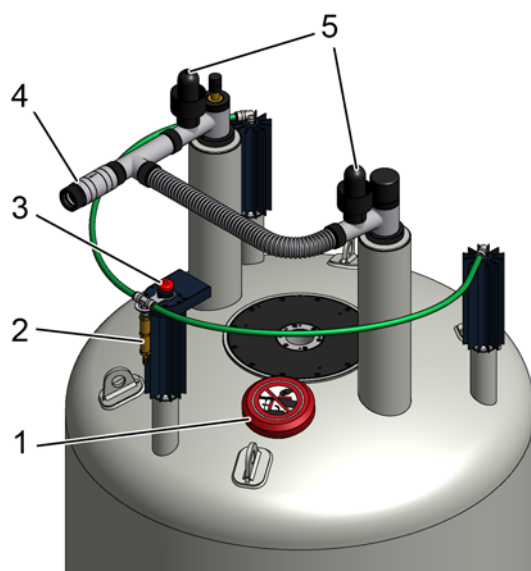

- 1 Drop-off plate
- 2 One-way valve of the nitrogen vessel
- 3 Safety valve of the nitrogen vessel
- 4 One-way valve of the helium vessel
- 5 Quench valves

Figure 2.1: Safety Devices of the Cryostat with 2 Helium Turrets

Quench Valve

The quench valves (5) are the safety devices of the helium vessel. They open with a defined pressure. In case of an accidental overpressure in the helium vessel the quench valves will release the pressure smoothly.

Safety Valve

The safety valve (3) is the safety device of the nitrogen vessel. It opens with a defined pressure. In case of an accidental overpressure in the nitrogen vessel the safety valve will release the pressure smoothly.

Drop-off Plate

The drop-off plate (1) is a safety device of the RT vessel. If the vacuum breaks, the drop-off plate will open. In case of an accidental overpressure in the RT vessel the drop-off plate will release the pressure smoothly.

One-way Valves

The one-way valves of the nitrogen flow system (2) and of the helium flow system (4) keep air and moisture from entering the nitrogen vessel or the helium vessel in case of an accidental underpressure inside the vessels.

2.8 Behavior in Danger and Emergency Situations

Preparations

- Keep the emergency exits free at all times.
- Prepare and maintain an up-to-date list of emergency telephone numbers in the magnet system area.

In Case of Emergency

- Leave the danger zone immediately.
- Check for sufficient ventilation in the room before entering, especially if people are showing symptoms of suffocation.
- Rescue persons from the danger zone.
- Provide medical attention for people with symptoms of suffocation.
- Start first aid immediately.
- Call the responsible contact.
- Call for medical assistance.
- Call the fire department.

First Aid for Cold Burns

- Help the injured persons to lie down comfortably in a warm room.
- Loosen all clothing which could prevent blood circulation in the injured area.
- Pour large quantities of warm water over the affected parts.
- Cover the wound with dry and sterile gauze.
- In case of contact of liquid cryogenic agents with the eyes rinse thoroughly with clean water.
- Call for medical assistance.

2.9 Fire Department Notification

- Inform the fire department about the technical risks of a magnet system, like danger due to ferromagnetic rescue equipment near the magnet system.
- Laboratory windows which are accessible during an emergency should be clearly identified with warning signs, visible from the outside.
- Inform the fire department about the characteristics of a quench to prevent confusion with smoke.
- Never pour water over the magnet system during a quench!

3 Transportation

3.1 Safety

The transportation is carried out by Bruker Service or approved persons. However, it may happen that other persons have to receive the delivery of the shipping boxes. In this case it is essential to obey the instructions in this chapter and to inform these persons before.



⚠ WARNING

Heavy Weights (see [page 20](#))



⚠ CAUTION

Transportation (see [page 21](#))

3.2 Packaging



The cryostat is supplied in a wooden box on a pallet. It is secured inside with straps against tilting and moving.

Accessories such as the flow systems, level sensors and bore tubes are in the side compartment of the box.

The Magnet Stand is supplied in a wooden box on a pallet.

Figure 3.1: Packaging (without surrounding panels)

3.2.1 Disposal

Keep the original boxes for future transportation.

If no further transportation is planned, dispose of the boxes according to environmentally friendly regulations.

3.3 Transport Inspection

Investigate the delivery with regard to visible damage and completeness of delivery.

Transport control systems

The shipping and handling monitors (“Shock Watch“, “Tilt Watch“) on the boxes show if the boxes were kicked or tilted during transportation.

Checks

Shock Watch: Follow instructions on the label.

Tilt Watch: Follow instructions on the label.

In case of damage

- Accept delivery with reservation.
- Make a documentation of all observable damage and add it to the transportation documents.
- Start complaint process.
- Contact Bruker Service before installation.

The claim for damage expires after the fixed period.



Thus:

Report damages to Bruker Service immediately after detection of damage. For contact information [see page 7](#) of this document.

3.4 Transportation by Fork Lift / Pallet Jack

A fork lift is recommended for transporting the boxes to the installation site.

Approved Persons: Approved forklift / pallet jack operator

Precondition: The fork lift / pallet jack must be approved for the transportation weight (refer to the supplied Sales Information).

Transport



Figure 3.2: Transportation by Forklift - front side

1. Check the route of transport for the minimal height and width.
2. Check sufficient floor capacity on the route of transport. In case of doubt ask a stress analyst.
3. Check sufficient carrying capacity while using an elevator.
4. Position the forks between the bars of the box as shown in the figure. Make sure the side towards the operator is the one with the labels on it.



Figure 3.3: Transportation by Forklift - rear side

5. Make sure the forks of the fork lift are longer than the box and projects out of the back of the box as shown in the figure.
6. Now lift the fork and move the box to the site.

3.5 Transportation with a Crane

A crane is recommended for lifting the cryostat out of the box.

Approved Persons: Approved crane operator

Precondition: The crane must be approved for the transportation weight (see “Dimensions for Transportation” on page 125.).

Attachment Points



1. Exclusively use the marked eyelets as attachment points for the lifting equipment.
2. Use **all** eyelets for the lifting equipment.

Figure 3.4: Attachment Points for Lifting Equipment

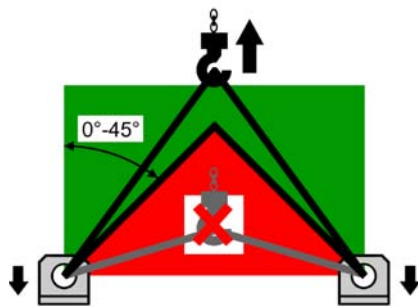

3. Follow the instructions on the label on top of the cryostat. This label gives important information about correct attachment and transportation.
4. Check for correct fastening of the lifting equipment before lifting the cryostat.
5. Make sure that any movement of the crane is as slowly as possible to avoid any damage due to acceleration.
6. Check for correct leveling of the cryostat while hanging on the crane.

Figure 3.5: Instruction Label for Lifting Equipment

3.6 Storing

If it is necessary to store the cryostat and accessories before installation obey the following instructions:

- Store the boxes in a closed, dry and dust-free room.
- Store the boxes upright.
- Do not tilt the boxes.
- Do not unpack the supplied boxes.
- Prevent mechanical vibrations to the boxes.
- Storage temperature: 5 - 40 °C.
- Storage humidity: less than 50% @ 23 °C.

3.7 Disposal

For disposal after the life cycle please contact Bruker Service for further information. For contact information [see page 7](#) of this document.

4 Assembly

4.1 Safety

Approved Persons: Bruker Service only

5 Operation

5.1 Safety

Approved Persons

Bruker Service, Approved Customer Personnel

WARNING



Magnetic Field (see [page 16](#))

Cryogenic Agents (see [page 17](#))

Electricity (see [page 17](#))

Gas under Pressure (see [page 18](#))

5.2 Set into Operation



Figure 5.1: Start the Magnet Stand

If the magnet system is equipped with a magnet stand with pneumatic isolators:

Set the magnet stand into operation by switching the pneumatic controller to UP position.



Figure 5.2: Stop the Magnet Stand

For any work at the magnet system like maintenance or refill of cryogenic agents stop the magnet stand by switching the pneumatic controller to DOWN position.

6 Troubleshooting

Troubleshooting must be performed only with approved qualification.

In case of doubts or problems not specified in the following list contact Bruker Service immediately. For contact information [see page 7](#) of this manual.

6.1 Safety

Only approved persons should perform the troubleshooting tasks. They are outlined in this chapter:

- Bruker Service
- Approved Customer Personnel

WARNING



Magnetic Fields (see [page 16](#))

Cryogenic Agents (see [page 17](#))

Electricity (see [page 17](#))

Gas under Pressure (see [page 18](#))

Spontaneous Ignition and Explosion (see [page 19](#))

Personal protective equipment

- Protective goggles
- Protective gloves
- Protective clothes
- Safety shoes

6.2 Problem

6.2.1 During Transportation

| Indicator | Possible reason | Solution | Performed by |
|-------------------------------------|--------------------------|--|-----------------------------|
| Tilt Watch / Shock Watch activated. | Careless transportation. | <ol style="list-style-type: none"> 1. Accept delivery with reservation. 2. Remark the extent of damage in the transportation documents. 3. Start complaint process. | Approved Customer Personnel |
| Visible damage. | Careless transportation. | <ol style="list-style-type: none"> 1. Accept delivery with reservation. 2. Remark the extent of damage in the transportation documents. 3. Start complaint process. | Approved Customer Personnel |

6.2.2 During Assembly

| Indicator | Possible reason | Solution | Performed by |
|---|---|--|----------------|
| Ceiling height too low for assembly on magnet stand. | Site does not meet the required conditions. | Choose another site that meets the required conditions. | Bruker Service |
| Ceiling height too low for inserting the Helium Level Sensor. | Site does not meet the required conditions. | Insert the Helium Level Sensor before mounting the magnet stand. | Bruker Service |
| Helium bore and radiation shield are not centered. | Alignment is not correct. | Check fitting of the alignment rods. | Bruker Service |
| | Alignment rod is loose or broken. | Replace alignment rod ^a . | Bruker Service |
| | Reduction flange is not centered. | Check the position of the reduction flange. | Bruker Service |

Table continued

| Indicator | Possible reason | Solution | Performed by |
|--|--|--|----------------|
| Vacuum valve is touching the magnet stand. | Vacuum valve mounted incorrectly. | Reposition the vacuum valve. | Bruker Service |
| Vacuum in RT vessel does not reach 5×10^{-5} mbar within 48 hours. | O-rings may be damaged. | Check and clean O-rings and slots. If necessary, replace the O-rings for <ul style="list-style-type: none"> • the vacuum valve • the drop-off plate • the reduction and sealing flanges • the bottom plate ^a. | Bruker Service |
| | Defective pumping unit or pumping line. | Check pumping unit and pumping line: A vacuum of at least 10^{-6} mbar must be reached while the sealing plug is closed. Replace if necessary. | Bruker Service |
| | Room temperature bore has scratches or dust on the sealing surfaces. | Check sealing surfaces on the RT bore: No scratches and no dust should be visible. | Bruker Service |
| | Moisture in the RT vessel. | Use dry N ₂ gas to pump and flush the RT vessel. | Bruker Service |
| Super insulation is touching the RT vessel or the RT bore or the radiation shield. | Super insulation was not attached correctly during assembly. | Attach the super insulation on the outer radiation shield using polyester tape ^a . Carefully prevent any contact of the vessels or the RT bore in the cryostat. | Bruker Service |

a. This work requires to remove the bottom plate. Before removing the bottom plate check that the suspension tubes of the helium vessel are not broken. Install the safety device for fall protection (not supplied). Contact Bruker Service for further information.

6.2.3 During Cooling Procedure

| Indicator | Possible reason | Solution | Performed by |
|---|---|--|----------------|
| Cooling with liquid nitrogen is too slow. | Empty transportation dewar. | Refill or replace transportation dewar. | Bruker Service |
| | Transfer pressure too low. | Increase transfer pressure slightly (max. pressure 0.3 bar). | Bruker Service |
| | Transportation dewar is leaky; no transfer pressure can be applied. | Check transportation dewar and replace if necessary. | Bruker Service |
| Precooling with liquid nitrogen occurs too quickly. | Transfer pressure too high. | Stop cooling. Adjust correct transfer pressure. | Bruker Service |
| Vacuum in RT vessel does not reach 5×10^{-5} mbar within 48 hours. | O-rings are leaky. | Check and clean O-rings and slots. If necessary, replace the O-rings for <ul style="list-style-type: none"> • the vacuum valve • the drop-off plate • the reduction and sealing flanges • the bottom plate ^a. | Bruker Service |
| | O-rings are frozen due to contact with liquid nitrogen. | <ol style="list-style-type: none"> 1. Stop cooling. 2. Warm up O-ring with warm air. 3. Wait until the vacuum is recovered. 4. Prevent liquid nitrogen from splashing on O-rings. | Bruker Service |
| | Pumping unit or pumping line is defective. | Check pumping unit and pumping line: A vacuum of at least 10^{-6} mbar must be reached while the sealing plug is closed. Replace if necessary. | Bruker Service |

a. See note on previous page.

Table continued

| Indicator | Possible reason | Solution | Performed by |
|---|--|--|----------------|
| RT vessel becomes cold and wet. | Vacuum is broken or less than 10^{-3} mbar. | <ul style="list-style-type: none"> • Keep the pumping unit connected until filling with liquid helium is finished. • Continue as in problem <i>Vacuum in RT vessel does not reach 10^{-6} mbar.</i> | Bruker Service |
| | Cold leak after transportation. | <ol style="list-style-type: none"> 1. Stop cooling. 2. Warm the cryostat. | Bruker Service |
| Cold spot in the RT bore. | Alignment not correct. | <ol style="list-style-type: none"> 1. Stop cooling. 2. Warm the cryostat. 3. Align the vessels. | Bruker Service |
| The helium flow system becomes very cold and icy during flushing with helium gas. | Liquid nitrogen remains in the helium vessel, boiling off strongly during flushing. | <ol style="list-style-type: none"> 1. Stop flushing. 2. Carefully remove all liquid nitrogen using the precooling tube. 3. Use the dipstick to check that the helium vessel is empty (no liquid nitrogen or frozen nitrogen). | Bruker Service |
| After some intervals of flushing it is not possible to reach a vacuum in the range of 1 mbar. | The globes in the quench valves are not fitting correctly in the O-rings and thus the quench valves are leaky. | <ol style="list-style-type: none"> 1. Stop pumping. 2. Remove frozen air and frozen moisture using warm helium gas. 3. Apply a small amount of grease to the O-rings and check the position of the globes. 4. Use the dipstick to check that the helium vessel is empty (no liquid nitrogen or frozen nitrogen). | Bruker Service |
| | Liquid nitrogen remains in the helium vessel, boiling off strongly during flushing. | <ol style="list-style-type: none"> 1. Stop pumping. 2. Use the precooling tube to remove all liquid nitrogen. 3. Use the dipstick to check that the helium vessel is empty (no liquid nitrogen or frozen nitrogen). | Bruker Service |

Table continued

| Indicator | Possible reason | Solution | Performed by |
|---|---|---|----------------|
| Nitrogen ice in the helium vessel. | Times between pumping and flushing were too long. Nitrogen boiled off during pumping and remaining nitrogen got frozen during flushing. | <ol style="list-style-type: none"> 1. Warm the magnet coil with warm helium gas by using the precooling tube until the whole coil is at 90 K or above. 2. Repeat pumping and flushing. 3. Use the dipstick to check that the helium vessel is empty (no liquid nitrogen or frozen nitrogen). | Bruker Service |
| Transfer of liquid helium does not start. | The transportation dewar is empty. | Refill or replace transportation dewar. | Bruker Service |
| | The transfer pressure in the transportation dewar is too low. | Increase the transfer pressure. | Bruker Service |
| | The transportation dewar is leaky, no transfer pressure is built up. | Check the transportation dewar for leakage. Re-tighten all connections. | Bruker Service |
| | The siphon or the helium transfer line are blocked with ice. | Check the siphon and helium transfer line for blockages. Remove ice with warm helium gas. | Bruker Service |

Table continued

| Indicator | Possible reason | Solution | Performed by |
|---|--|---|----------------|
| The cooling of the magnet coil does not continue although helium is transferred. | The helium transfer line is defective. | Check the helium transfer line for ice. If there are cold spots visible, replace the helium transfer line. | Bruker Service |
| | The extension piece is not mounted on the helium transfer line. | Mount the extension piece on the helium transfer line. Check the helium transfer line is completely inserted into the siphon. | Bruker Service |
| The zero reading of the Helium Level Sensor can not be adjusted at the beginning of cooling with liquid helium. | The Helium Level Sensor is not connected correctly with the connector in the helium flow system. | Check the connection in the helium fill-in turret between Helium Level Sensor and connector. | Bruker Service |
| | The Helium Level Sensor is defective. | Check the Helium Level Sensor using the 0 % calibration plug. | Bruker Service |
| The helium level does not reach 100 % after cooling. | Empty transportation dewar, helium transfer stopped. | Refill or replace transportation dewar. | Bruker Service |
| | The Helium Level Sensor is disturbed by the transfer line's extension piece. | <ol style="list-style-type: none"> 1. Stop the liquid helium transfer. 2. Remove the transfer line. 3. Wait for a few minutes. 4. Measure the helium level to check the Helium Level sensor is working correctly. | Bruker Service |
| After cooling the rate of helium boil off is higher than specified (up to 5 times). | Usual behavior. A few days are necessary for the radiation shields and the insulation to reach scheduled temperatures. | <p>Wait a few days and check helium boil off.</p> <p>The presence of the current lead in the current lead turret during energizing and shimming helps cooling the radiation shield due to higher helium flow.</p> | Bruker Service |

6.2.4 During Energizing and Shimming

| Indicator | Possible reason | Solution | Performed by |
|---|---|---|----------------|
| The current lead can not be inserted completely into the connector. | The connector is covered with ice (frozen moisture or nitrogen ice). | Carefully remove the ice with warm helium gas. Use the dipstick or the precooling tube as tubing for the warm helium gas to remove small ice spots. | Bruker Service |
| | The shorting plug was not removed. | Remove the shorting plug with the shorting plug tool. | Bruker Service |
| | The orientation of the current lead is not correct. | Carefully reposition the current lead until it can be inserted correctly into the connector. | Bruker Service |
| Main coil heater test fails. | Power supply defective. | Replace the power supply. | Bruker Service |
| | Connector or cables defective. | Clean connectors or replace cables, if necessary. | Bruker Service |
| Setting of sense voltage fails. | The main coil heater switch is "OFF". The main coil switch is not opened. | Switch the main coil heater to "ON" and check the main coil heater current to be adjusted correctly. | Bruker Service |
| | The main coil heater current is not correct. The main coil switch is not opened. | Adjust main coil heater current correctly. | Bruker Service |
| | The auxiliary shorting plug is inserted in the current lead turret by mistake and makes a short circuit across the main coil. | Remove the auxiliary shorting plug and insert it in the helium fill-in turret. | Bruker Service |

Table continued

| Indicator | Possible reason | Solution | Performed by |
|--|---|--|----------------|
| Current lead can not be removed. | The connector is covered with ice (frozen moisture or nitrogen ice). | Carefully remove the ice with warm helium gas over the helium flow system. Use the dipstick or the precooling tube as tubing for the warm helium gas to remove small ice spots from the connector. | Bruker Service |
| Shorting plug can not be removed. | The connector is covered with ice (frozen moisture or nitrogen ice). | Carefully remove the ice with warm helium gas. Use the dipstick or the precooling tube as tubing for the warm helium gas to remove small ice spots from the connector. | Bruker Service |
| The magnet system quenches. | Loss of superconductivity. | see "After a Quench" on page 52. | Bruker Service |
| | The helium level was too low for energizing, cycling, shimming, de-energizing or sweeping. | see "After a Quench" on page 52. | Bruker Service |
| | The power supply is defective. The main current is oscillating. | Replace the power supply. | Bruker Service |
| The main coil switch can not be closed on field. | The helium level is too low for energizing. The main coil switch is not covered with liquid helium. | Never try to energize the magnet with a helium level less than the "minimum level during energizing" in the helium vessel. | Bruker Service |
| | The power supply is defective. The main current is oscillating. | Replace the power supply. | Bruker Service |

Table continued

| Indicator | Possible reason | Solution | Performed by |
|---|--|--|----------------|
| Shim current can not be set correctly. | The control cable is not connected correctly to the current lead or to the power supply. | Connect the control cable correctly to the current lead and to the power supply. | Bruker Service |
| | The switch „Main Coil/OFF/Shim Coil“ is in the wrong position. | Change the switch position. | Bruker Service |
| Shims do not affect the NMR signal. | Shim heater current is not correct. The shim switches are not opened. | Set the shim heater current to the specified value (see “Energizing Assignment and Currents” on page 147). | Bruker Service |
| Magnet system does not reach specification. | Magnetic material inside RT bore tube. | Carefully clean the RT bore tube. | Bruker Service |
| | Large ferromagnetic parts near the magnet system. | <ol style="list-style-type: none"> As much as possible, keep all ferromagnetic parts away from the magnet system. Repeat shimming. | Bruker Service |

6.2.5 During Operation of the Magnet Stand

More information is available in the Magnet Stand manual.

| Indicator | Possible reason | Solution | Performed by |
|--|---|---|-----------------------------|
| The NMR spectrum shows massive disturbances. | Pneumatic controller is in DOWN position. | Switch pneumatic controller to UP position. | Approved Customer Personnel |
| | Magnet system is touching the floor via accessories or cables. | Identify and eliminate contact point. Arrange cables in loose S- or U-shapes. | Approved Customer Personnel |
| | | If the problem is still not solved, contact Bruker Service. | Approved Customer Personnel |
| | Magnet system is touching the magnet stand. | Check the level; adjust if necessary. | Approved Customer Personnel |
| | Piston of the isolator is not centered or is touching its casing. | Align magnet stand. | Bruker Service |
| | T-safety bracket is touching the pillar. | Align magnet stand. | Bruker Service |
| | Floor vibrations in vertical direction. | Replace elastomeric isolators with air damped isolators. | Bruker Service |
| | Floor vibrations in horizontal and vertical direction. | Replace air damped isolators with air piston isolators. | Bruker Service |

Table continued

| Indicator | Possible reason | Solution | Performed by |
|---|--|--|-----------------------------|
| The pneumatic isolator of the magnet stand does not reach the operating position. | Pneumatic controller in DOWN position. | Switch pneumatic controller to UP position. | Approved Customer Personnel |
| | The pressure of the gas supply is too low. | Check the pressure of the pneumatic supply. It must be in the range of 5 to 8 bar (70 to 112 psi). | Approved Customer Personnel |
| | | If the problem is still not solved, contact Bruker Service. | Approved Customer Personnel |
| | The magnet system is not level. | Stop the pneumatic isolators. Check the level of the cryostat. | Bruker Service |
| | Defective leveling valve. | Replace leveling valve or isolator. | Bruker Service |
| | Defective membrane of an isolator. | Replace leveling valve or isolator. | Bruker Service |
| The movement of the magnet stand is not smooth. | Piston is not centered or is touching its casing. | Align magnet stand. | Bruker Service |
| Audible loss of gas. | Defective membrane or defective leveling valve of an isolator. | Replace leveling valve or isolator. | Bruker Service |
| | Hose connector is defective or loose. | Insert hoses correctly and tighten screws. | Bruker Service |
| The movement of the magnet stand is too fast. | Incorrect adjustment of the flow control valve. | Close fully the flow control valve; then open ½ turn. | Bruker Service |

6.2.6 During Standard Operation

| Indicator | Possible reason | Solution | Performed by |
|--|--|---|-----------------------------|
| The helium boil off decreases to zero. | The atmospheric pressure is increasing. | Usual behavior. Check the helium boil off daily. | Approved Customer Personnel |
| | The helium flow system is covered with ice. | Contact Bruker Service immediately! Do not try to remove ice from the helium flow system! | Approved Customer Personnel |
| | ⚠ WARNING: Cryogenic Agents Quench | | |
| | The helium flow system or the suspension tubes are blocked with ice. | Flush in warm helium gas through an applicable tube. Do not insert the tube more than 600 mm from the top of the helium turrets. | Bruker Service |
| The helium boil off is too high. | The Helium Level Sensor is in service mode or has been used too often. | Switch off Helium Level Sensor. Reduce frequency of helium level measurement (during measuring of the helium level an amount of helium boils off due to the heat input of the Helium Level Sensor). | Approved Customer Personnel |
| | The atmospheric pressure is decreasing. | Usual behavior. Check the helium boil off daily. | Approved Customer Personnel |
| | | If it continues, contact Bruker Service. | Approved Customer Personnel |
| | Vacuum reduced. | Rebuild vacuum, see "Rebuilding Vacuum" in the service manual. | Bruker Service |
| The radiation baffles are not inserted in the current lead turret. | Insert the radiation baffles into the current lead turret. | Bruker Service | |

Table continued

| Indicator | Possible reason | Solution | Performed by |
|--|---------------------------------------|---|-----------------------------|
| Quench. | Loss of superconductivity. | see "After a Quench" on page 52. Contact Bruker Service immediately! | Approved Customer Personnel |
| Cold spots in the RT bore. | Alignment of the vessels not correct. | Contact Bruker Service. | Approved Customer Personnel |
| RT vessel is wet and cold. | Vacuum reduced. | Contact Bruker Service immediately! | Approved Customer Personnel |
| Helium level warning out of MICS is false. | Helium Level Sensor defective. | Contact Bruker Service immediately! | Approved Customer Personnel |
| Helium level at constant level, no change during days. | Helium Level Sensor defective. | Contact Bruker Service immediately! | Approved Customer Personnel |
| | | ⚠ WARNING: Low Temperature | |
| Helium level warning out of MICS is false. | Helium Level Sensor defective. | Replace Helium Level Sensor (see chapter "Replacement of the Helium Level Sensor" in the service manual). | Bruker Service |
| Helium level at constant level, no change during days. | Helium Level Sensor defective. | Replace Helium Level Sensor (see chapter "Replacement of the Helium Level Sensor" in the service manual). | Bruker Service |

6.2.7 During De-energizing and Warming

| Indicator | Possible reason | Solution | Performed by |
|--|---|--|----------------|
| The magnet system quenches during de-energizing. | The helium level was too low for de-energizing. | Refill helium at least to the minimum allowed level (see page 72). | Bruker Service |
| | The Power Supply is defective. | Replace Power Supply. | Bruker Service |
| | The main current is oscillating. | Replace Power Supply. | Bruker Service |
| The shim current can not be set correctly. | The control cable is not connected correctly to the current lead and/or the Power Supply. | Connect the control cable to the current lead and to the Power Supply correctly. | Bruker Service |
| | The switch "Main Coil/OFF/Shim Coil" is not on the "Shim Coil" position. | Switch "Main Coil/OFF/Shim Coil" on the "Shim Coil" position. | Bruker Service |
| High helium flow after breaking vacuum. | Remaining cryogenic agents in the vessels. | Remove liquid cryogenic agents. | Bruker Service |
| Vacuum still remains after 12 hours. | Vacuum valve is closed. | Open the vacuum valve. Block it if necessary. | Bruker Service |
| RT vessel is wet and cold. | Cryostat is still cold. | Wait until RT vessel is dry and warm. Check PT100 temperature sensors. | Bruker Service |
| RT bore is wet and cold before disassembly. | Cryostat is still cold. | Wait one more day. Do not open a cryostat before the room temperature bore tube is warm and dry! | Bruker Service |

6.3 Troubleshooting Work

6.3.1 After a Quench



A quench is the very fast de-energizing of the magnet by loss of its superconductivity. The stored magnetic energy is converted into heat, which promotes rapid evaporation of large quantities of helium. If a quench occurs contact Bruker Service immediately.

Figure 6.1: Magnet system during a quench



⚠ WARNING

Cryogenic Agents (see [page 17](#))

Quench (see [page 18](#))

Quench while in persistent mode:

1. Wait until helium stops evaporating and the quench valves are closed.
2. Wait until there is no helium vapor visible anywhere to make sure there is sufficient oxygen in the room.
3. Switch off the alarm at the CMU.
4. Check that the globes in the quench valves are in the correct position.
5. Remove probe and shim system to prevent icing of the shim system.
6. Start the refill with liquid helium as soon as possible.



If the quench occurs unattended or helium transfer was not possible within one hour after the quench, it is recommended to warm up the system to 90 K. Refer to the supplied manual Refilling Procedure.

7. Contact Bruker Service immediately.

7 Maintenance

Maintenance must be performed only with approved qualification. In case of doubt contact Bruker Service. For contact information [see page 7](#) of this document.

7.1 Safety

Approved Persons

Bruker Service, Approved Customer Personnel



WARNING

Magnetic Field (see [page 16](#))

Cryogenic Agents (see [page 17](#))

Electricity (see [page 17](#))

Gas under Pressure (see [page 18](#))

Low Temperatures (see [page 19](#))

Spontaneous Ignition and Explosion (see [page 19](#))

Personal protective equipment

Protective goggles

Protective gloves

Safety shoes

7.2 Cleaning

- Clean the RT vessel of the magnet system and the magnet stand with a dry or slightly damp cloth.
- Only use water and neutral detergents.
- Do not use volatile cleaning solvents.

7.3 Maintenance Timetable

| Interval | Device | Work | Performed by |
|----------|----------|---|-----------------------------|
| daily | Cryostat | Check the helium flow. | Approved Customer Personnel |
| daily | Cryostat | Check the nitrogen flow. | Approved Customer Personnel |
| weekly | Cryostat | <ul style="list-style-type: none"> Check the helium level. Refill liquid helium if necessary according to the supplied Refilling Procedure manual following the warnings and instructions given there. Record the filling session. A record of changes in the estimated consumption may be used for identification of problems. In this case contact Bruker Service. | Approved Customer Personnel |
| weekly | Cryostat | <ul style="list-style-type: none"> Check the nitrogen level. Refill liquid nitrogen if necessary according to the supplied Refilling Procedure manual. Weekly refill of liquid nitrogen is recommended. Record the filling session. A record of changes in the estimated consumption may be used to identify problems. In this case contact Bruker Service. | Approved Customer Personnel |

Table 7.1: Maintenance Timetable

7.4 Maintenance-free Components

| Interval | Device | Work | Performed by |
|----------|---------------|---|-----------------------------|
| --- | Quench valves | <p>The quench valves are maintenance-free.</p> <ul style="list-style-type: none"> However, in the event of a quench check the correct position of the globes in the quench valves. | Approved Customer Personnel |

Table 7.2: Maintenance-free Components of the Magnet System

8 Disassembly

8.1 Safety

Approved Persons: Bruker Service only

9 Technical Data MS 400'54 Ascend

9.1 Environmental Conditions

| | Value | Unit |
|---|---------|------|
| Minimum surrounding temperature | 7 | °C |
| Maximum surrounding temperature | 38 | °C |
| Maximum relative humidity up to 31 °C | 80 | % |
| Maximum relative humidity between 31 °C and 40 °C linearly decreasing | 80 – 50 | % |

Table 9.1: Environmental conditions

9.2 Identification Plate

The identification plate is on the right rear side attached to the bottom plate of the cryostat.

Contents of the identification plate:

- Address of the Manufacturer
- Magnet System Identifier
- Type
- Magnet Identifier
- Serial Number
- Year of Construction
- Cryostat Identifier
- Specification Helium Vessel
- Specification Nitrogen Vessel
- Specification Vacuum Chamber
- Weight (empty and completely filled) including magnet stand

9.3 Dimensions

9.3.1 Weights

| | Value | Unit |
|--|-------|------|
| Weight magnet system (empty, without magnet stand) | 358 | kg |
| Weight magnet system (completely filled, without magnet stand) | 457 | kg |
| Operational weight (completely filled, with magnet stand) | 569 | kg |
| Weight magnet stand | 112 | kg |
| Weight magnet stand (ready for transportation, including box) | 169 | kg |
| Weight magnet system (empty, ready for transportation, including box and transportation locks) | 488 | kg |

Table 9.2: Weight of the magnet system

9.3.2 Dimensions for Transportation

| | L x D x H | Unit |
|------------------------|----------------|-----------------|
| Box with magnet system | 114 x 93 x 199 | cm ³ |
| Box with magnet stand | 80 x 76 x 122 | cm ³ |

Table 9.3: Dimensions for transportation of the magnet system

9.3.3 Dimensions Cryostat

Front View

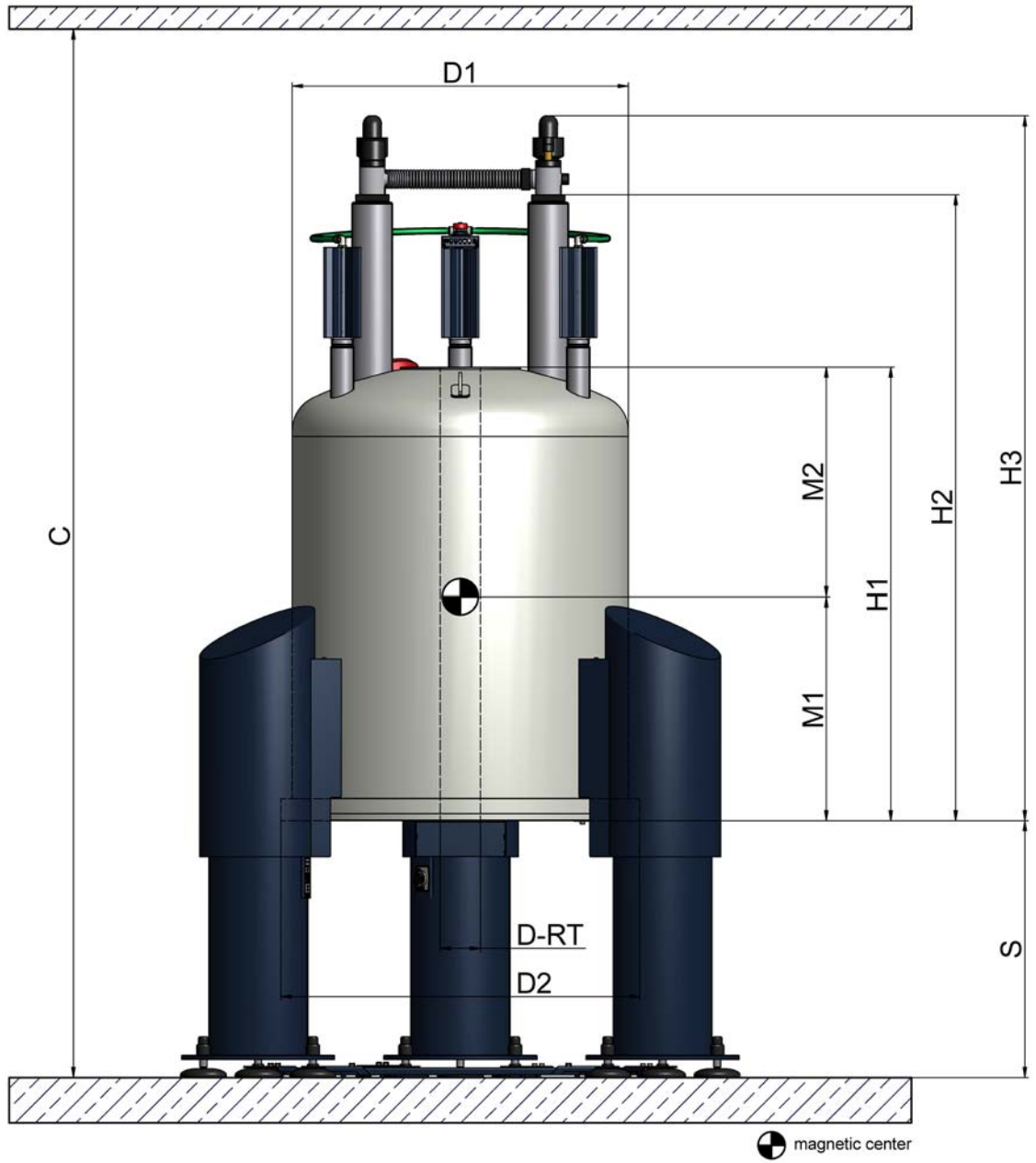

Figure 9.1: Dimensions of the cryostat (front view)

| Dimensions Cryostat | Value | Unit |
|---|-------|------|
| C Operational Ceiling Height | 2520 | mm |
| D-RT Diameter RT Bore Tube | 54 | mm |
| D1 Diameter RT vessel | 745 | mm |
| D2 Diameter Bottom Plate | 795 | mm |
| H1 Height Cryostat (bottom plate to top flange) | 1005 | mm |
| H2 Height Cryostat (minimum height for transportation) | 1391 | mm |
| H3 Height Cryostat (bottom plate to flow system) | 1564 | mm |
| S Height Magnet Stand (floor to bottom plate) | 570 | mm |
| M1 Distance magnetic center to bottom flange (calculated) Refer to Table 9.17 on page 75 for the measured distance of the magnetic center to bottom flange (MCB). | 317 | mm |
| M2 Distance magnetic center to top flange (calculated) Refer to Table 9.17 on page 75 for the measured distance of the magnetic center to top flange (MCT). | 688 | mm |

Table 9.4: Dimensions of the cryostat – front view

Top View

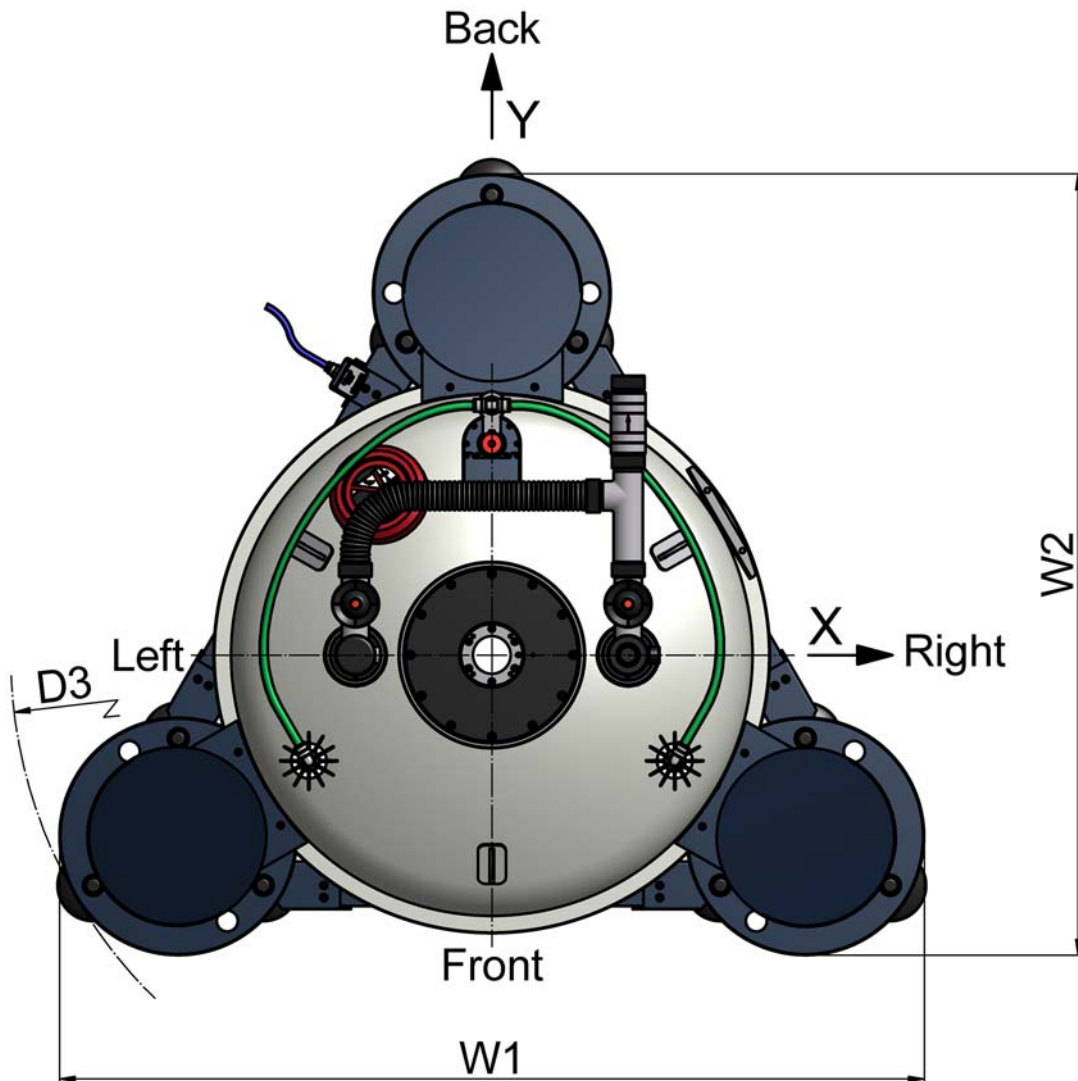

Figure 9.2: Dimensions of the cryostat (top view)

| Cryostat Dimensions | Value | Unit |
|---------------------|-------|------|
| W1 | 1236 | mm |
| W2 | 1116 | mm |
| D3 * | 1375 | mm |

Table 9.5: Dimensions of the cryostat – top view

* Keep at least an additional free space of 1.5 m around the magnet system for service.

9.4 Safety Valves

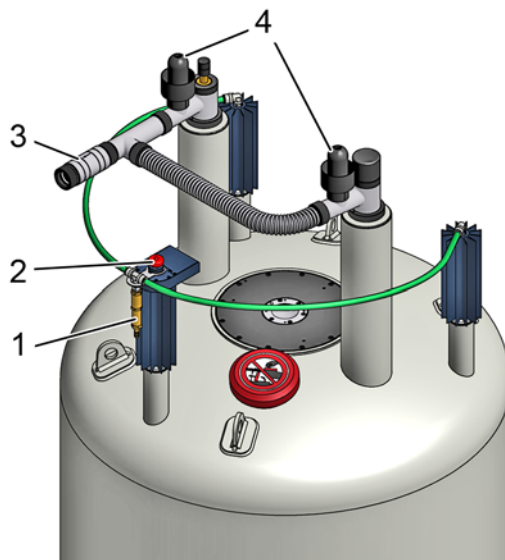

- 1 One-way valve of the nitrogen vessel
- 2 Safety valve of the nitrogen vessel
- 3 One-way valve of the helium vessel
- 4 Quench valve

Figure 9.3: Safety valves of the cryostat

| Opening pressure | mbar | psi |
|--------------------------------------|------|------|
| One-way valve of the nitrogen vessel | 10 | 0.15 |
| Safety valve of the nitrogen vessel | 138 | 2 |
| One-way valve of the helium vessel | 15 | 0.21 |
| Quench valve | 180 | 2.6 |

Table 9.6: Opening pressure of the safety valves of the magnet system

9.5 Nitrogen Level Sensor

The Nitrogen Level Sensor is inserted in the recommended nitrogen turret. 5 lights display the nitrogen level (see Figure 9.4:).

| Nitrogen Level Sensor | Material No. | Value | Unit |
|-----------------------|--------------|-----------------|------|
| Level Sensor Type | Z122394 | 12/926/660 D315 | |
| Diameter | | 12 | mm |
| Overall length | | 926 | mm |
| Active length | | 660 | mm |

Table 9.7: Nitrogen Level Sensor

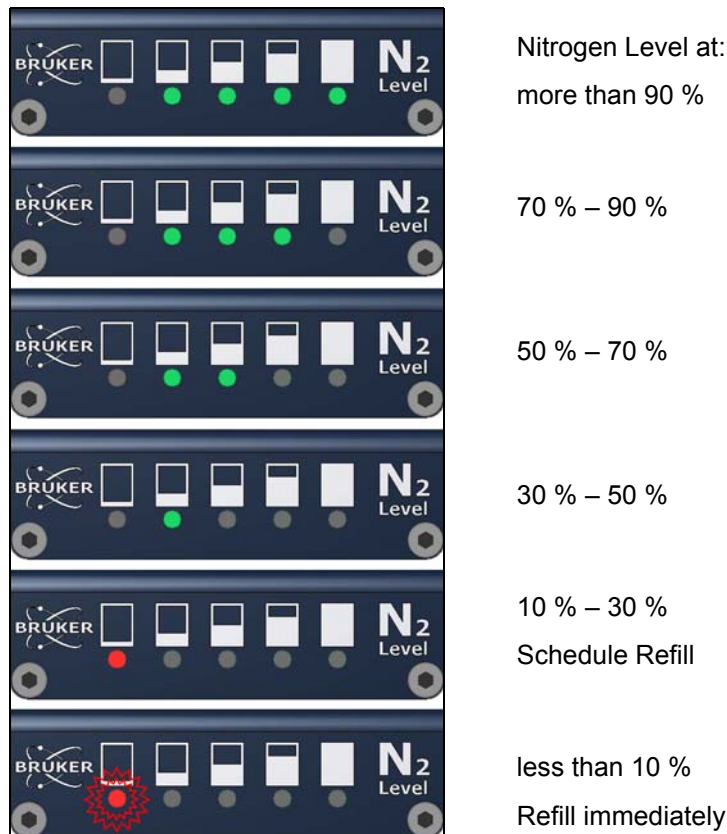

Figure 9.4: Nitrogen Level Sensor

9.6 Helium Level Sensor

The Helium Level Sensor is inserted in the helium fill-in turret.

| Helium Level Sensor | Material No. | Value | Unit |
|---|-----------------|----------|----------|
| Level Sensor Type | Z58114 | 1300/690 | |
| Overall length | | 1300 | mm |
| Active length | | 690 | mm |
| Calibration 0 %, Calibration resistor | Z28630 blue | 140 | Ω |
| Calibration 100 %, Calibration resistor | Z28628 black | 15 | Ω |

Table 9.8: Helium Level Sensor

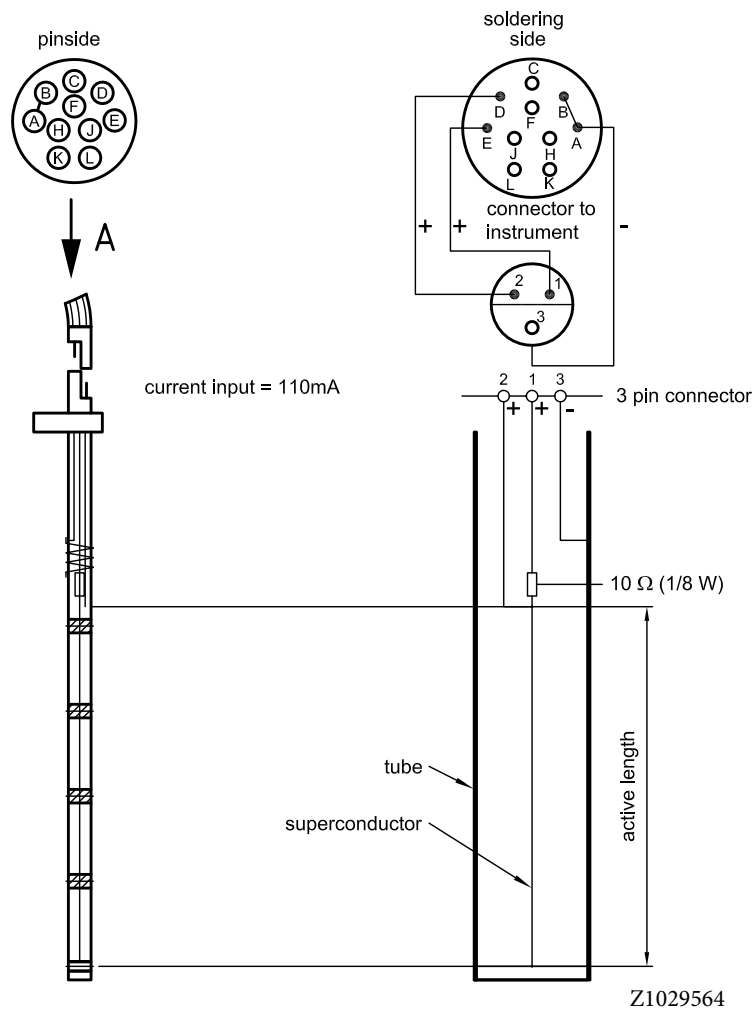

Figure 9.5: Helium Level Sensor

9.7 Temperature Sensors

The temperature sensors (PT 100 and IBT) are used to monitor the temperature of the magnet during cooling down and warming up the magnet system.

PT 100 Sensor



Measure the resistance with a maximum current of 1 mA.

| | Temperature | Unit | Resistance | Unit |
|------------------|-------------|------|------------|------|
| Room Temperature | 293 | K | 107.8 | Ω |
| | 273 | K | 100.0 | Ω |
| | 250 | K | 91.0 | Ω |
| | 200 | K | 71.1 | Ω |
| | 150 | K | 50.9 | Ω |
| | 100 | K | 30.0 | Ω |
| Liquid Nitrogen | 77 | K | 20.1 | Ω |

Table 9.9: Characteristic Values of PT 100 Sensor

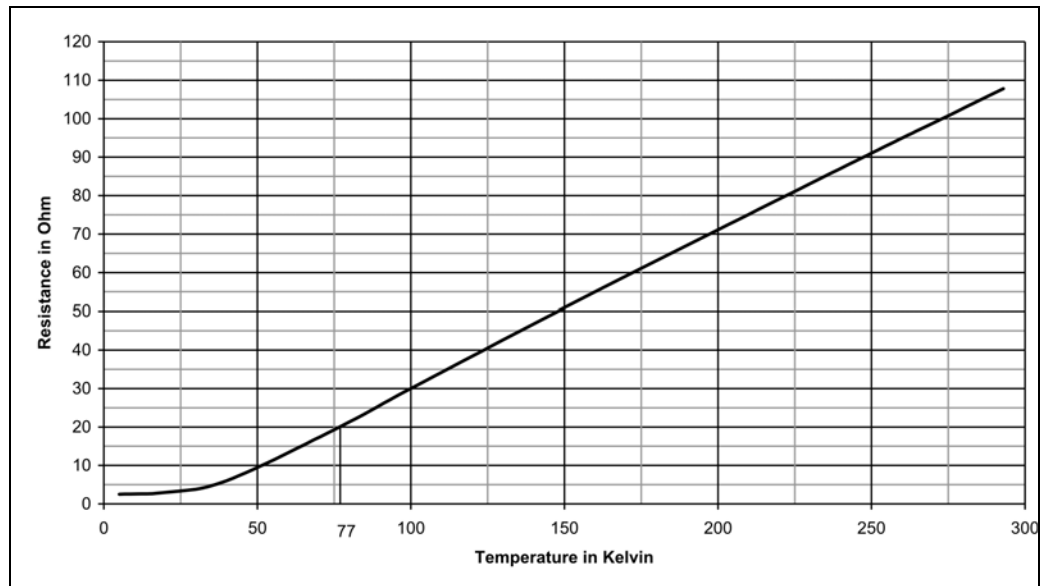

Figure 9.6: Characteristic Curve of PT 100 Sensor

IBT Carbon Resistor



Measure the resistance with a maximum current of 0.1 mA.

| | Temperature | Unit | Resistance | Unit |
|------------------|-------------|------|------------|----------|
| Room Temperature | 300 | K | 220 | Ω |
| Liquid Nitrogen | 77 | K | 265 | Ω |
| | 40 | K | 300 | Ω |
| | 20 | K | 350 | Ω |
| | 10 | K | 420 | Ω |
| | 8 | K | 450 | Ω |
| | 6 | K | 500 | Ω |
| | 5 | K | 540 | Ω |
| Liquid Helium | 4.2 | K | 575 | Ω |

Table 9.10: Characteristic Values of IBT Carbon Sensor

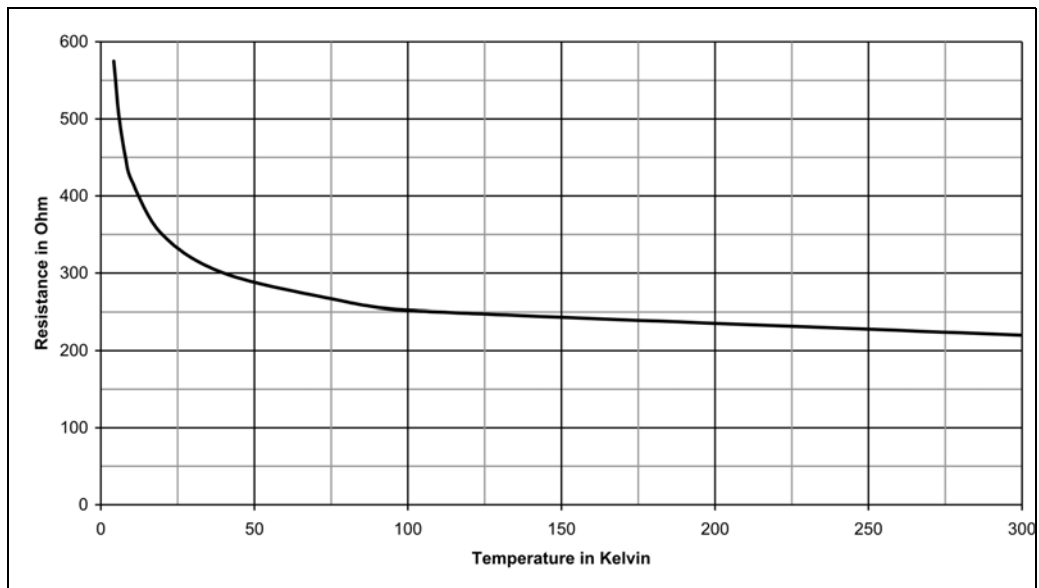

Figure 9.7: Characteristic Curve of IBT Carbon Sensor

This page will be replaced by specific technical data.

9.8 Technical Data Magnet

| Technical Data Magnet | Value | Unit |
|-----------------------|-------|-------|
| Proton frequency | 400 | MHz |
| Central field | 9.39 | T |
| Coil inductance | 30.39 | H |
| Magnetic energy | 164.5 | kJ |
| Maximum drift rate | 10 | ppb/h |
| | 4 | Hz/h |

Table 9.11: Specification of the Magnet

Operating Modes of the Magnet System:

Driven Mode

In the driven mode the current lead is mounted and the current flows through the power supply. The coils of the magnet can be energized and de-energized.

Persistent Mode

In the persistent mode the current flows exclusively within the magnet. The circuit has no connection to the outside. The magnetic field cannot be switched off.

9.9 Fringe Field Plot

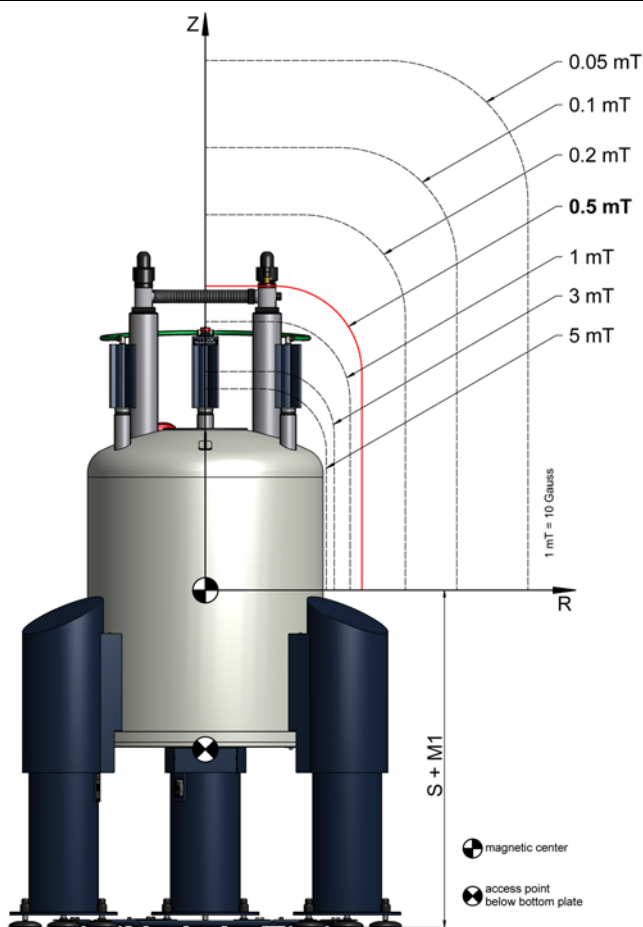

Figure 9.8: Fringe field plot of the magnet system at maximum field

| Fringe Field | Unit | R max | Unit | Z max | Unit |
|---|-----------|-------------|----------|-------------|----------|
| 200 | mT | 0.21 | m | 0.35 | m |
| 5.0 | mT | 0.37 | m | 0.64 | m |
| 3.0 | mT | 0.40 | m | 0.70 | m |
| 1.0 | mT | 0.46 | m | 0.87 | m |
| 0.5 (5 Gauss) | mT | 0.50 | m | 1.00 | m |
| 0.2 | mT | 0.62 | m | 1.23 | m |
| 0.1 | mT | 0.78 | m | 1.46 | m |
| 0.05 | mT | 1.00 | m | 1.75 | m |
| max. magnetic field B0 at access point | | | | 275.1 | mT |
| max. field gradient dB/dz at access point | | | | 5.35 | T/m |

Table 9.12: Fringe field data of the magnet system at maximum field

This page will be replaced by specific technical data.

9.10 Filling Volume, Evaporation Rate and Hold Time

Cryogenic Consumption

The consumption of liquid cryogenic agents during installation consists of consumption for cooling down the cryostat, for energizing, cryo shimming and quench reserve.

| Cryogenic Agents Consumption | Value | Unit |
|--|-------|------|
| Nitrogen | 400 | l |
| Helium (needed for cool down) | 200 | l |
| Helium (needed for energizing, cryo shimming and quench reserve) | 300 | l |

Table 9.13: Cryogenic Agents Consumption during Installation

| Cryogenic Agents | Value | Unit |
|---|-------|------|
| Nitrogen vessel total volume | 106 | l |
| Nitrogen refill volume | 85 | l |
| Nitrogen evaporation rate | 220 | ml/h |
| Nitrogen hold time ¹ | 16 | days |
| Helium vessel total volume | 106 | l |
| Helium refill volume | 94 | l |
| Helium evaporation rate | 13 | ml/h |
| Helium hold time ¹ | 300 | days |
| Helium refilling volume after quench (cool down and refill) | 100 | l |

Table 9.14: Cryogenic Agents

¹ Maximum time interval between two fillings

9.11 Nitrogen Level Graph

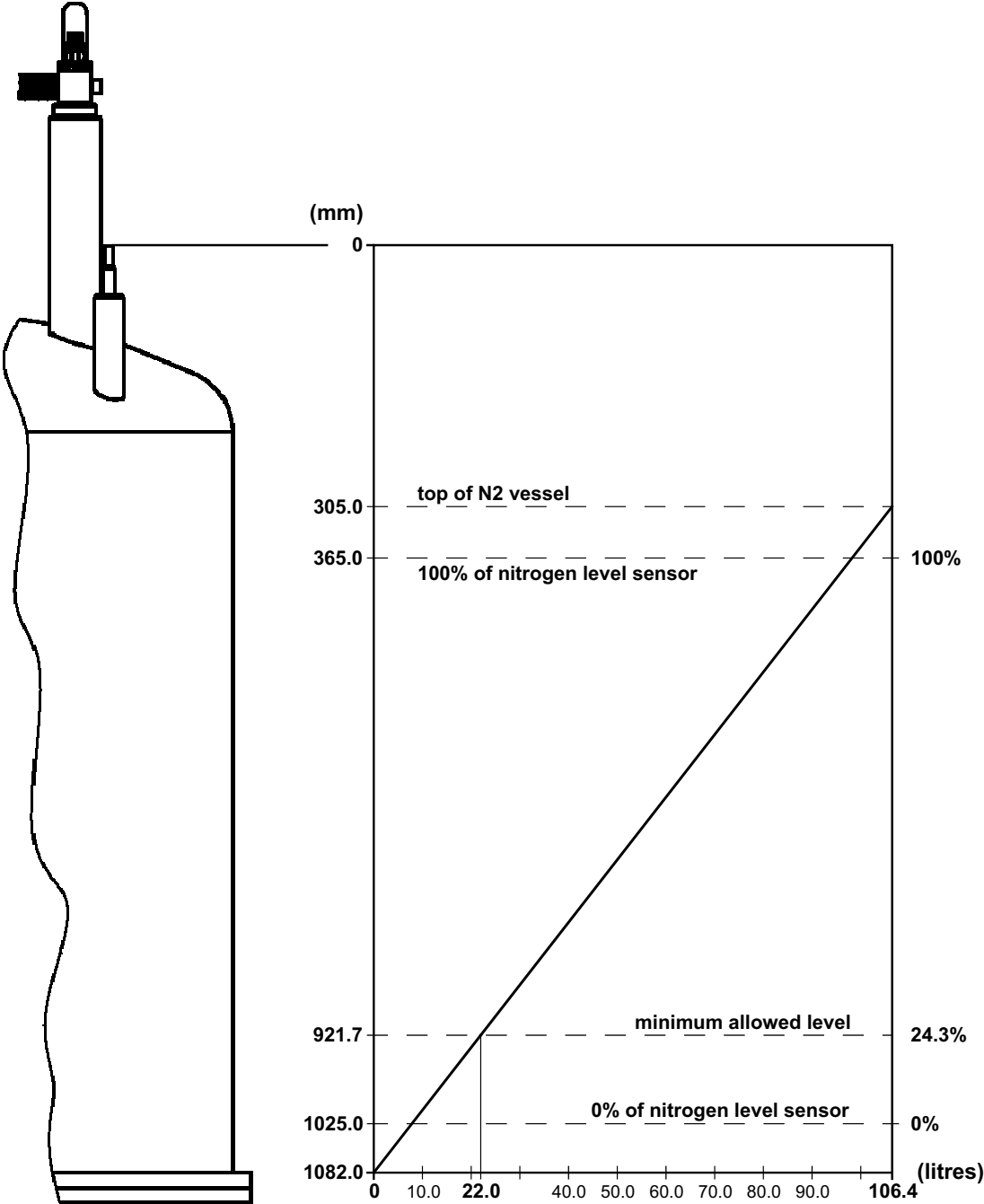

Figure 9.9: Nitrogen Level Graph

This page will be replaced by specific technical data.

9.12 Helium Level Graph

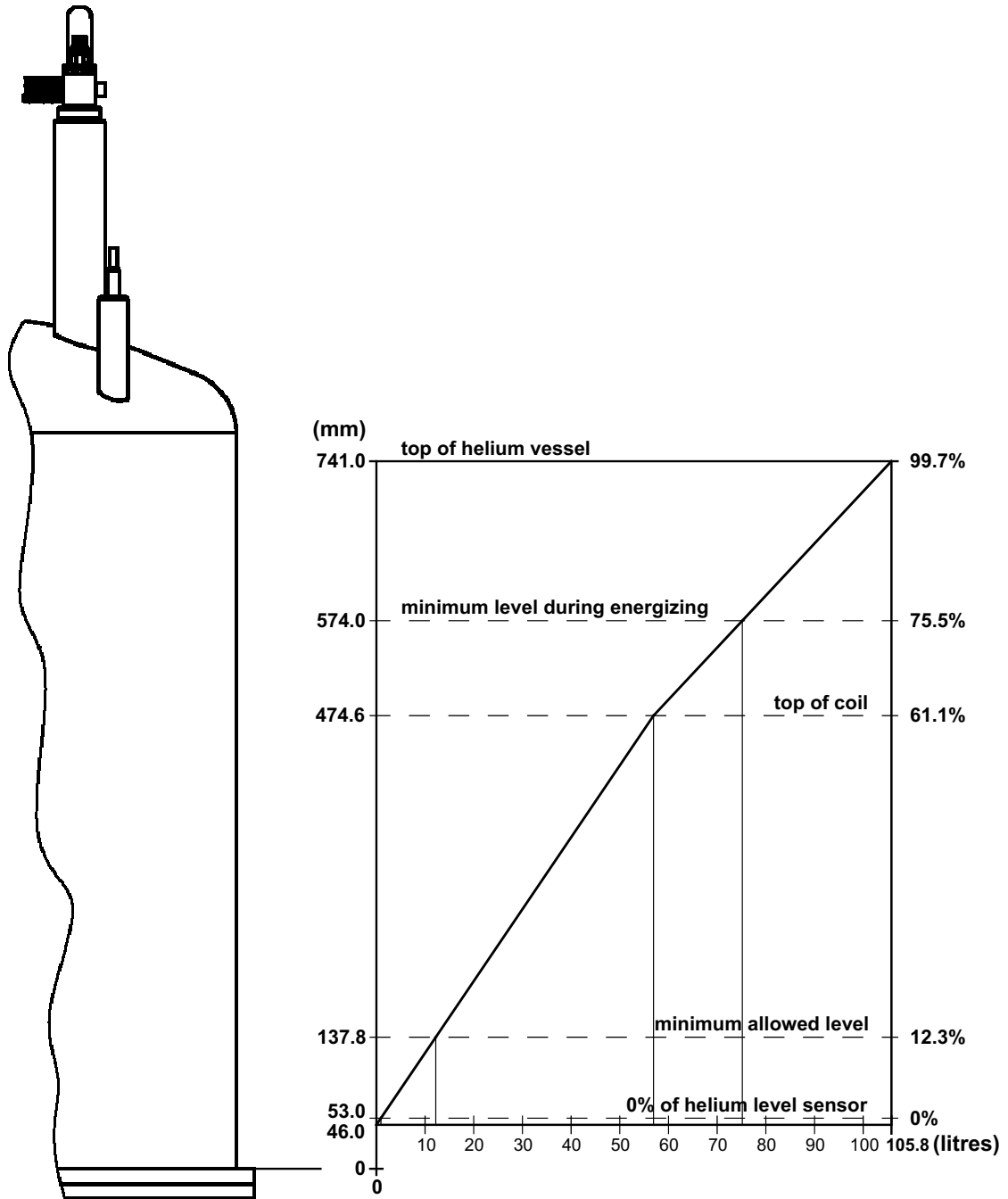

Figure 9.10: Helium Level Graph

9.13 Resistance at Room Temperature

Current lead used to energize magnet:

| | | |
|--|--|---|
| Current Lead, 55 Pin ○ 200 A (grey) | | HTS Current Lead, 55 Pin ○ 300 A (green) |
|--|--|---|

| | Pin | Connector | Description | Value | Unit |
|-------|-------------|----------------------|---------------------------------------|-------|------|
| From: | PIN V | 19 PIN Con CONTROL | Main Heater | | Ω |
| To: | PIN S | 19 PIN Con CONTROL | | | |
| From: | PIN D | 19 PIN Con CONTROL | Z Heater | | Ω |
| To: | PIN S | 19 PIN Con CONTROL | | | |
| From: | PIN G | 19 PIN Con CONTROL | X Heater | | Ω |
| To: | PIN S | 19 PIN Con CONTROL | | | |
| From: | PIN H | 19 PIN Con CONTROL | Y Heater | | Ω |
| To: | PIN S | 19 PIN Con CONTROL | | | |
| From: | PIN J | 19 PIN Con CONTROL | XZ Heater | | Ω |
| To: | PIN S | 19 PIN Con CONTROL | | | |
| From: | PIN K | 19 PIN Con CONTROL | YZ Heater | | Ω |
| To: | PIN S | 19 PIN Con CONTROL | | | |
| From: | PIN N | 19 PIN Con CONTROL | XY Heater | | Ω |
| To: | PIN S | 19 PIN Con CONTROL | | | |
| From: | PIN P | 19 PIN Con CONTROL | X ² -Y ² Heater | | Ω |
| To: | PIN S | 19 PIN Con CONTROL | | | |
| From: | PIN E | 19 PIN Con CONTROL | Z ² Heater | | Ω |
| To: | PIN S | 19 PIN Con CONTROL | | | |
| From: | PIN C,D,E,F | 10 PIN Con SHIM | Shim Coils +/- | | Ω |
| To: | PIN B,G,J,K | 10 PIN Con SHIM | | | |
| From: | PIN C,D,E,F | 10 PIN Con SHIM | Shim Coil + to Heater (common) | | Ω |
| To: | PIN S | 19 PIN Con CONTROL | | | |
| From: | + | High current Con | High Current + to Sense + | | Ω |
| To: | PIN T | 19 PIN Con CONTROL | | | |
| From: | + | High current Con | Main Coil | | Ω |
| To: | - | High current Con | | | |
| From: | - | High current Con | High Current - to Sense - | | Ω |
| To: | PIN U | 19 PIN Con CONTROL | | | |
| From: | PIN F | 19 PIN Con CONTROL | Z ³ Heater | | Ω |
| To: | PIN S | 19 PIN Con CONTROL | | | |
| From: | PIN T | 19 PIN Con CONTROL | Sense + Sense - | | Ω |
| To: | PIN U | 19 PIN Con CONTROL | | | |
| From: | PIN C,D,E,F | 10 PIN Con SHIM | Shim Coil + to Sense + | | Ω |
| To: | PIN T | 19 PIN Con CONTROL | | | |
| From: | PIN T | 19 PIN Con CONTROL | Sense + to Heater (common) | | Ω |
| To: | PIN S | 19 PIN Con CONTROL | | | |
| From: | PIN K | 10 PIN cool down Con | Upper temperature sensor PT 100 | | Ω |
| To: | PIN H | 10 PIN cool down Con | | | |
| From: | PIN A | 10 PIN cool down Con | IBT Carbon temperature sensor | | Ω |
| To: | PIN K | 10 PIN cool down Con | | | |
| From: | PIN A | 10 PIN cool down Con | Lower temperature sensor PT100 | | Ω |
| To: | PIN B | 10 PIN cool down Con | | | |
| From: | | All Connectors | Insulation Magnet to Cryostat | | Ω |
| To: | | Ground | | | |

Table 9.15: Resistance at Room Temperature

This page will be replaced by specific technical data.

9.14 Heater Currents

| Heater Currents | Value | Unit |
|---------------------|-------|------|
| Main heater current | | mA |
| Shim heater current | | mA |

Table 9.16: Heater currents

9.15 Shim Switch Heater

Heater operation during energizing / deenergizing

| Shim Switch | Heater Operation |
|--------------------------------|------------------|
| Z ⁰ | not detected |
| Z ¹ | automatic |
| Z ² | permanent |
| Z ³ | automatic |
| X | automatic |
| Y | automatic |
| XZ | automatic |
| YZ | automatic |
| XY | automatic |
| X ² -Y ² | automatic |

Table 9.17: Shim Switch Heater Operation

9.16 Energizing Assignment and Currents

Check the "minimum level during energizing" (see "[Helium Level Graph](#)" on page 71).

| Energizing Currents [A] | | | Sense Voltage [mV] | Remarks Bruker Test Site |
|---|----|------------------------|--------------------|--------------------------|
| 0 | to | 85.01 | 2500 | |
| 85.01 | to | 100.01 | 500 | |
| 100.01 | to | 104.04 | 200 | |
| Overshoot (0.3 % of final current) | | | | |
| Final current | to | Overshoot | 50 | |
| 10 minutes break at overshoot current | | | | |
| Overshoot | to | Final current | 50 | |
| Total energizing time [min] | | | | |
| 57 | | | | |
| Rate of current ramp-down with magnet in persistent mode [A/min] | | | | |
| 20 | | | | |
| Mandatory wait time between energizing and shimming [h] | | | | |
| 18 | | | | |

Table 9.18: Energizing assignment and currents

This page will be replaced by specific technical data.

9.17 Magnetic Center

| Magnetic Center | Value | Unit |
|--|-------|------|
| Distance magnetic center from top flange (MCT) | | mm |
| Distance magnetic center from bottom flange (MCB) | | mm |
| Shimsystem Offset (SO) see Figure 9.11: and refer to the supplied Test Protocol AST | | mm |

Table 9.19: Magnetic center

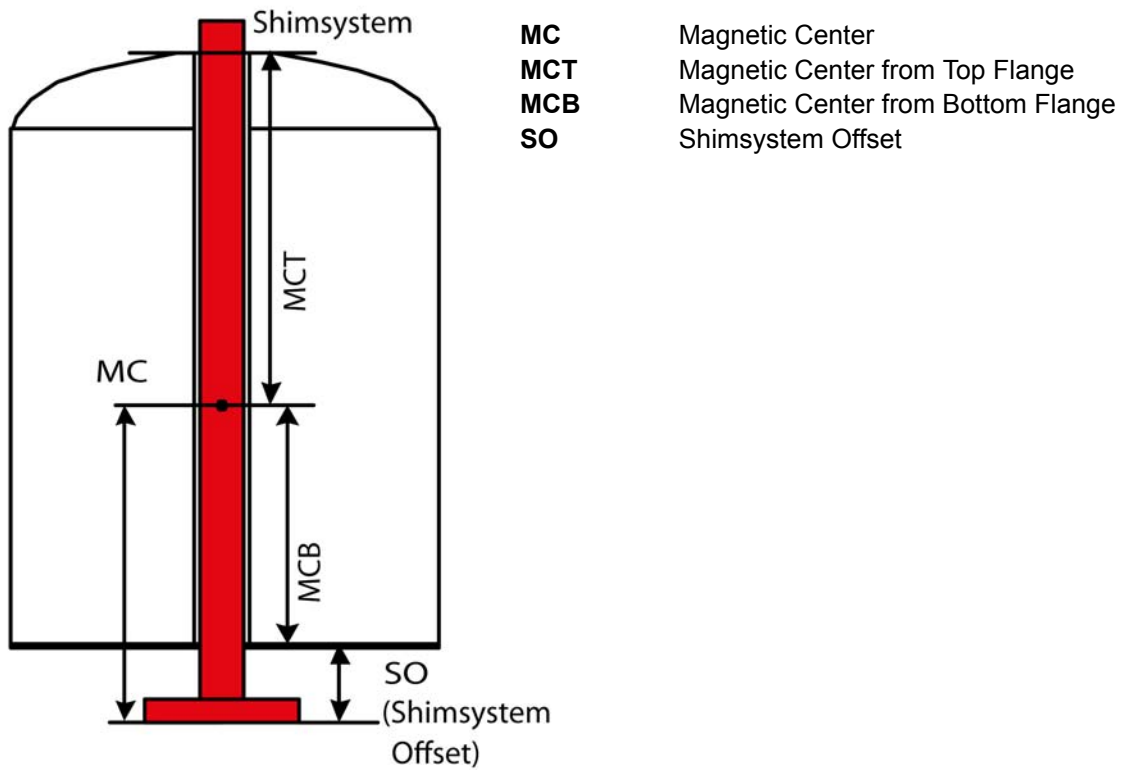

Figure 9.11: Magnetic center and shimsystem offset (SO)

This page will be replaced by specific technical data.

9.18 Cycling Assignment and Shim Currents

Cycling is recommended only for magnet systems at 500 MHz and more.

| Shim Currents | Value | Unit |
|---|-------|-------|
| Shim current rate | | A/min |
| Z ¹ Shim current | | A |
| Z ² Shim current | | A |
| Z ³ Shim current | | A |
| X Shim current | | A |
| Y Shim current | | A |
| XZ Shim current | | A |
| YZ Shim current | | A |
| XY Shim current | | A |
| X ² -Y ² Shim current | | A |
| Frequency change due to cycling | | kHz |
| Date and Signature | | |

Table 9.20: Cycling assignment and shim currents

This page will be replaced by specific technical data.

9.19 Energizing Currents

| Energizing Currents | Value at Customer Site #1 | Value at Customer Site #2 | Value at Customer Site #3 | Value at Customer Site #4 | Unit |
|---|---|---------------------------|---------------------------|---------------------------|------|
| Magnet main current | | | | | A |
| Z ¹ Shim current | | | | | A |
| Z ² Shim current | | | | | A |
| Z ³ Shim current | | | | | A |
| X Shim current | | | | | A |
| Y Shim current | | | | | A |
| XZ Shim current | | | | | A |
| YZ Shim current | | | | | A |
| XY Shim current | | | | | A |
| X ² -Y ² Shim current | | | | | A |
| Shimsystem Offset design value | Refer to the supplied Test Protocol AST | | | | mm |
| Shimsystem Offset Customer Site value | | | | | mm |
| Date and Signature | | | | | |

Table 9.21: Energizing currents

9.20 Deenergizing Assignment and Currents

| Deenergizing Currents [A] | | | Sense Voltage [mV] | Remarks Bruker Test Site |
|--------------------------------------|----|--------|--------------------|--------------------------|
| 104.03 | to | 102.00 | 200 | |
| 102.00 | to | 95.00 | 500 | |
| 95 | to | 0 | 1400 | |
| Total deenergizing time [min] | | | | |
| 47 | | | | |

Table 9.22: Deenergizing assignment and currents

*This page will be replaced
by specific technical data.*

This page is intentionally left blank.

9.21 Current Lead

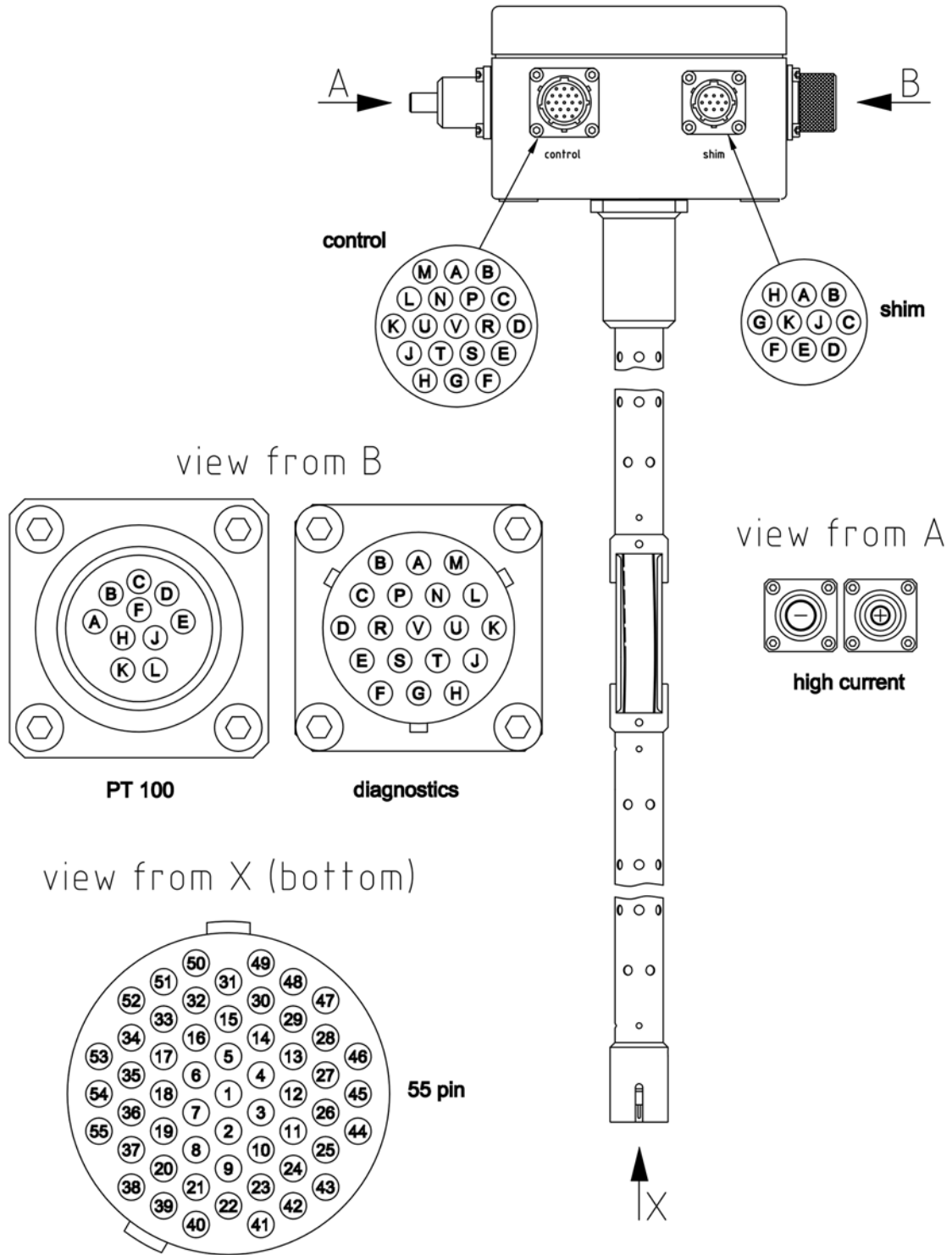

Z1029367

Figure 9.12: Current Lead 55 pin

9.21.1 Wiring Diagram Magnet

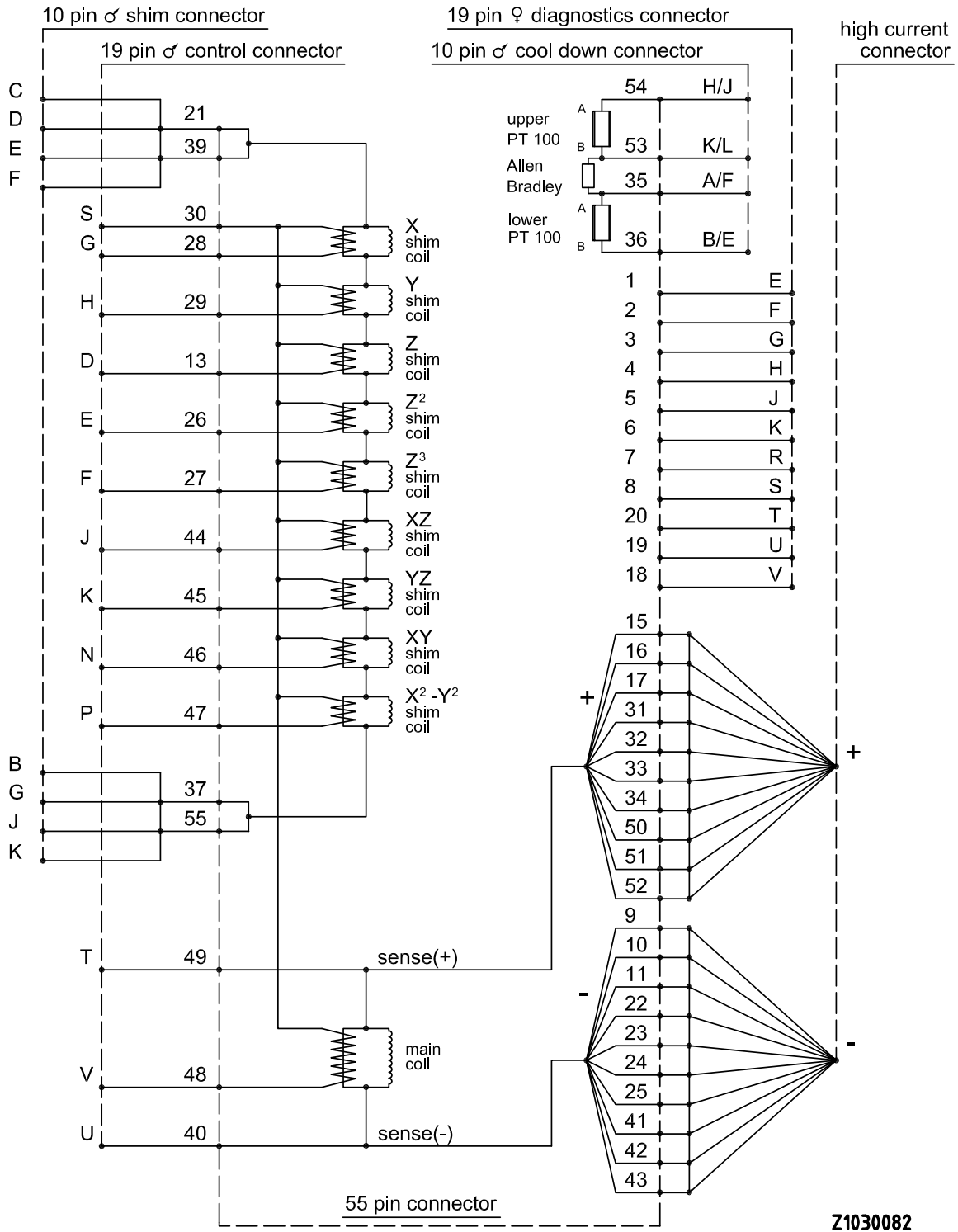
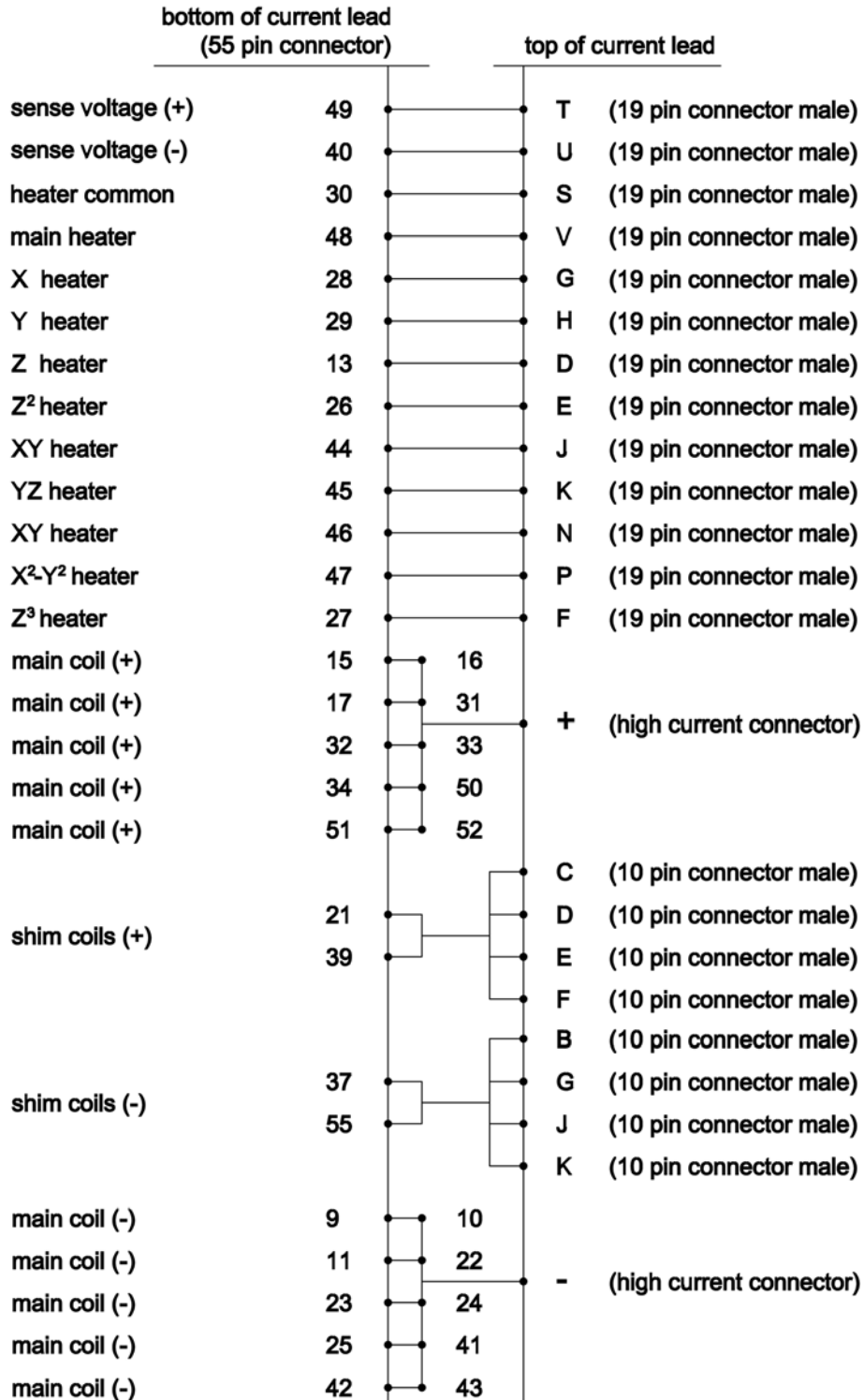

Figure 9.13: Wiring Diagram Magnet

9.21.2 Wiring Diagram Magnet Control and Shims



Z1029391

Figure 9.14: Wiring Diagram Magnet Control and Shims

9.21.3 Wiring Diagram Magnet Diagnostic and Temperature Sensors

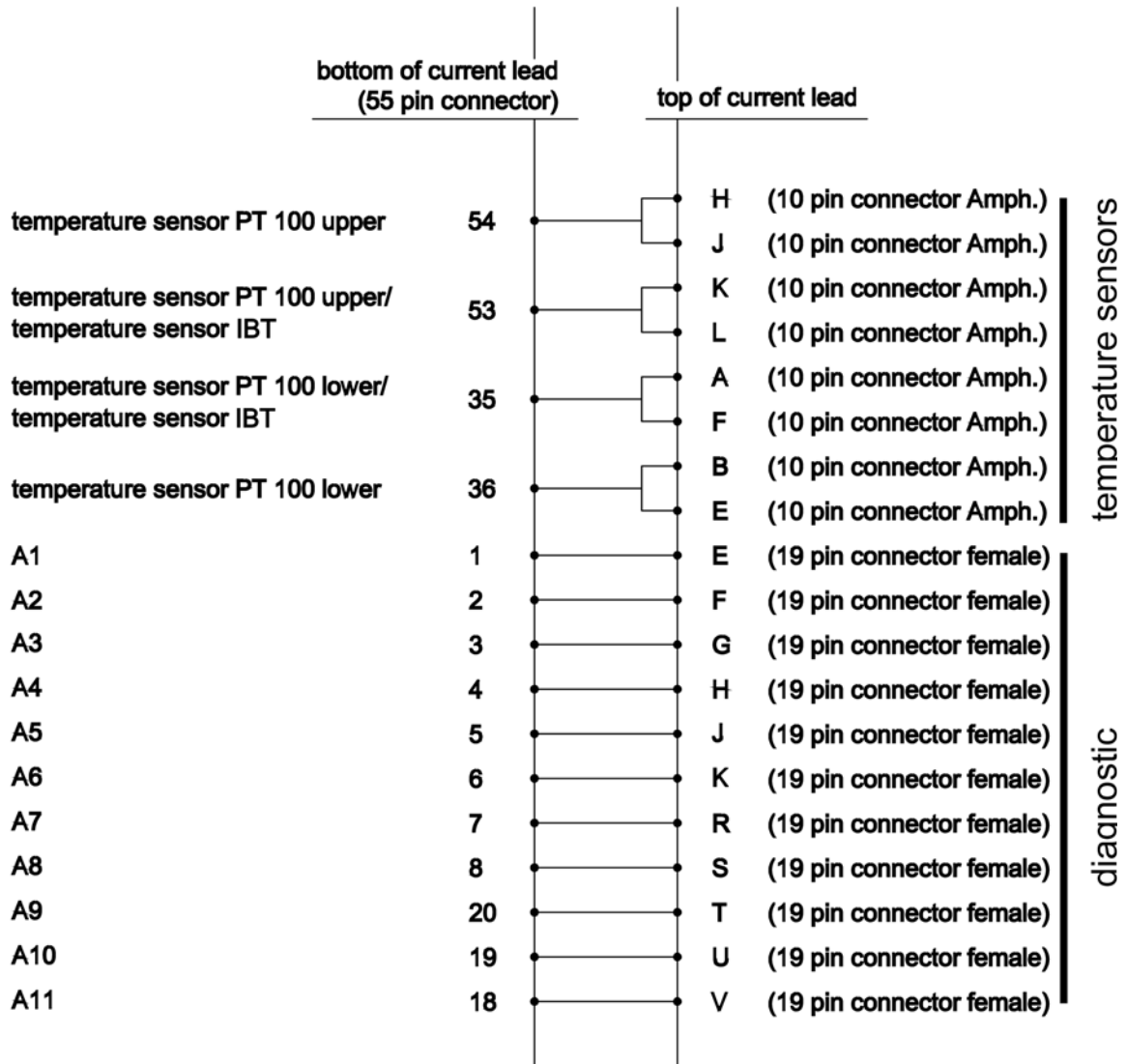

Z1029392

Figure 9.15: Wiring Diagram Magnet Diagnostic and Temperature Sensors

9.21.4 Shorting Plug

The shorting plug is plugged after removal of the current lead. After inserting the shorting plug the current flows through the shorting plug and no longer through the current lead and the power supply.

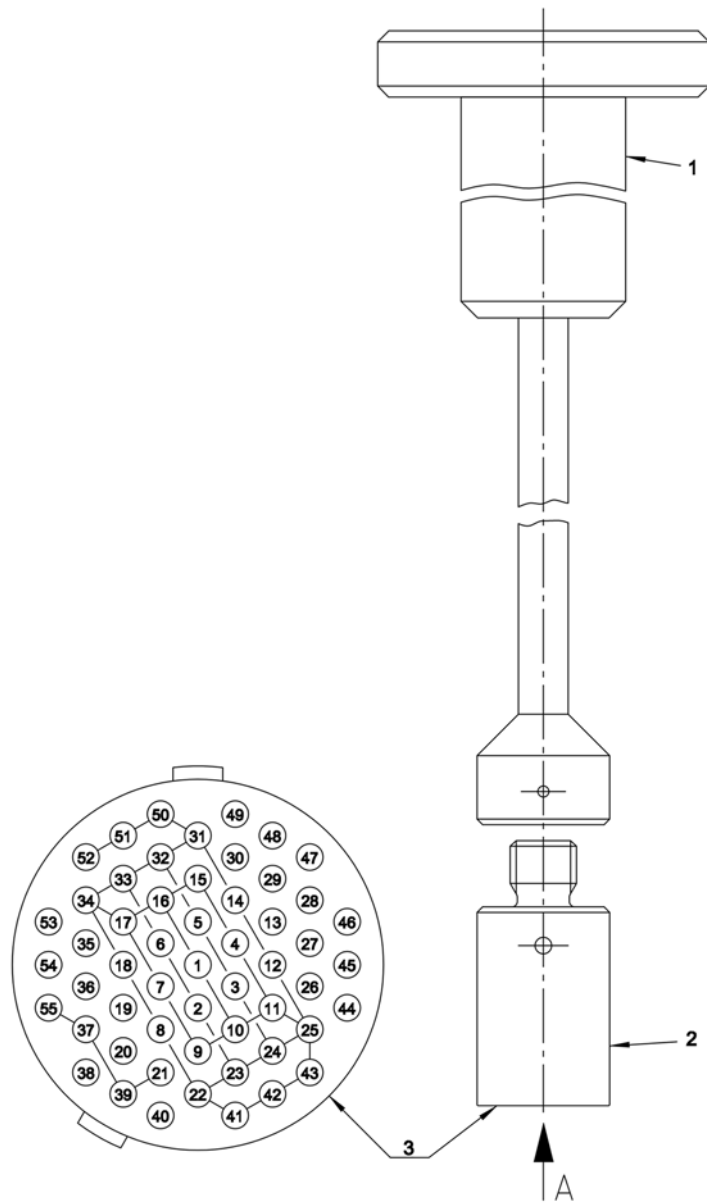

Z1029521

Figure 9.16: Shorting Plug 55 pins

- 1 Shorting Plug Tool for fitting and removing the shorting plug
- 2 Shorting Plug
- 3 Shorting Plug - view from pin side

Appendix A

A.1 Warning Signs

Danger

| | |
|---------------------------|----|
| Key Word and Symbol | 13 |
|---------------------------|----|

Warning

| | |
|--|----|
| Cryogenic Agents | 17 |
| Electricity | 17 |
| Gas under Pressure | 18 |
| Heavy Weights | 20 |
| Intended Use | 14 |
| Key Word and Symbol | 13 |
| Low Temperatures | 19 |
| Magnetic Field | 16 |
| Persons | 14 |
| Quench | 18 |
| Safety Devices | 15 |
| Signs and Labels | 16 |
| Slippage | 19 |
| Spare Parts | 15 |
| Spontaneous Ignition and Explosion | 19 |

Caution

| | |
|--------------------------------|----|
| Incorrect Transportation | 21 |
| Key Word and Symbol | 13 |

Notice

| | |
|---------------------------|----|
| Key Word and Symbol | 13 |
|---------------------------|----|

Safety Instructions

| | |
|---------------------------|----|
| Key Word and Symbol | 13 |
|---------------------------|----|

A.2 Figures

| | | |
|--------------|---|----|
| Figure 1.1: | General View of a Magnet System with 2 Helium Turrets | 10 |
| Figure 2.1: | Safety Devices of the Cryostat with 2 Helium Turrets..... | 24 |
| Figure 3.1: | Packaging (without surrounding panels)..... | 27 |
| Figure 3.2: | Transportation by Forklift - front side | 29 |
| Figure 3.3: | Transportation by Forklift - rear side | 29 |
| Figure 3.4: | Attachment Points for Lifting Equipment..... | 30 |
| Figure 3.5: | Instruction Label for Lifting Equipment..... | 30 |
| Figure 5.1: | Start the Magnet Stand | 36 |
| Figure 5.2: | Stop the Magnet Stand | 36 |
| Figure 6.1: | Magnet system during a quench..... | 52 |
| Figure 9.1: | Dimensions of the cryostat (front view)..... | 59 |
| Figure 9.2: | Dimensions of the cryostat (top view) | 61 |
| Figure 9.3: | Safety valves of the cryostat | 62 |
| Figure 9.4: | Nitrogen Level Sensor | 63 |
| Figure 9.5: | Helium Level Sensor | 64 |
| Figure 9.6: | Characteristic Curve of PT 100 Sensor | 65 |
| Figure 9.7: | Characteristic Curve of IBT Carbon Sensor..... | 66 |
| Figure 9.8: | Fringe field plot of the magnet system at maximum field | 68 |
| Figure 9.9: | Nitrogen Level Graph..... | 70 |
| Figure 9.10: | Helium Level Graph | 71 |
| Figure 9.11: | Magnetic center and shimssystem offset (SO) | 75 |
| Figure 9.12: | Current Lead 55 pin | 79 |
| Figure 9.13: | Wiring Diagram Magnet | 80 |
| Figure 9.14: | Wiring Diagram Magnet Control and Shims..... | 81 |
| Figure 9.15: | Wiring Diagram Magnet Diagnostic and Temperature Sensors..... | 82 |
| Figure 9.16: | Shorting Plug 55 pins | 83 |

A.3 Tables

| | | |
|-------------|--|----|
| Table 7.1: | Maintenance Timetable | 54 |
| Table 7.2: | Maintenance-free Components of the Magnet System..... | 54 |
| Table 9.1: | Environmental conditions | 57 |
| Table 9.2: | Weight of the magnet system | 58 |
| Table 9.4: | Dimensions of the cryostat – front view | 60 |
| Table 9.5: | Dimensions of the cryostat – top view | 61 |
| Table 9.6: | Opening pressure of the safety valves of the magnet system | 62 |
| Table 9.7: | Nitrogen Level Sensor | 63 |
| Table 9.8: | Helium Level Sensor | 64 |
| Table 9.9: | Characteristic Values of PT 100 Sensor | 65 |
| Table 9.10: | Characteristic Values of IBT Carbon Sensor..... | 66 |
| Table 9.11: | Specification of the Magnet..... | 67 |
| Table 9.12: | Fringe field data of the magnet system at maximum field..... | 68 |
| Table 9.13: | Cryogenic Agents Consumption during Installation | 69 |
| Table 9.14: | Cryogenic Agents..... | 69 |
| Table 9.15: | Resistance at Room Temperature | 72 |
| Table 9.16: | Heater currents | 73 |
| Table 9.17: | Shim Switch Heater Operation..... | 73 |
| Table 9.18: | Energizing assignment and currents..... | 74 |
| Table 9.19: | Magnetic center | 75 |
| Table 9.20: | Cycling assignment and shim currents | 76 |
| Table 9.21: | Energizing currents | 77 |
| Table 9.22: | Deenergizing assignment and currents | 77 |

A.4 Glossary / Abbreviations

| Glossary | Description |
|-------------------|---|
| Cryostat | The collective of all parts providing a temperature of 4 K inside for the superconducting magnet. The cryostat also provides the safety devices and the access ports for the cryogenic agents and electricity. The superconducting magnet inside the cryostat is not energized. |
| Dewar | Any kind of package used for transporting cryogenic agents like liquid helium or nitrogen. |
| Pressure Cylinder | Any kind of package used for transporting gaseous agents with a pressure up to 200 bar. |
| Magnet System | The collective of all parts necessary for the intended use. The superconducting magnet inside the cryostat is energized. |

| Abbreviations | Description |
|---------------|--|
| ACD | Automatic Cooling Device |
| MICS | Magnet Information and Control System |
| NMR | Nuclear Magnetic Resonance |
| RS | Radiation Shield |
| RT | Room Temperature; used as prefix of parts which are at room temperature |

Revision History List

| Index: | Date: | Alteration Type: |
|---------------|-------------------|---|
| 00 | October 2010 | First release. |
| 01 | April 2011 | Update including nitrogen level sensor. |
| 02 | September 2012 | Update of fringe field data and related directives. |
| 03 | February 2013 | Update of magnetic center. |
| 04 | June 2013 | New layout of title page and last page. |
| 05 | March 2017 | Update of Technical Data; inserted shim-system offset, shim switch heater operation and mandatory wait time after energizing. Update of magnet stand, fringe field data and Helium flow system. |
| | | |
| | | |
| | | |
| | | |



Bruker Corporation

info@bruker.com
www.bruker.com

Order No: Z31928