

# 400'54 Ascend ULH

- User Manual

Version 05



Copyright © by Bruker Corporation

All rights reserved. No part of this publication may be reproduced, stored in a retrieval system, or transmitted, in any form, or by any means without the prior consent of the publisher. Product names used are trademarks or registered trademarks of their respective holders.

This manual was written by

Renate Petry

© February 11, 2019: Bruker Corporation

Faellanden, Switzerland

ZTKS0173 / Z31990 / 05

For further technical assistance on the NMR Magnet System, please do not hesitate to contact your nearest BRUKER dealer or contact us directly at:

BRUKER BioSpin AG  
Industriestrasse 26  
CH-8117 Faellanden  
Switzerland

Phone: + 41 44 825 91 11  
FAX: + 41 44 825 96 96  
E-mail: [2nd-level-support.bbio@bruker.com](mailto:2nd-level-support.bbio@bruker.com)  
Internet: [www.bruker.com](http://www.bruker.com)

---

<b>Contact .....</b>	<b>7</b>
<b>1 Introduction.....</b>	<b>9</b>
1.1 General Information.....	9
1.2 Limitation of Liability .....	9
1.3 Customer Service.....	9
1.4 Warranty.....	9
1.5 Copyright.....	9
1.6 General View.....	10
<b>2 Safety.....</b>	<b>11</b>
2.1 Approved Persons.....	11
2.2 Customer Responsibilities.....	12
2.3 Key Words.....	13
2.4 Residual Risks.....	15
2.4.1 Persons.....	15
2.4.2 Intended Use.....	15
2.4.3 Safety Devices.....	16
2.4.4 Spare Parts.....	16
2.4.5 Signs and Labels.....	17
2.4.6 Technical Risks.....	17
2.5 Personal Protective Equipment.....	23
2.6 Description of Signs and Labels.....	24
2.7 Safety Devices.....	25
2.8 Behavior in Danger and Emergency Situations.....	27
2.9 Fire Department Notification.....	27
<b>3 Transportation.....</b>	<b>29</b>
3.1 Safety.....	29
3.2 Packaging.....	29
3.2.1 Disposal.....	30
3.3 Transport Inspection.....	30
3.4 Transportation by Fork Lift / Pallet Jack.....	31
3.5 Transportation with a Crane.....	32
3.6 Storing.....	33
3.7 Disposal.....	33
<b>4 Assembling.....</b>	<b>35</b>
<b>5 Operation.....</b>	<b>37</b>
5.1 Safety.....	37
5.2 Set into Operation.....	38

<b>6</b>	<b>Troubleshooting .....</b>	<b>39</b>
6.1	Safety .....	39
6.2	Problem .....	40
6.2.1	During Transportation.....	40
6.2.2	During Assembling .....	40
6.2.3	During Cooling Procedure .....	42
6.2.4	During Energizing and Shimming.....	46
6.2.5	During Operation of the Magnet Stand.....	49
6.2.6	During Standard Operation.....	51
6.2.7	During Deenergizing and Warming .....	53
6.3	Troubleshooting Work .....	54
6.3.1	After a Quench .....	54
<b>7</b>	<b>Maintenance.....</b>	<b>55</b>
7.1	Safety .....	55
7.2	Cleaning .....	55
7.3	Maintenance Timetable .....	56
7.4	Maintenance-free Components .....	56
<b>8</b>	<b>Disassembling .....</b>	<b>57</b>
<b>9</b>	<b>Technical Data MS 400'54 Ascend ULH .....</b>	<b>59</b>
9.1	Environmental Conditions.....	59
9.2	Identification Plate .....	59
9.3	Dimensions.....	60
9.3.1	Weights.....	60
9.3.2	Dimensions for Transportation .....	60
9.3.3	Dimensions Cryostat .....	61
9.4	Safety Valves.....	64
9.5	Nitrogen Level Sensor .....	65
9.6	Helium Level Sensor .....	66
9.7	Temperature Sensors.....	67
9.8	Technical Data Magnet.....	69
9.9	Fringe Field Plot .....	70
9.10	Filling Volume, Evaporation Rate and Hold Time.....	71
9.11	Nitrogen Level Graph .....	72
9.12	Helium Level Graph.....	73
9.13	Resistance at Room Temperature.....	74
9.14	Heater Currents .....	75
9.15	Shim Switch Heater .....	75
9.16	Energizing Assignment and Currents .....	76
9.17	Magnetic Center .....	77

9.18	Cycling Assignment and Shim Currents.....	78
9.19	Cryo Shim Currents.....	79
9.20	Deenergizing Assignment and Currents.....	79
9.21	Current Lead .....	81
9.21.1	Wiring Diagram Magnet.....	82
9.21.2	Wiring Diagram of Current Lead - Magnet Control and Shims.....	83
9.21.3	Wiring Diagram of Current Lead 55 Pin - Cool Down and Diagnostics.....	84
9.21.4	Shorting Plug.....	85
9.22	Nitrogen Refill Report.....	86
9.23	Helium Refill Report .....	88
<b>Appendix A .....</b>		<b>91</b>
A.1	Warning Signs .....	91
A.2	Figures .....	93
A.3	Tables.....	95
A.4	Index.....	97



# Contact

## **Manufacturer**

Bruker BioSpin AG

Industriestrasse 26

CH-8117 Faellanden

Switzerland

Phone: + 41 44 825 91 11

Fax: + 41 44 825 96 96

<http://www.bruker.com>

E-mail: [2nd-level-support.bbio@bruker.com](mailto:2nd-level-support.bbio@bruker.com)

Please refer to the Model No., Serial No. and Internal Order No. in all correspondence regarding the NMR system or components thereof.



# 1 Introduction

## 1.1 General Information

---

This manual contains important information about the handling of the supplied magnet system used for NMR spectroscopy and its components. The compliance with all safety and handling instructions, the applicable local accident prevention and general safety regulations are necessary for safe work.

This manual is part of the product. It must be kept nearby the magnet system and free access must be ensured at any time. Read the manual carefully before handling the magnet system or its components.

## 1.2 Limitation of Liability

---

The information in this manual will take into account the current state of the technology.

The manufacturer assumes no liability for damages resulting from:

- non-compliance with the instructions and all applicable documentation,
- use for purposes not intended,
- not sufficiently approved persons,
- arbitrary changes or modifications and
- use of not approved spare parts or accessories.

## 1.3 Customer Service

---

Technical support is provided by Bruker Service via telephone or e-mail. For contact information see [page 7](#) of this document.

## 1.4 Warranty

---

The warranty terms can be found in the sales documents of the magnet system and in the Terms and Conditions of Bruker BioSpin AG.

## 1.5 Copyright

---

No part of this publication may be reproduced, stored in a retrieval system, or transmitted, in any form or by any means without the prior consent of the publisher. Product names used are trademarks or registered trademarks of their respective holders.

## 1.6 General View

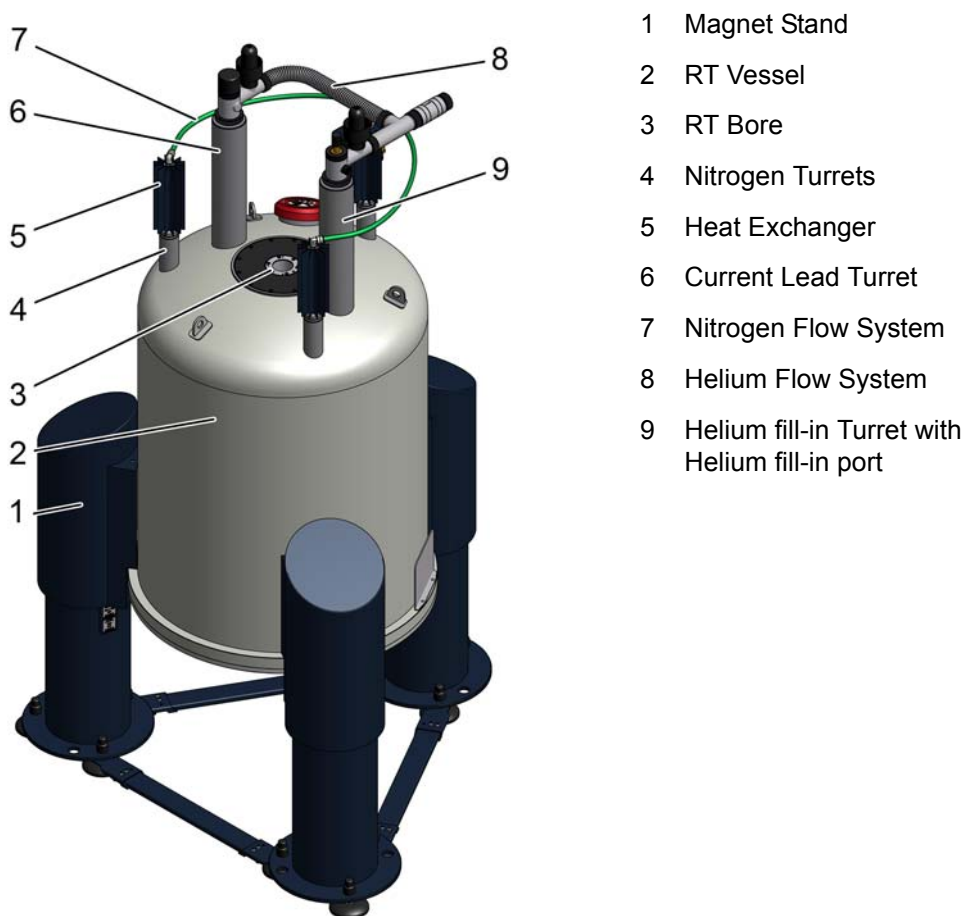

Figure 1.1: General view of a magnet system with 2 helium turrets

The heart of the NMR magnet system is a superconducting magnet located inside the helium vessel, which is filled with liquid helium. The helium vessel is surrounded by a nitrogen vessel filled with liquid nitrogen. The outer casing, the room temperature (RT) vessel (2), contains the helium vessel and the nitrogen vessel. The vacuum in the RT vessel reduces thermal conduction. The RT bore (3) allows the access to the magnetic center. RT vessel, inner vessels, turrets, flow systems and the RT bore together build the cryostat of the magnet system.

The cryostat is mounted on a magnet stand (1). The isolators in the magnet stand absorb floor vibrations. Different heights and isolators are available optionally.

The nitrogen turrets (4) connected with the nitrogen flow system (7) and the heat exchangers (5) are the interface to the nitrogen vessel. The nitrogen fill-in turret is marked with a green label.

The helium turrets (6, 9) connected with the helium flow system (8) are the interface of the helium vessel and the magnet coil. The helium fill-in turret (9) is marked with a yellow label.

The current lead turret (6) is the interface for energizing the magnet coil and for diagnostic.

## 2 Safety

The supplied cryostat and further equipment of the magnet system were designed and manufactured according to the best available technical knowledge and practice, achieved in over 50 years of experience of the Bruker Corporation. International standards for quality and approval recommended for cryostats of superconducting magnets were certified.

Nevertheless non-compliance with the following instructions and safety advice may cause serious hazards and property damage.

### 2.1 Approved Persons

---

Bruker BioSpin AG identifies the following qualifications for personnel performing tasks on the magnet system or its components:

#### **Approved Customer Personnel**

As a result of professional training by Bruker Service Personnel, experience and knowledge of applicable regulations these persons are qualified to perform the specific tasks on the magnet system and its components assigned to them in this manual. Approved Customer Personnel are qualified to identify possible hazards and risks associated with the tasks assigned to them and to perform all possible steps to eliminate or minimize these risks.

#### **Bruker Service Personnel**

These persons are qualified by appropriate qualification and professional training and experience (including all necessary knowledge of applicable regulations and regulatory requirements) to perform specific tasks on the magnet system and its components. Bruker Service Personnel are qualified to identify possible hazards and risks and to perform all possible steps to eliminate or minimize these risks.

## 2.2 Customer Responsibilities

---

The customer must obey the security advice and the rules for safety, applicable local accident prevention and environmental protection correctly for the magnet system. Furthermore, the customer is responsible for keeping the magnet system in good technical condition.

**In particular:**

- The customer must identify additional dangers resulting from the working conditions at the site of the magnet system and provide applicable safety measures.
- The customer must ensure that the site plan meets the specified conditions according to the site planning document for operating the magnet system.
- The customer must clearly mark the danger area around the magnet system and post the corresponding instruction plates.
- The customer has to ensure the intended use of the magnet system.
- The customer has to inform the local fire brigade about the special risks of the magnet system and how to react in the event of an incident.
- The customer must clearly define the responsibilities for operation and maintenance.
- The customer must ensure that all employees working with the magnet system have read and understood the manual.
- The customer has to provide the necessary personal protective equipment for his employees.
- The customer has to instruct his employees at regular intervals on hazards and safety measures.
- The customer has to instruct other persons not working on the magnet system but carrying out work in the same room, for instance cleaning staff or guards about the possible danger at the site of the magnet system.
- The customer must ensure that maintenance is performed according to the schedule listed in chapter [Maintenance Timetable on page 56](#).

## 2.3 Key Words

Safety instructions in this manual and labels of devices are marked with symbols. The safety instructions are introduced using indicative words which express the extent of the hazard.

In order to avoid accidents, personal injury or damage to property, always observe safety instructions and proceed with care.

### DANGER



**DANGER:** Indicates a hazardous situation that, if not avoided, will result in death or serious injury. This signal word is limited to the most extreme situations.

This is the consequence of not following the warning.

1. This is the safety condition.
- ▶ This is the safety instruction.

### WARNING



**WARNING:** Indicates a hazardous situation that, if not avoided, could result in death or serious injury.

This is the consequence of not following the warning.

1. This is the safety condition.
- ▶ This is the safety instruction.

### CAUTION



**CAUTION:** Indicates a hazardous situation that, if not avoided, could result in minor or moderate injury.

This is the consequence of not following the warning.

1. This is the safety condition.
- ▶ This is the safety instruction.

## **NOTICE**

**NOTICE:** Indicates information considered important, but not hazard-related (e.g. messages relating to property damage).

This is the consequence of not following the notice.

1. This is a safety condition.
  - ▶ This is a safety instruction.

## **SAFETY INSTRUCTIONS**

**SAFETY INSTRUCTIONS** are used for control flow and shutdowns in the event of an error or emergency.

This is the consequence of not following the safety instructions.

1. This is a safety condition.
  - ▶ This is a safety instruction.



---

This symbol highlights useful tips and recommendations as well as information designed to ensure efficient and smooth operation.

---

## 2.4 Residual Risks

---

In the following chapter the residual risks from applicable risk analysis are summarized. To prevent health hazards and hazardous situations obey all safety instructions and warnings in the manual.

### 2.4.1 Persons

---

#### WARNING



##### **Risk of injury and property damage due to handling by not approved persons.**

Incorrect handling of the magnet system by not approved persons may result in significant bodily injury and property damage.

- ▶ Work must only be carried out by approved persons with applicable qualifications. The necessary qualifications are specified in the beginning of the relevant chapter.
- ▶ In case of doubt, contact Bruker Service. Contact information see [page 7](#) of this document.

### 2.4.2 Intended Use

---

The supplied magnet system is designed and intended for NMR spectroscopy only.

#### WARNING



##### **Risk of damage to life and limb by incorrect use of the magnet system.**

Incorrect use of the magnet system can lead to life-threatening situations and destruction of the magnet system.

- ▶ Only use the magnet system as intended.
- ▶ Do not change the magnet system.
- ▶ Do not exceed specified values for operating the magnet system.
- ▶ Do not use inserts inside the RT bore not approved by Bruker Service.

Damage claims from damages caused by other than the intended use of the magnet system are excluded and the customer is held liable.

## 2.4.3 Safety Devices

---

### **WARNING**



#### **Risk of damage to life and limb due to not sufficient safety devices.**

Several safety devices ensure safe operation of the magnet system. They must always be in correct working condition.

- ▶ Do not block safety devices.
- ▶ Do not remove safety devices.
- ▶ Check the operational reliability of the safety devices before working on the magnet system.

## 2.4.4 Spare Parts

---

### **WARNING**



#### **Risk of injury and property damage from using incorrect or defective spare parts and accessories.**

Incorrect or defective spare parts can cause serious injuries. They may cause damaging, malfunctioning and the destruction of the magnet system.

- ▶ Only use original equipment manufacturer spare parts.
- ▶ Only use original equipment manufacturer accessories.

## 2.4.5 Signs and Labels

---



### **WARNING**

#### **Risk of damage to persons and property due to not readable signs and labels.**

Signs and labels with advice may become not readable.

- ▶ Maintain signs and labels in a readable state.
- ▶ Replace damaged or not readable signs and labels immediately. New signs and labels can be ordered from Bruker Service.

## 2.4.6 Technical Risks

---

### Magnetic Field



### **WARNING**

#### **Risk of damage to life and limb due to high magnetic fields.**

A magnetic field of more than 0.5 mT (5 Gauss) is life-threatening for people with pacemakers or active metal implants. Exposure to more than 8 T can cause damage to health. Duration of exposure (8 h/day) above the limit of 200 mT can cause damage to health. Ferromagnetic tools in the magnetic field are significantly hazardous. Disks and electronic devices may be damaged.

- ▶ Mark the magnetic field of more than 0.5 mT (5 Gauss) before start up.
- ▶ Keep people with active medical implants away from the 0.5 mT (5 Gauss) area.
- ▶ The permanent workplace of employees must be outside the 0.5 mT (5 Gauss) area.
- ▶ Do not stay or work at magnetic fields of more than 8 T.
- ▶ Prevent exposure of more than 200 mT for more than 8 h/day.
- ▶ Keep disks, credit cards and electronic devices away from the identified area.
- ▶ Do not use ferromagnetic tools or items within the identified area.
- ▶ Only use non-ferromagnetic transportation dewars or pressure cylinders for the cryogenic agents.
- ▶ Only use non-ferromagnetic ladders or steps.

## Cryogenic Agents



### **WARNING**

#### **Risk of damage to life and limb due to cryogenic agents.**

Risk of damage to life and limb due to not correct handling of liquid cryogenic agents. Within the transition from liquid to gas, helium and nitrogen expand their volume, causing closed vessels or transportation dewars to burst. The evaporating cryogenic agents will displace the breathing air. Helium displaces the breathing air in the upper part of the room, nitrogen displaces the breathing air in the lower parts of the room. In case of not sufficient ventilation this may result in death by suffocation.

Liquid and gaseous cryogenic agents are extremely cold. Contact with liquid or gaseous cryogenic agents will lead to cold burns. Contact with the eyes may cause blindness. Refer to Warning: Low Temperature on page 20.

- ▶ Only use cryogenic agents in well ventilated rooms. In case of doubt ask Bruker Service.
- ▶ Wear an oxygen monitor on the body during service and maintenance work.
- ▶ Prevent any skin contact with liquid or gaseous cryogenic agents.

## Electricity



### **WARNING**

#### **Risk of damage to life and limb due to electricity.**

Risk of damage to life and limb due to contact with electrical lines and damaged insulation.

- ▶ Work on electrical equipment must be done by an approved electrical technician.
- ▶ Keep moisture away from electrical lines to prevent short-circuits.
- ▶ Check the magnet system electrical grounding before start.
- ▶ Switch the power OFF before working on the Bruker Power Supply or further equipment.

## Quench



### WARNING

#### **Risk of suffocation during a quench of the magnet system.**

A quench is the very fast deenergizing of the magnet by loss of its superconductivity. The stored magnetic energy is converted into heat and thus large quantities of helium evaporate. The evaporating helium will displace the breathing air. In case of not sufficient ventilation this may result in death by suffocation.

- ▶ The magnet system site must be well ventilated. In case of doubt contact Bruker Service.
- ▶ The evaporating gas may resemble smoke. Never pour water on the magnet system.

## Gas under Pressure



### WARNING

#### **Risk of injury due to gas under pressure inside the cryostat and further equipment.**

The helium or the nitrogen vessel of the cryostat may get sealed off due to ice formation inside the helium or the nitrogen turrets in case of non-compliance with the instruction given in this manual. This may lead to overpressure and damage of the helium or the nitrogen vessel.

Manipulations of components with gas under pressure may lead to injury and property damage.

- ▶ In case of ice inside the helium or the nitrogen turrets contact Bruker Service immediately.
- ▶ Release the pressure to the recommended value before working on components with gas under pressure.
- ▶ Do not seal cryogenic agent vessels of the magnet system or the transportation dewars.
- ▶ Do not connect high pressure transportation dewars to the magnet system. Completely eliminate the high pressure from the transportation dewars before connecting and transferring cryogenic agents.

## Low Temperature

### WARNING



#### **Risk of injury due to low temperature of liquids and metal parts.**

Physical contact with extremely cold liquids and metal parts may cause serious injuries. Contact with the skin may cause cold burns. Contact with the eyes may cause blindness.

- ▶ Always wear protective goggles, protective gloves and protective clothes while handling with liquid cryogenic agents or metal parts in contact with liquid cryogenic agents.
- ▶ Protect temperature sensitive components such as O-rings from contact with liquid cryogenic agents.

## Spontaneous Ignition and Explosion

### WARNING



#### **Risk of injury from spontaneous ignition and explosion caused by liquid oxygen.**

Pure oxygen condenses on extremely cold metal pieces. Together with oil it may ignite spontaneously. In case of fire the pure oxygen may cause an explosion.

- ▶ Do not smoke near the magnet system.
- ▶ Do not use open flames near the magnet system.
- ▶ Keep the environment around the magnet system clean.
- ▶ Do not leave oily rags near the magnet system.

## Risk of Slippage

### WARNING



#### **Risk of injury from slippage.**

The accumulation of condensed water on the floor and ladders causes slippery surfaces.

- ▶ Always wear safety shoes with an anti-slip sole.
- ▶ Be careful using ladders.
- ▶ Clean floor and ladders regularly.

### Risk of Tilting



#### **WARNING**

##### **Risk of injury due to tilting of the magnet system.**

The magnet system is very sensitive to lateral forces. It may tilt.

- ▶ Do not climb onto the magnet system.
- ▶ Do not lean items against the magnet system.
- ▶ Do not lean against the magnet system.
- ▶ Do not move the magnet system on your own.

### Heavy Weights



#### **WARNING**

##### **Risk of damage to life and limb caused by heavy weights.**

Lifting heavy weights is life-threatening due to falling or moving parts.

- ▶ Do not stay or work under a lifted magnet system.
- ▶ All lifting equipment in use must be approved to carry the weight.
- ▶ Do not use damaged lifting equipment.
- ▶ Do not use lifting equipment without updated check tag.
- ▶ Lifting only with approved qualification.
- ▶ Obey ergonomic guidelines while lifting heavy parts.
- ▶ Protect parts against falling.
- ▶ Always wear safety shoes with approved toe caps.

## Transportation

### CAUTION

#### **Risk of injury and property damage due to incorrect transportation.**

The boxes may tilt, movement may get out of control. Thus persons may get injured and the cryostat or further equipment may be damaged.

- ▶ Be careful while unloading and moving the boxes.
- ▶ Do not move the boxes arbitrarily.
- ▶ Pay attention to all symbols on the boxes.
- ▶ Pay attention to sharp edges and spikes of boxes and parts by using protective gloves while moving.
- ▶ Move the boxes in an upright position.
- ▶ Do not tilt the boxes.
- ▶ Prevent crossing thresholds, even if they are only a few millimeters high.
- ▶ Clean the transportation way before moving the box.
- ▶ Unpack shortly before assembling.
- ▶ The cryostat or further equipment must be protected from rain and other bad weather conditions during transportation.
- ▶ Exclusively move the cryostat in its original box.
- ▶ Do not remove the tightening straps inside the box until assembling.
- ▶ Only use the provided attachment points.
- ▶ Ensure that the cryostat is always leveled during any transportation.
- ▶ Transportation only with attached transportation locks.
- ▶ Do not move the evacuated cryostat.
- ▶ Do not move the cryostat after cool down.



## 2.5 Personal Protective Equipment

---

The personal protective equipment must be worn at any time while working on the magnet system and further equipment to prevent health hazards.



### Protective Goggles

Used to protect the eyes from injury due to flying cold liquids and parts.



### Protective Gloves

Used to protect the hands from injury caused by contact with extremely cold liquids or surfaces and for protection from injury caused by rough edges.



### Protective Clothes

Used to protect the body from injury caused by contact with extremely cold liquids or surfaces and for protection from wounds.



### Safety Shoes

Used to protect the feet from injury from falling of heavy objects. An anti-slip sole protects from injury caused by slipping and falling on slippery floor and steps. Only use safety shoes with non-ferromagnetic toe caps.

### Portable Oxygen Monitor and Alarm

Used to warn against low oxygen concentration in the air.

## 2.6 Description of Signs and Labels

---

Signs and labels are always related to their immediate vicinity. The following signs and labels are found on the magnet system and in the vicinity.



**Prohibition sign: No person with pacemakers!**

People with pacemakers are endangered in the identified area of 0.5 mT (5 Gauss) and are not allowed to enter these areas.



**Prohibition sign: No person with implants!**

People with metallic implants are endangered in the identified area of 0.5 mT (5 Gauss) and are not allowed to enter these areas.



**Prohibition sign: No watches or electronic devices!**

Watches and electronic devices may be damaged in the identified area of 0.5 mT (5 Gauss).



**Prohibition sign: No credit cards or other magnetic memory!**

Credit cards and magnetic memory may be damaged in the identified area of 0.5 mT (5 Gauss).



**Prohibition sign: Do not touch! Do not block!**

Do not touch or block the identified area.



**Hazard warning sign: Strong magnetic field!**

- No magnetic memory.
- No jewelry.
- No metallic items.



**Helium fill-in port**

- Use only this port for helium refill!
- Do not leave the helium ports open for more than 5 seconds!



**Emergency exit!**

- Always keep the emergency exit clear.
- Follow the arrows if necessary.
- Doors must be pushed open in escape direction.

## 2.7 Safety Devices

The supplied cryostat of the magnet system is equipped with the following safety devices:

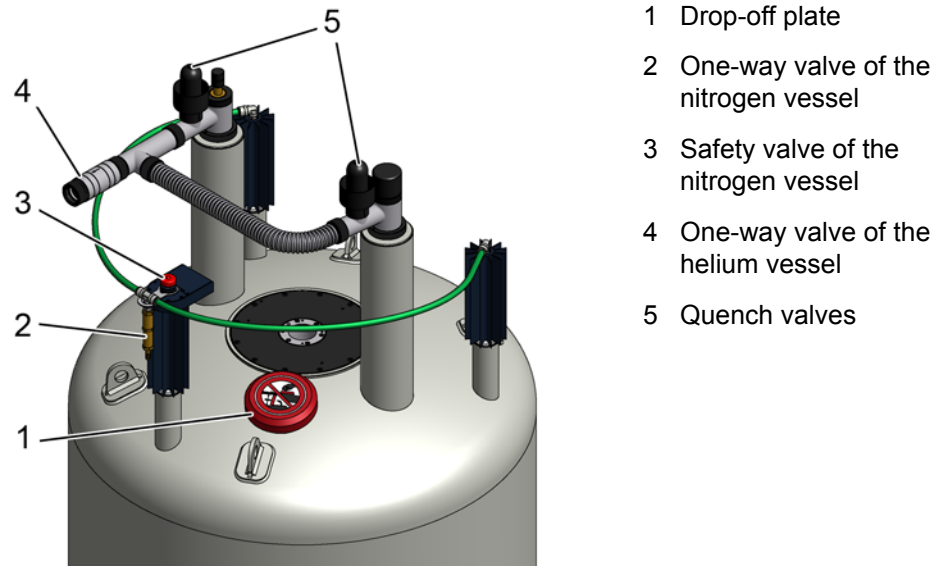

Figure 2.1: Safety devices of the cryostat with 2 helium turrets

## **Quench Valve**

The quench valves (5) are the safety devices of the helium vessel. They open with a defined pressure. In case of an accidental overpressure in the helium vessel the quench valves will release the pressure smoothly.

## **Safety Valve**

The safety valve (3) is the safety device of the nitrogen vessel. It opens with a defined pressure. In case of an accidental overpressure in the nitrogen vessel the safety valve will release the pressure smoothly.

## **Drop-off Plate**

The drop-off plate (1) is a safety device of the RT vessel. If the vacuum breaks, the drop-off plate will open. In case of an accidental overpressure in the RT vessel the drop-off plate will release the pressure smoothly.

## **One-way Valves**

The one-way valves of the nitrogen flow system (2) and of the helium flow system (4) keep air and moisture from entering the nitrogen vessel or the helium vessel in case of an accidental underpressure inside the vessels.

## 2.8 Behavior in Danger and Emergency Situations

---

### Preparations

- Keep the emergency exits free at all times.
- Prepare and maintain an up-to-date list of emergency telephone numbers in the magnet system area.

### In Case of Emergency

- Leave the danger zone immediately.
- Check for sufficient ventilation in the room before entering, especially if people are showing symptoms of suffocation.
- Rescue persons from the danger zone.
- Provide medical attention for people with symptoms of suffocation.
- Start first aid immediately.
- Call the responsible contact.
- Call for medical assistance.
- Call the fire department.

### First Aid for Cold Burns

- Help the injured persons to lie down comfortably in a warm room.
- Loosen all clothing which could prevent blood circulation in the injured area.
- Pour large quantities of warm water over the affected parts.
- Cover the wound with dry and sterile gauze.
- In case of contact of liquid cryogenic agents with the eyes rinse thoroughly with clean water.
- Call for medical assistance.

## 2.9 Fire Department Notification

---

- Inform the fire department about the technical risks of a magnet system, like danger due to ferromagnetic rescue equipment near the magnet system.
- Laboratory windows which are accessible during an emergency should be clearly identified with warning signs, visible from the outside.
- Inform the fire department about the characteristics of a quench to prevent confusion with smoke.
- Never pour water over the magnet system during a quench!



# 3 Transportation

## 3.1 Safety

---

The transportation is carried out by Bruker Service or approved persons. However, it may happen that other persons have to receive the delivery of the shipping boxes. In this case it is essential to obey the instructions in this chapter and to inform these persons before.



### ⚠ WARNING

Heavy Weights (see [page 21](#))



### ⚠ CAUTION

Transportation (see [page 22](#))

## 3.2 Packaging

---



The cryostat is supplied in a wooden box on a pallet. It is secured inside with straps against tilting and moving.

Accessories such as the flow systems, level sensors and bore tubes are in the side compartment of the box.

The Magnet Stand is supplied in a wooden box on a pallet.

Figure 3.1: Packaging (without surrounding panels)

## 3.2.1 Disposal

---

Keep the original boxes for future transportation.

If no further transportation is planned, dispose of the boxes according to environmentally friendly regulations.

## 3.3 Transport Inspection

---

Investigate the delivery with regard to visible damage and completeness of delivery.

### Transport control systems

The shipping and handling monitors (Shock Watch, Tilt Watch) on the boxes show if the boxes were kicked or tilted during transportation.

### Checks

Shock Watch: Follow instructions on the label.

Tilt Watch: Follow instructions on the label.

### In case of damage

- Accept delivery with reservation.
- Make a documentation of all observable damage and add it to the transportation documents.
- Start complaint process.
- Contact Bruker Service before installation.

---

The claim for damage expires after the fixed period.



Thus:

Report damages to Bruker Service immediately after detection of damage. For contact information see [page 7](#) of this document.

---

## 3.4 Transportation by Fork Lift / Pallet Jack

A fork lift is recommended for transporting the boxes to the installation site.

**Approved Persons:** Approved forklift / pallet jack operator

**Precondition:** The fork lift / pallet jack must be approved for the transportation weight (refer to the supplied Sales Information).

### Transport



Figure 3.2: Transportation by fork lift – front view

1. Check the route of transport for the minimal height and width.
2. Check sufficient floor capacity on the route of transport. In case of doubt ask a stress analyst.
3. Check sufficient carrying capacity while using an elevator.
4. Position the forks between the bars of the box as shown in the figure. Make sure the side towards the operator is the one with the labels on it.



Figure 3.3: Transportation by fork lift – rear view

5. Make sure the forks of the fork lift are longer than the box and projects out of the back of the box as shown in the figure.
6. Now lift the fork and move the box to the site.

## 3.5 Transportation with a Crane

A crane is recommended for lifting the cryostat out of the box.

**Approved Persons:** Approved crane operator

**Precondition:** The crane must be approved for the transportation weight (see [Weights on page 60](#)).

### Attachment Points



1. Exclusively use the marked eyelets as attachment points for the lifting equipment.
2. Use **all** eyelets for the lifting equipment.

Figure 3.4: Attachment points for lifting equipment

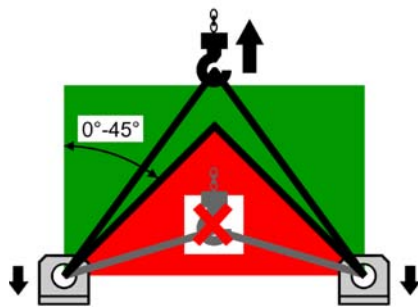

3. Follow the instructions on the label on top of the cryostat. This label gives important information about correct attachment and transportation.
4. Check for correct fastening of the lifting equipment before lifting the cryostat.
5. Make sure that any movement of the crane is as slowly as possible to avoid any damage due to acceleration.
6. Check for correct leveling of the cryostat while hanging on the crane.

Figure 3.5: Instruction label for lifting equipment

## 3.6 Storing

---

If it is necessary to store the cryostat and accessories before installation obey the following instructions:

- Store the boxes in a closed, dry and dust-free room.
- Store the boxes upright.
- Do not tilt the boxes.
- Do not unpack the supplied boxes.
- Prevent mechanical vibrations to the boxes.
- Storage temperature: 5 – 40 °C.
- Storage humidity: less than 50% @ 23 °C.

## 3.7 Disposal

---

For disposal after the life cycle please contact Bruker Service for further information. For contact information see [page 7](#) of this document.



# 4 Assembling

Approved Persons: Bruker Service only



# 5 Operation

## 5.1 Safety

---

### Approved Persons

Bruker Service, Approved Customer Personnel

### WARNING



**Magnetic Field (see [page 17](#))**

**Cryogenic Agents (see [page 18](#))**

**Electricity (see [page 18](#))**

**Gas under Pressure (see [page 19](#))**

## 5.2 Set into Operation

---



Figure 5.1: Start the magnet stand

If the magnet system is equipped with a magnet stand with pneumatic isolators:

Set the magnet stand into operation by switching the pneumatic controller to UP position.



Figure 5.2: Stop the magnet stand

For any work at the magnet system like maintenance or refill of cryogenic agents stop the magnet stand by switching the pneumatic controller to DOWN position.

# 6 Troubleshooting

Troubleshooting must be performed only with approved qualification.

In case of doubts or problems not specified in the following list contact Bruker Service immediately. For contact information see [page 7](#) of this manual.

## 6.1 Safety

---

Only approved persons should perform the troubleshooting tasks. They are outlined in this chapter:

- Bruker Service
- Approved Customer Personnel

### WARNING



**Magnetic Fields (see [page 17](#))**

**Cryogenic Agents (see [page 18](#))**

**Electricity (see [page 18](#))**

**Gas under Pressure (see [page 19](#))**

**Spontaneous Ignition and Explosion (see [page 20](#))**

#### **Personal protective equipment**

- Protective goggles
- Protective gloves
- Protective clothes
- Safety shoes

## 6.2 Problem

### 6.2.1 During Transportation

Indicator	Possible reason	Solution	Performed by
Tilt Watch / Shock Watch activated.	Careless transportation.	<ol style="list-style-type: none"> <li>1. Accept delivery with reservation.</li> <li>2. Remark the extent of damage in the transportation documents.</li> <li>3. Start complaint process.</li> </ol>	Approved Customer Personnel
Visible damage.	Careless transportation.	<ol style="list-style-type: none"> <li>1. Accept delivery with reservation.</li> <li>2. Remark the extent of damage in the transportation documents.</li> <li>3. Start complaint process.</li> </ol>	Approved Customer Personnel

### 6.2.2 During Assembling

Indicator	Possible reason	Solution	Performed by
Ceiling height too low for assembling on magnet stand.	Site does not meet the required conditions.	Choose another site that meets the required conditions.	Bruker Service
Ceiling height too low for inserting the Helium Level Sensor.	Site does not meet the required conditions.	Insert the Helium Level Sensor before mounting the magnet stand.	Bruker Service
Helium bore and radiation shield are not centered.	Alignment is not correct.	Check fitting of the alignment rods.	Bruker Service
	Alignment rod is loose or broken.	Replace alignment rod <sup>a</sup> .	Bruker Service
	Reduction flange is not centered.	Check the position of the reduction flange.	Bruker Service

Table continued

Indicator	Possible reason	Solution	Performed by
Vacuum valve is touching the magnet stand.	Vacuum valve mounted incorrectly.	Reposition the vacuum valve.	Bruker Service
Vacuum in RT vessel does not reach $5 \times 10^{-5}$ mbar within 48 hours.	O-rings may be damaged.	Check and clean O-rings and slots. If necessary, replace the O-rings for <ul style="list-style-type: none"> <li>• the vacuum valve</li> <li>• the drop-off plate</li> <li>• the reduction and sealing flanges</li> <li>• the bottom plate <sup>a</sup>.</li> </ul>	Bruker Service
	Defective pumping unit or pumping line.	Check pumping unit and pumping line: A vacuum of at least $10^{-6}$ mbar must be reached while the sealing plug is closed. Replace if necessary.	Bruker Service
	Room temperature bore has scratches or dust on the sealing surfaces.	Check sealing surfaces on the RT bore: No scratches and no dust should be visible.	Bruker Service
	Moisture in the RT vessel.	Use dry N <sub>2</sub> gas to pump and flush the RT vessel.	Bruker Service
Super insulation is touching the RT vessel or the RT bore or the radiation shield.	Super insulation was not attached correctly during assembling.	Attach the super insulation on the outer radiation shield using polyester tape <sup>a</sup> . Carefully prevent any contact of the vessels or the RT bore in the cryostat.	Bruker Service

a. This work requires to remove the bottom plate. Before removing the bottom plate check that the suspension tubes of the helium vessel are not broken. Install the safety device for fall protection (not supplied). Contact Bruker Service for further information.

## 6.2.3 During Cooling Procedure

Indicator	Possible reason	Solution	Performed by
Cooling with liquid nitrogen is too slow.	Empty transportation dewar.	Refill or replace transportation dewar.	Bruker Service
	Transfer pressure too low.	Increase transfer pressure slightly (max. pressure 0.3 bar).	Bruker Service
	Transportation dewar is leaky; no transfer pressure can be applied.	Check transportation dewar and replace if necessary.	Bruker Service
Precooling with liquid nitrogen occurs too quickly.	Transfer pressure too high.	Stop cooling. Adjust correct transfer pressure.	Bruker Service
Vacuum in RT vessel does not reach $5 \times 10^{-5}$ mbar within 48 hours.	O-rings are leaky.	Check and clean O-rings and slots. If necessary, replace the O-rings for <ul style="list-style-type: none"> <li>• the vacuum valve</li> <li>• the drop-off plate</li> <li>• the reduction and sealing flanges</li> <li>• the bottom plate <sup>a</sup>.</li> </ul>	Bruker Service
	O-rings are frozen due to contact with liquid nitrogen.	<ol style="list-style-type: none"> <li>1. Stop cooling.</li> <li>2. Warm O-rings with warm air.</li> <li>3. Wait until the vacuum is recovered.</li> <li>4. Prevent liquid nitrogen from splashing on O-rings.</li> </ol>	Bruker Service
	Pumping unit or pumping line is defective.	Check pumping unit and pumping line: A vacuum of at least $10^{-6}$ mbar must be reached while the sealing plug is closed. Replace if necessary.	Bruker Service

a. See note on previous page.

Table continued

Indicator	Possible reason	Solution	Performed by
RT vessel becomes cold and wet.	Vacuum is broken or less than $10^{-3}$ mbar.	<ul style="list-style-type: none"> <li>Keep the pumping unit connected until filling with liquid helium is finished.</li> <li>Continue as in problem <i>Vacuum in RT vessel does not reach <math>10^{-6}</math> mbar.</i></li> </ul>	Bruker Service
	Cold leak after transportation.	<ol style="list-style-type: none"> <li>Stop cooling.</li> <li>Warm the cryostat.</li> </ol>	Bruker Service
Cold spot in the RT bore.	Alignment not correct.	<ol style="list-style-type: none"> <li>Stop cooling.</li> <li>Warm the cryostat.</li> <li>Align the vessels.</li> </ol>	Bruker Service
The helium flow system becomes very cold and icy during flushing with helium gas.	Liquid nitrogen remains in the helium vessel, boiling off strongly during flushing.	<ol style="list-style-type: none"> <li>Stop flushing.</li> <li>Carefully remove all liquid nitrogen using the precooling tube.</li> <li>Use the dipstick to check that the helium vessel is empty (no liquid nitrogen or frozen nitrogen).</li> </ol>	Bruker Service
After some intervals of flushing it is not possible to reach a vacuum in the range of 1 mbar.	The globes in the quench valves are not fitting correctly in the O-rings and thus the quench valves are leaky.	<ol style="list-style-type: none"> <li>Stop pumping.</li> <li>Remove frozen air and frozen moisture using warm helium gas.</li> <li>Apply a small amount of grease to the O-rings and check the position of the globes.</li> <li>Use the dipstick to check that the helium vessel is empty (no liquid nitrogen or frozen nitrogen).</li> </ol>	Bruker Service
	Liquid nitrogen remains in the helium vessel, boiling off strongly during flushing.	<ol style="list-style-type: none"> <li>Stop pumping.</li> <li>Use the precooling tube to remove all liquid nitrogen.</li> <li>Use the dipstick to check that the helium vessel is empty (no liquid nitrogen or frozen nitrogen).</li> </ol>	Bruker Service

Table continued

Indicator	Possible reason	Solution	Performed by
Nitrogen ice in the helium vessel.	Times between pumping and flushing were too long. Nitrogen boiled off during pumping and remaining nitrogen got frozen during flushing.	<ol style="list-style-type: none"> <li>1. Warm the magnet coil with warm helium gas by using the precooling tube until the whole coil is at 90 K or above.</li> <li>2. Repeat pumping and flushing.</li> <li>3. Use the dipstick to check that the helium vessel is empty (no liquid nitrogen or frozen nitrogen).</li> </ol>	Bruker Service
Transfer of liquid helium does not start.	The transportation dewar is empty.	Refill or replace transportation dewar.	Bruker Service
	The transfer pressure in the transportation dewar is too low.	Increase the transfer pressure.	Bruker Service
	The transportation dewar is leaky, no transfer pressure is built up.	Check the transportation dewar for leakage. Re-tighten all connections.	Bruker Service
	The siphon or the helium transfer line are blocked with ice.	Check the siphon and helium transfer line for blockages. Remove ice with warm helium gas.	Bruker Service

Table continued

Indicator	Possible reason	Solution	Performed by
The cooling of the magnet coil does not continue although helium is transferred.	The helium transfer line is defective.	Check the helium transfer line for ice. If there are cold spots visible, replace the helium transfer line.	Bruker Service
	The extension piece is not mounted on the helium transfer line.	Mount the extension piece on the helium transfer line. Check the helium transfer line is completely inserted into the siphon.	Bruker Service
The zero reading of the Helium Level Sensor can not be adjusted at the beginning of cooling with liquid helium.	The Helium Level Sensor is not connected correctly with the connector in the helium flow system.	Check the connection in the helium fill-in turret between Helium Level Sensor and connector.	Bruker Service
	The Helium Level Sensor is defective.	Check the Helium Level Sensor using the 0 % calibration plug.	Bruker Service
The helium level does not reach 100 % after cooling.	Empty transportation dewar, helium transfer stopped.	Refill or replace transportation dewar.	Bruker Service
	The Helium Level Sensor is disturbed by the transfer line's extension piece.	<ol style="list-style-type: none"> <li>1. Stop the liquid helium transfer.</li> <li>2. Remove the transfer line.</li> <li>3. Wait for a few minutes.</li> <li>4. Measure the helium level to check the Helium Level Sensor is working correctly.</li> </ol>	Bruker Service
After cooling the rate of helium boil off is higher than specified (up to 5 times).	Usual behavior. A few days are necessary for the radiation shields and the insulation to reach scheduled temperatures.	<p>Wait a few days and check helium boil off.</p> <p>The presence of the current lead in the current lead turret during energizing and shimming helps cooling the radiation shield due to higher helium flow.</p>	Bruker Service

## 6.2.4 During Energizing and Shimming

Indicator	Possible reason	Solution	Performed by
The current lead can not be inserted completely into the connector.	The connector is covered with ice (frozen moisture or nitrogen ice).	Carefully remove the ice with warm helium gas. Use the dipstick or the precooling tube as tubing for the warm helium gas to remove small ice spots.	Bruker Service
	The shorting plug was not removed.	Remove the shorting plug with the shorting plug tool.	Bruker Service
	The orientation of the current lead is not correct.	Carefully reposition the current lead until it can be inserted correctly into the connector.	Bruker Service
Main coil heater test fails.	Power supply defective.	Replace the power supply.	Bruker Service
	Connector or cables defective.	Clean connectors or replace cables, if necessary.	Bruker Service
Setting of sense voltage fails.	The main coil heater switch is "OFF". The main coil switch is not opened.	Switch the main coil heater to "ON" and check the main coil heater current to be adjusted correctly.	Bruker Service
	The main coil heater current is not correct. The main coil switch is not opened.	Adjust main coil heater current correctly.	Bruker Service
	The auxiliary shorting plug is inserted in the current lead turret by mistake and makes a short circuit across the main coil.	Remove the auxiliary shorting plug and insert it in the helium fill-in turret.	Bruker Service

Table continued

Indicator	Possible reason	Solution	Performed by
Current lead can not be removed.	The connector is covered with ice (frozen moisture or nitrogen ice).	Carefully remove the ice with warm helium gas over the helium flow system. Use the dipstick or the precooling tube as tubing for the warm helium gas to remove small ice spots from the connector.	Bruker Service
Shorting plug can not be removed.	The connector is covered with ice (frozen moisture or nitrogen ice).	Carefully remove the ice with warm helium gas. Use the dipstick or the precooling tube as tubing for the warm helium gas to remove small ice spots from the connector.	Bruker Service
The magnet system quenches.	Loss of superconductivity.	See <a href="#">After a Quench on page 54</a> .	Bruker Service
	The helium level was too low for energizing, cycling, shimming, deenergizing or sweeping.	See <a href="#">After a Quench on page 54</a> .	Bruker Service
	The power supply is defective. The main current is oscillating.	Replace the power supply.	Bruker Service
The main coil switch can not be closed on field.	The helium level is too low for energizing. The main coil switch is not covered with liquid helium.	Never try to energize the magnet with a helium level less than the "minimum level during energizing" in the helium vessel.	Bruker Service
	The power supply is defective. The main current is oscillating.	Replace the power supply.	Bruker Service

Table continued

Indicator	Possible reason	Solution	Performed by
Shim current can not be set correctly.	The control cable is not connected correctly to the current lead or to the power supply.	Connect the control cable correctly to the current lead and to the power supply.	Bruker Service
	The switch „Main Coil/OFF/Shim Coil“ is in the wrong position.	Change the switch position.	Bruker Service
Shims do not affect the NMR signal.	Shim heater current is not correct. The shim switches are not opened.	Set the shim heater current to the specified value (See <a href="#">Energizing Assignment and Currents on page 76</a> ).	Bruker Service
Magnet system does not reach specification.	Magnetic material inside RT bore tube.	Carefully clean the RT bore tube.	Bruker Service
	Large ferromagnetic parts near the magnet system.	<ol style="list-style-type: none"> <li>As much as possible, keep all ferromagnetic parts away from the magnet system.</li> <li>Repeat shimming.</li> </ol>	Bruker Service

## 6.2.5 During Operation of the Magnet Stand

More information is available in the Magnet Stand manual.

Indicator	Possible reason	Solution	Performed by
The NMR spectrum shows massive disturbances.	Pneumatic controller is in DOWN position.	Switch pneumatic controller to UP position.	Approved Customer Personnel
	Magnet system is touching the floor via accessories or cables.	Identify and eliminate contact point. Arrange cables in loose S- or U-shapes.	Approved Customer Personnel
		If the problem is still not solved, contact Bruker Service.	Approved Customer Personnel
	Magnet system is touching the magnet stand.	Check the level; adjust if necessary.	Approved Customer Personnel
	Piston of the isolator is not centered or is touching its casing.	Align magnet stand.	Bruker Service
	T-safety bracket is touching the pillar.	Align magnet stand.	Bruker Service
	Floor vibrations in vertical direction.	Replace elastomeric isolators with air damped isolators.	Bruker Service
	Floor vibrations in horizontal and vertical direction.	Replace air damped isolators with air piston isolators.	Bruker Service

Table continued

Indicator	Possible reason	Solution	Performed by
The pneumatic isolator of the magnet stand does not reach the operating position.	Pneumatic controller in DOWN position.	Switch pneumatic controller to UP position.	Approved Customer Personnel
	The pressure of the gas supply is too low.	Check the pressure of the pneumatic supply. It must be in the range of 5 to 8 bar (70 to 112 psi).	Approved Customer Personnel
		If the problem is still not solved, contact Bruker Service.	Approved Customer Personnel
	The magnet system is not level.	Stop the pneumatic isolators. Check the level of the cryostat.	Bruker Service
	Defective leveling valve.	Replace leveling valve or isolator.	Bruker Service
	Defective membrane of an isolator.	Replace leveling valve or isolator.	Bruker Service
The movement of the magnet stand is not smooth.	Piston is not centered or is touching its casing.	Align magnet stand.	Bruker Service
Audible loss of gas.	Defective membrane or defective leveling valve of an isolator.	Replace leveling valve or isolator.	Bruker Service
	Hose connector is defective or loose.	Insert hoses correctly and tighten screws.	Bruker Service
The movement of the magnet stand is too fast.	Incorrect adjustment of the flow control valve.	Close fully the flow control valve; then open ½ turn.	Bruker Service

## 6.2.6 During Standard Operation

Indicator	Possible reason	Solution	Performed by
The helium boil off decreases to zero.	The atmospheric pressure is increasing.	Usual behavior. Check the helium boil off daily.	Approved Customer Personnel
	The helium flow system is covered with ice.	Contact Bruker Service immediately! Do not try to remove ice from the helium flow system!	Approved Customer Personnel
	<b>⚠ WARNING:</b> <b>Cryogenic Agents</b> <b>Quench</b>		
	The helium flow system or the suspension tubes are blocked with ice.	Flush warm helium gas through an applicable tube. Do not insert the tube more than 600 mm from the top of the helium turrets.	Bruker Service
The helium boil off is too high.	The Helium Level Sensor is in service mode or has been used too often.	Switch off Helium Level Sensor. Reduce frequency of helium level measurement (during measuring of the helium level an amount of helium boils off due to the heat input of the Helium Level Sensor).	Approved Customer Personnel
	The atmospheric pressure is decreasing.	Usual behavior. Check the helium boil off daily.	Approved Customer Personnel
		If it continues, contact Bruker Service.	Approved Customer Personnel
	Vacuum reduced.	Rebuild vacuum, see chapter <i>Rebuilding Vacuum</i> in the service manual.	Bruker Service
	The radiation baffles are not inserted in the current lead turret.	Insert the radiation baffles into the current lead turret.	Bruker Service

Table continued

Indicator	Possible reason	Solution	Performed by
Quench.	Loss of superconductivity.	see <a href="#">After a Quench on page 54</a> . Contact Bruker Service immediately!	Approved Customer Personnel
Cold spots in the RT bore.	Alignment of the vessels not correct.	Contact Bruker Service.	Approved Customer Personnel
RT vessel is wet and cold.	Vacuum reduced.	Contact Bruker Service immediately!	Approved Customer Personnel
Helium level warning out of MICS is false.	Helium Level Sensor defective.	Contact Bruker Service immediately!	Approved Customer Personnel
Helium level at constant level, no change during days.	Helium Level Sensor defective.	Contact Bruker Service immediately!	Approved Customer Personnel
		<b>⚠ WARNING:</b> <b>Low Temperature</b>	
Helium level warning out of MICS is false.	Helium Level Sensor defective.	Replace Helium Level Sensor (see chapter <i>Replacement of the Helium Level Sensor</i> in the service manual).	Bruker Service
Helium level at constant level, no change during days.	Helium Level Sensor defective.	Replace Helium Level Sensor (see chapter <i>Replacement of the Helium Level Sensor</i> in the service manual).	Bruker Service

## 6.2.7 During Deenergizing and Warming

Indicator	Possible reason	Solution	Performed by
The magnet system quenches during deenergizing.	The helium level was too low for deenergizing.	Refill helium at least to the minimum allowed level.	Bruker Service
	The Power Supply is defective.	Replace Power Supply.	Bruker Service
	The main current is oscillating.	Replace Power Supply.	Bruker Service
The shim current can not be set correctly.	The control cable is not connected correctly to the current lead and/or the Power Supply.	Connect the control cable to the current lead and to the Power Supply correctly.	Bruker Service
	The switch "Main Coil/OFF/Shim Coil" is not on the "Shim Coil" position.	Switch "Main Coil/OFF/Shim Coil" on the "Shim Coil" position.	Bruker Service
High helium flow after breaking vacuum.	Remaining cryogenic agents in the vessels.	Remove liquid cryogenic agents.	Bruker Service
Vacuum still remains after 12 hours.	Vacuum valve is closed.	Open the vacuum valve. Block it if necessary.	Bruker Service
RT vessel is wet and cold.	Cryostat is still cold.	Wait until RT vessel is dry and warm. Check PT100 temperature sensors.	Bruker Service
RT bore is wet and cold before disassembling.	Cryostat is still cold.	Wait one more day. Do not open a cryostat before the room temperature bore tube is warm and dry!	Bruker Service

## 6.3 Troubleshooting Work

---

### 6.3.1 After a Quench

---



A quench is the very fast deenergizing of the magnet by loss of its superconductivity. The stored magnetic energy is converted into heat, which promotes rapid evaporation of large quantities of helium.

If a quench occurs contact Bruker Service immediately.

Figure 6.1: Magnet system during a quench



#### **⚠ WARNING**

**Cryogenic Agents (see [page 18](#))**

**Quench (see [page 19](#))**

#### **Quench while in persistent mode:**

1. Wait until helium stops evaporating and the quench valves are closed.
2. Wait until there is no helium vapor visible anywhere to make sure there is sufficient oxygen in the room.
3. Check that the globes in the quench valves are in the correct position.
4. Remove probe and shim system to prevent formation of ice on the shim system.
5. Start the refill with liquid helium as soon as possible.
6. Contact Bruker Service immediately.

# 7 Maintenance

Maintenance must be performed only with approved qualification. In case of doubt contact Bruker Service. For contact information see [page 7](#) of this document.

## 7.1 Safety

---

### Approved Persons

Bruker Service, Approved Customer Personnel



### WARNING

**Magnetic Field (see [page 17](#))**

**Cryogenic Agents (see [page 18](#))**

**Electricity (see [page 18](#))**

**Gas under Pressure (see [page 19](#))**

**Low Temperature (see [page 20](#))**

**Spontaneous Ignition and Explosion (see [page 20](#))**

### Personal protective equipment

Protective goggles

Protective gloves

Safety shoes

## 7.2 Cleaning

---

- Clean the RT vessel of the magnet system and the magnet stand with a dry or slightly damp cloth.
- Only use water and neutral detergents.
- Do not use volatile cleaning solvents.

## 7.3 Maintenance Timetable

Interval	Device	Work	Performed by
daily	Cryostat	Check the helium flow.	Approved Customer Personnel
daily	Cryostat	Check the nitrogen flow.	Approved Customer Personnel
weekly	Cryostat	<ul style="list-style-type: none"> <li>Check the helium level.</li> <li>Refill liquid helium if necessary. Follow the safety instructions of the supplied manual <i>Refilling Procedure</i> (Z31326).</li> <li>Record the filling session. A record of changes in the estimated consumption may be used for identification of problems. In this case contact Bruker Service.</li> </ul>	Approved Customer Personnel
weekly	Cryostat	<ul style="list-style-type: none"> <li>Check the nitrogen level.</li> <li>Refill liquid nitrogen if necessary. Follow the safety instructions of the supplied manual <i>Refilling Procedure</i> (Z31326).</li> <li>Weekly refill of liquid nitrogen is recommended.</li> <li>Record the filling session. A record of changes in the estimated consumption may be used to identify problems. In this case contact Bruker Service.</li> </ul>	Approved Customer Personnel

Table 7.1: Maintenance timetable

## 7.4 Maintenance-free Components

Interval	Device	Work	Performed by
- - -	Quench valves	<p>The quench valves are maintenance-free.</p> <ul style="list-style-type: none"> <li>However, in the event of a quench check the correct position of the globes in the quench valves.</li> </ul>	Approved Customer Personnel

Table 7.2: Maintenance-free components of the magnet system

# 8 Disassembling

Approved Persons: Bruker Service only



# 9 Technical Data MS 400'54 Ascend ULH

## 9.1 Environmental Conditions

---

	Value	Unit
Minimum surrounding temperature	7	°C
Maximum surrounding temperature	38	°C
Maximum relative humidity up to 31 °C	80	%
Maximum relative humidity between 31 °C and 40 °C linearly decreasing	80 – 50	%

Table 9.1: Environmental conditions

## 9.2 Identification Plate

---

The identification plate is on the right rear side attached to the bottom plate of the cryostat.

### Contents of the identification plate:

- Address of the Manufacturer
- Magnet System Identifier
- Type
- Magnet Identifier
- Serial Number
- Year of Construction
- Cryostat Identifier
- Specification Helium Vessel
- Specification Nitrogen Vessel
- Specification Vacuum Chamber
- Weight (empty and completely filled) including magnet stand

## 9.3 Dimensions

---

### 9.3.1 Weights

---

	Value	Unit
Weight magnet system (empty, without magnet stand)	378	kg
Weight magnet system (completely filled, without magnet stand)	504	kg
Operational weight (completely filled, with magnet stand)	600	kg
Weight magnet stand	96	kg
Weight magnet stand (ready for transportation, including box)	153	kg
Weight magnet system (empty, ready for transportation, including box and transportation locks)	510	kg

Table 9.2: Weight of the magnet system

### 9.3.2 Dimensions for Transportation

---

	L x W x H	Unit
Box with magnet system	114 x 93 x 199	cm <sup>3</sup>
Box with magnet stand	79 x 76 x 120	cm <sup>3</sup>

Table 9.3: Dimensions for transportation of the magnet system

9.3.3 Dimensions Cryostat

Front View

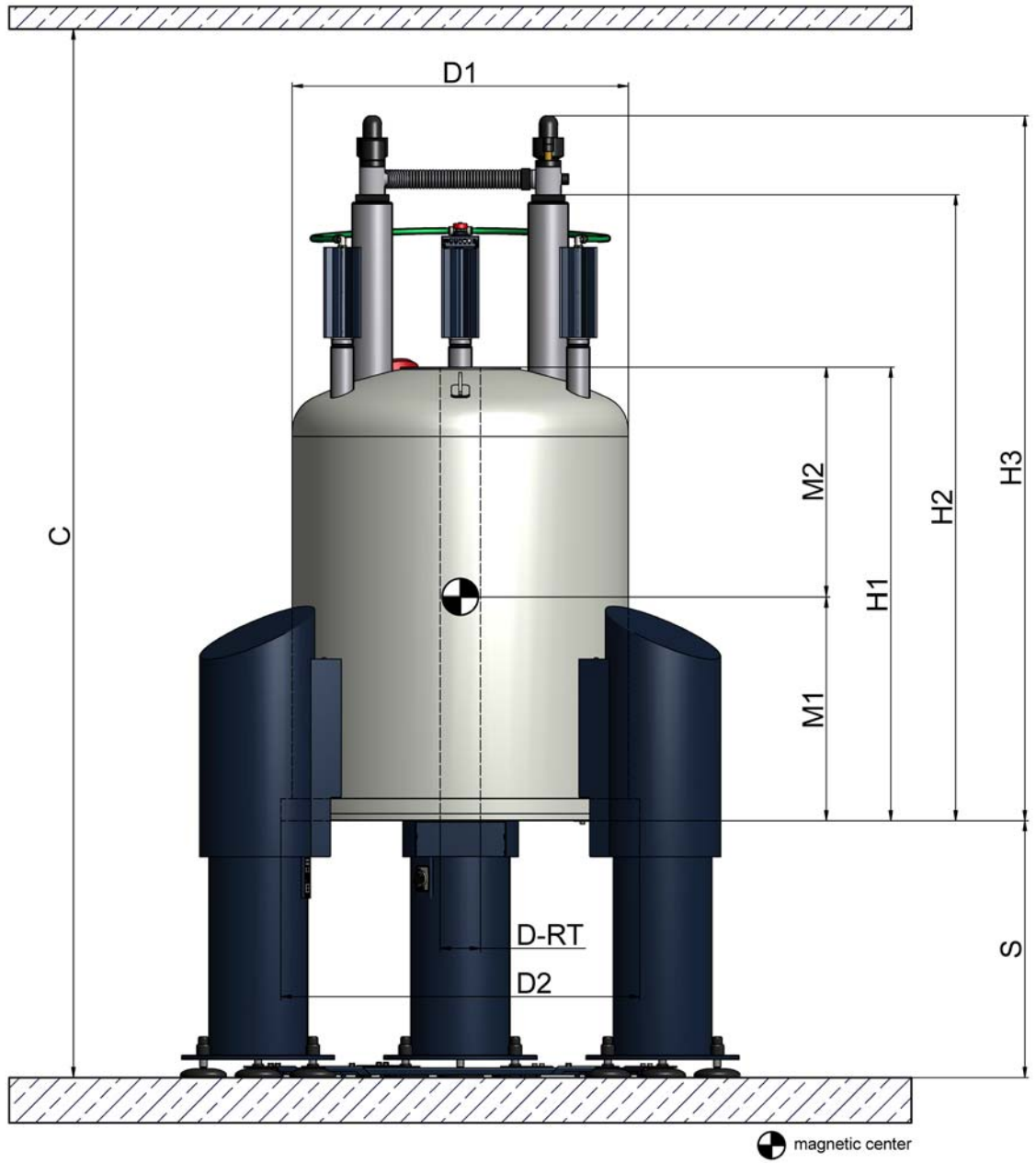

Figure 9.1: Dimensions of the cryostat (front view)

Dimensions Cryostat	Value	Unit
C Operational Ceiling Height	2715	mm
D-RT Diameter RT Bore Tube	54	mm
D1 Diameter RT vessel	745	mm
D2 Diameter Bottom Plate	795	mm
H1 Height Cryostat (bottom plate to top flange)	1205	mm
H2 Height Cryostat (minimum height for transportation)	1604	mm
H3 Height Cryostat (bottom plate to flow system)	1763	mm
S Height Magnet Stand (floor to bottom plate)	570	mm
M1 Distance magnetic center to bottom flange (calculated) Refer to <a href="#">Table 9.17 on page 77</a> for the measured distance of the magnetic center to bottom flange (MCB).	317	mm
M2 Distance magnetic center to top flange (calculated) Refer to <a href="#">Table 9.17 on page 77</a> for the measured distance of the magnetic center to top flange (MCT).	888	mm

Table 9.4: Dimensions of the cryostat – front view

## Top View

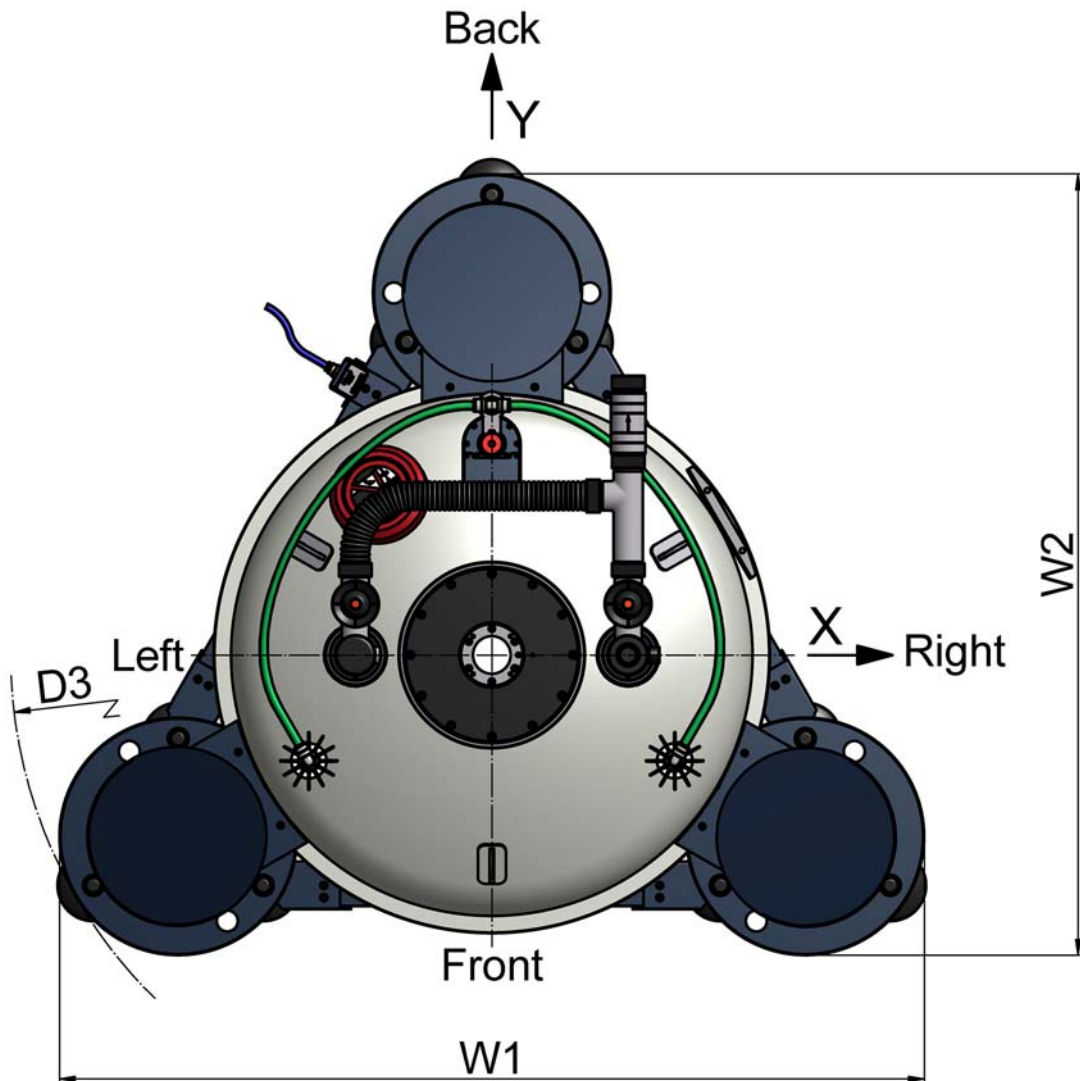

Figure 9.2: Dimensions of the cryostat (top view)

Cryostat Dimensions	Value	Unit
W1	1236	mm
W2	1116	mm
D3 *	1375	mm

Table 9.5: Dimensions of the cryostat – top view

\* Keep at least an additional free space of 1.5 m around the magnet system for service.

## 9.4 Safety Valves

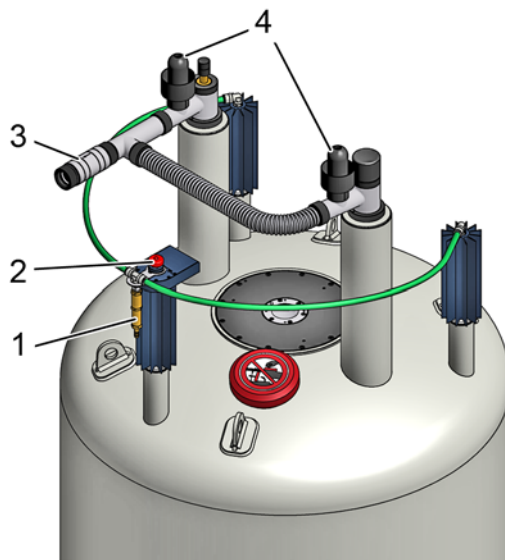

- 1 One-way valve of the nitrogen vessel
- 2 Safety valve of the nitrogen vessel
- 3 One-way valve of the helium vessel
- 4 Quench valve

Figure 9.3: Safety valves of the cryostat

Opening pressure	mbar	psi
One-way valve of the nitrogen vessel	10	0.15
Safety valve of the nitrogen vessel	138	2
One-way valve of the helium vessel	15	0.21
Quench valve	180	2.6

Table 9.6: Opening pressure of the safety valves of the magnet system

## 9.5 Nitrogen Level Sensor

The Nitrogen Level Sensor is inserted in the recommended nitrogen turret. 5 lights display the nitrogen level (see [Figure 9.4:](#)).

Nitrogen Level Sensor	Material No.	Value	Unit
Level Sensor Type	Z122404	12/1126/860 D325	
Diameter		12	mm
Overall length		1126	mm
Active length		860	mm

Table 9.7: Nitrogen level sensor

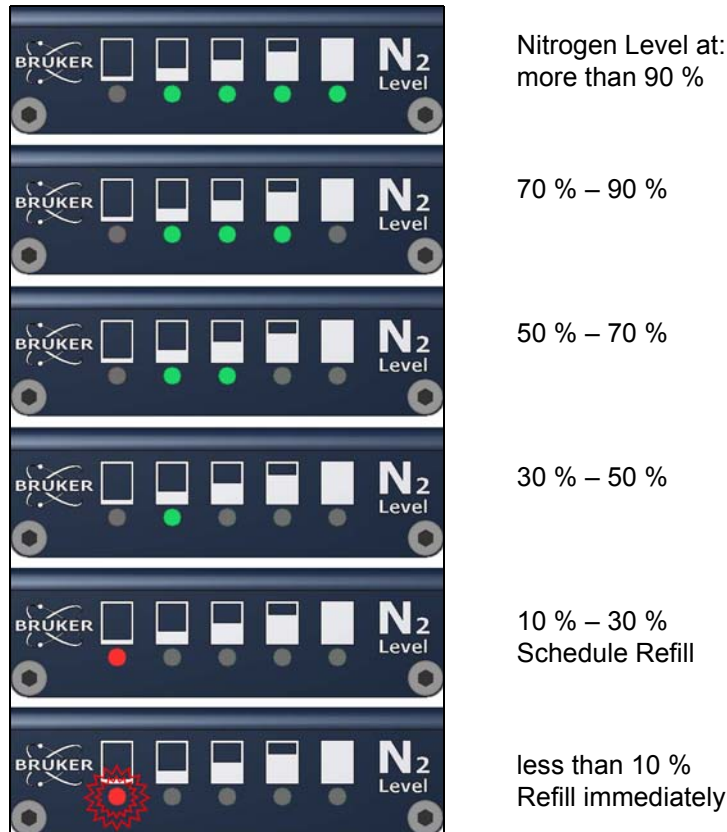

Figure 9.4: Nitrogen level sensor

## 9.6 Helium Level Sensor

The Helium Level Sensor is inserted in the helium fill-in turret.

Helium Level Sensor	Material No.	Value	Unit
Level Sensor Type	Z58103	1500/874 D37X	
Overall length		1500	mm
Active length		874	mm
Calibration 0 %, Calibration resistor	Z53168 violet	177	$\Omega$
Calibration 100 %, Calibration resistor	Z28628 black	15	$\Omega$

Table 9.8: Helium level sensor

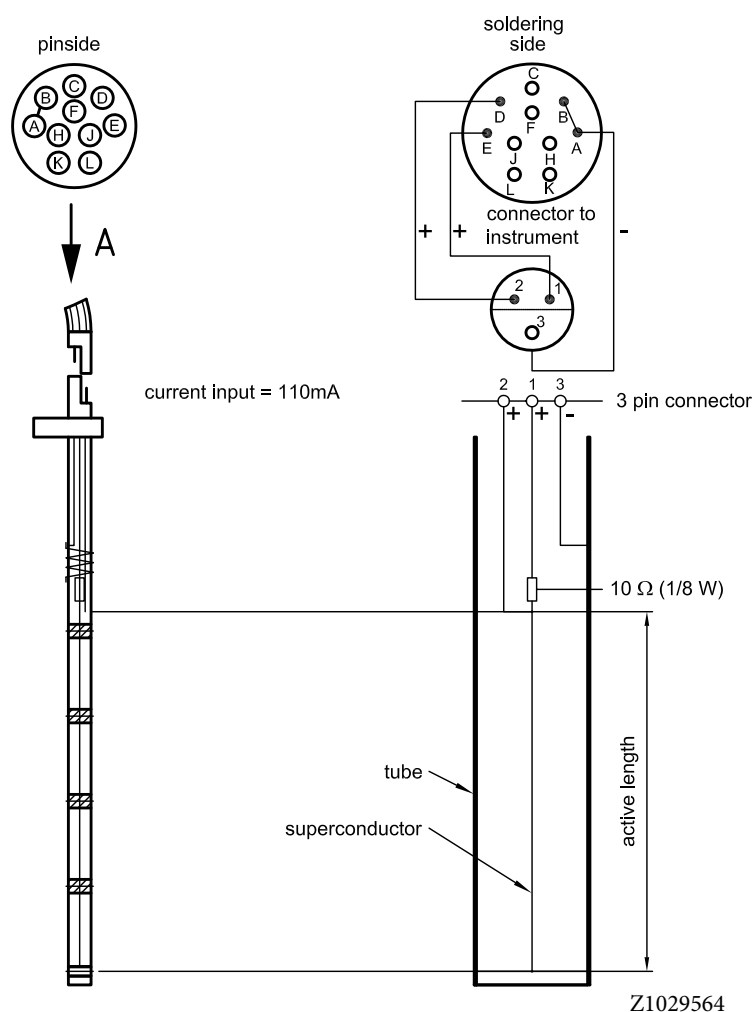

Figure 9.5: Helium level sensor

## 9.7 Temperature Sensors

The temperature sensors (PT 100 and IBT) are used to monitor the temperature of the magnet during cooling down and warming up the magnet system.

### PT 100 Sensor



Measure the resistance with a maximum current of 1 mA.

	Temperature	Unit	Resistance	Unit
Room Temperature	293	K	107.8	$\Omega$
	273	K	100.0	$\Omega$
	250	K	91.0	$\Omega$
	200	K	71.1	$\Omega$
	150	K	50.9	$\Omega$
	100	K	30.0	$\Omega$
Liquid Nitrogen	77	K	20.1	$\Omega$

Table 9.9: Characteristic values of PT 100 sensor

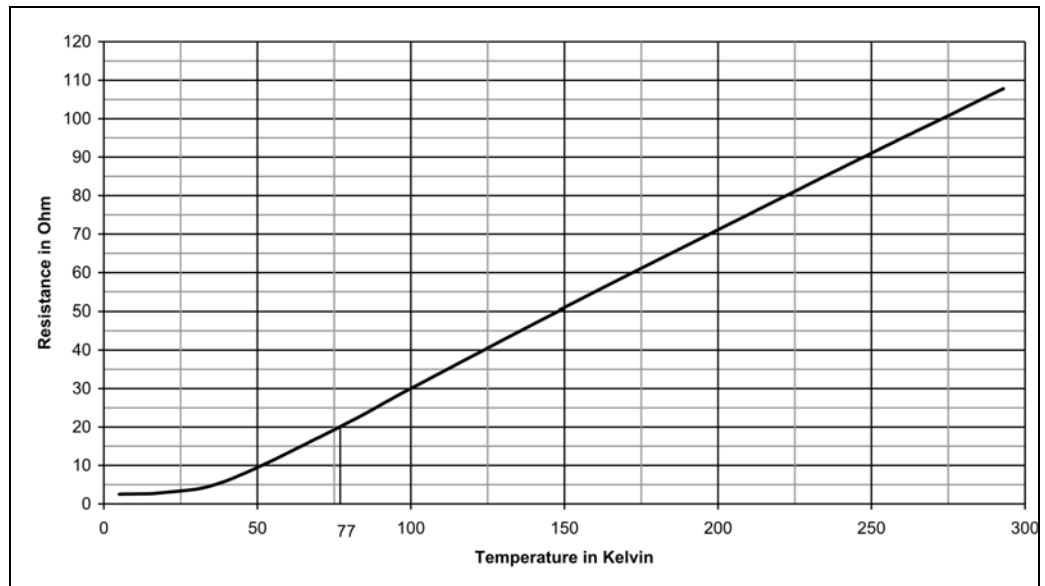

Figure 9.6: Characteristic curve of PT 100 sensor

## IBT Carbon Resistor



Measure the resistance with a maximum current of 0.1 mA.

	Temperature	Unit	Resistance	Unit
Room Temperature	300	K	220	$\Omega$
Liquid Nitrogen	77	K	265	$\Omega$
	40	K	300	$\Omega$
	20	K	350	$\Omega$
	10	K	420	$\Omega$
	8	K	450	$\Omega$
	6	K	500	$\Omega$
	5	K	540	$\Omega$
Liquid Helium	4.2	K	575	$\Omega$

Table 9.10: Characteristic values of IBT carbon sensor

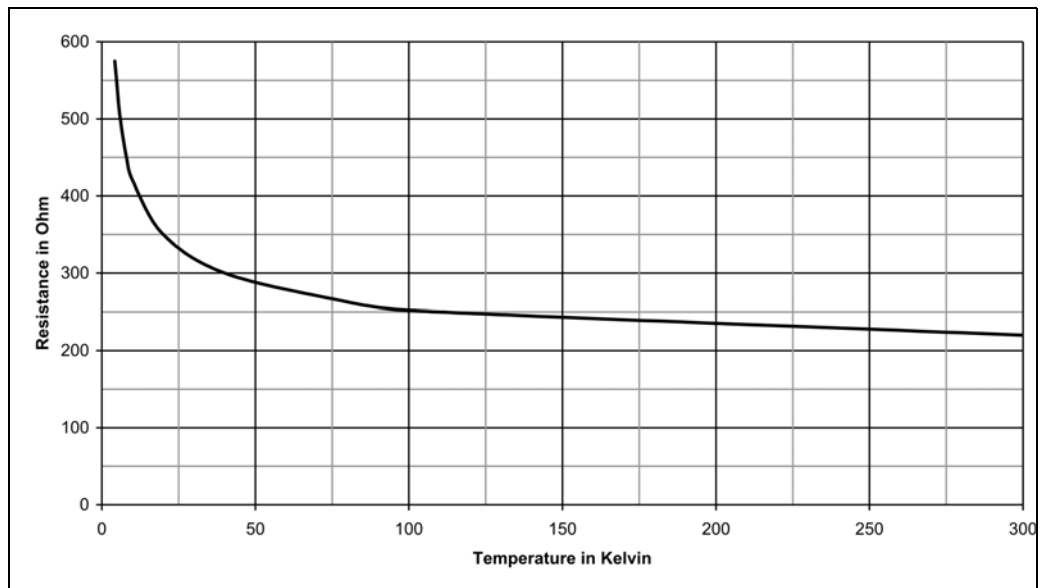

Figure 9.7: Characteristic curve of IBT carbon sensor

This page will be replaced by specific technical data.

## 9.8 Technical Data Magnet

Technical Data Magnet	Value	Unit
Proton frequency	400	MHz
Central field	9.4	T
Coil inductance	30.4	H
Magnetic energy	164.5	kJ
Maximum drift rate	0.01	ppm/h
	4	Hz/h

Table 9.11: Specification of the magnet

### Operating Modes of the Magnet System:

#### Driven Mode

In the driven mode the current lead is mounted and the current is led through the power supply. The coils of the magnet can be energized and deenergized.

#### Persistent Mode

In the persistent mode the current flows exclusively within the magnet. The circuit has no connection to the outside. The magnetic field cannot be switched off.

### 9.9 Fringe Field Plot

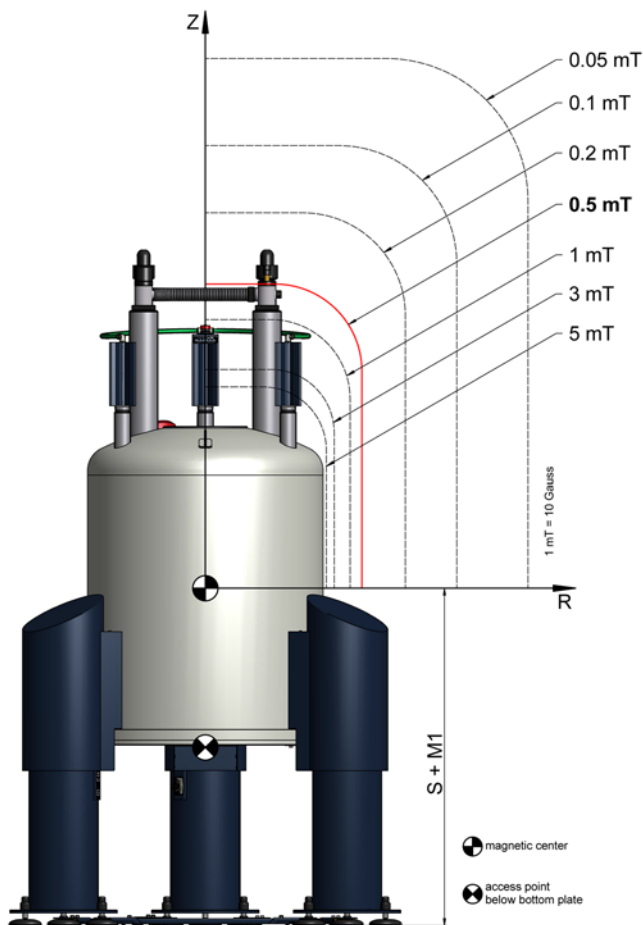

Figure 9.8: Fringe field plot of the magnet system at maximum field

Fringe Field	Unit	R max	Unit	Z max	Unit
200	mT	0.21	m	0.35	m
5.0	mT	0.37	m	0.64	m
3.0	mT	0.40	m	0.70	m
1.0	mT	0.46	m	0.87	m
<b>0.5 (5 Gauss)</b>	<b>mT</b>	<b>0.50</b>	<b>m</b>	<b>1.00</b>	<b>m</b>
0.2	mT	0.62	m	1.23	m
0.1	mT	0.78	m	1.46	m
0.05	mT	1.00	m	1.75	m
max. magnetic field B0 at access point				275.1	mT
max. field gradient dB/dz at access point				5.3	T/m

Table 9.12: Fringe field data of the magnet system at maximum field

This page will be replaced by specific technical data.

## 9.10 Filling Volume, Evaporation Rate and Hold Time

### Cryogenic Consumption during Installation

The consumption of liquid cryogenic agents during installation consists of consumption for cooling down the cryostat, for energizing, cryo shimming and quench reserve.

Cryogenic Agents Consumption	Value	Unit
Nitrogen	500	l
Helium (needed for cool down)	300	l
Helium (needed for energizing, cryo shimming and quench reserve)	300	l

Table 9.13: Cryogenic agents consumption during installation

Cryogenic Agents	Value	Unit
Nitrogen vessel total volume	134	l
Nitrogen refill volume	104	l
Nitrogen evaporation rate	240	ml/h
Nitrogen hold time <sup>1</sup>	18	days
Helium vessel total volume	142	l
Helium refill volume	127	l
Helium evaporation rate	14.5	ml/h
Helium hold time <sup>1</sup>	365	days
Helium refill volume after quench (cool down and refill)	150	l

Table 9.14: Cryogenic agents

<sup>1</sup> Maximum time interval between two fillings

9.11 Nitrogen Level Graph

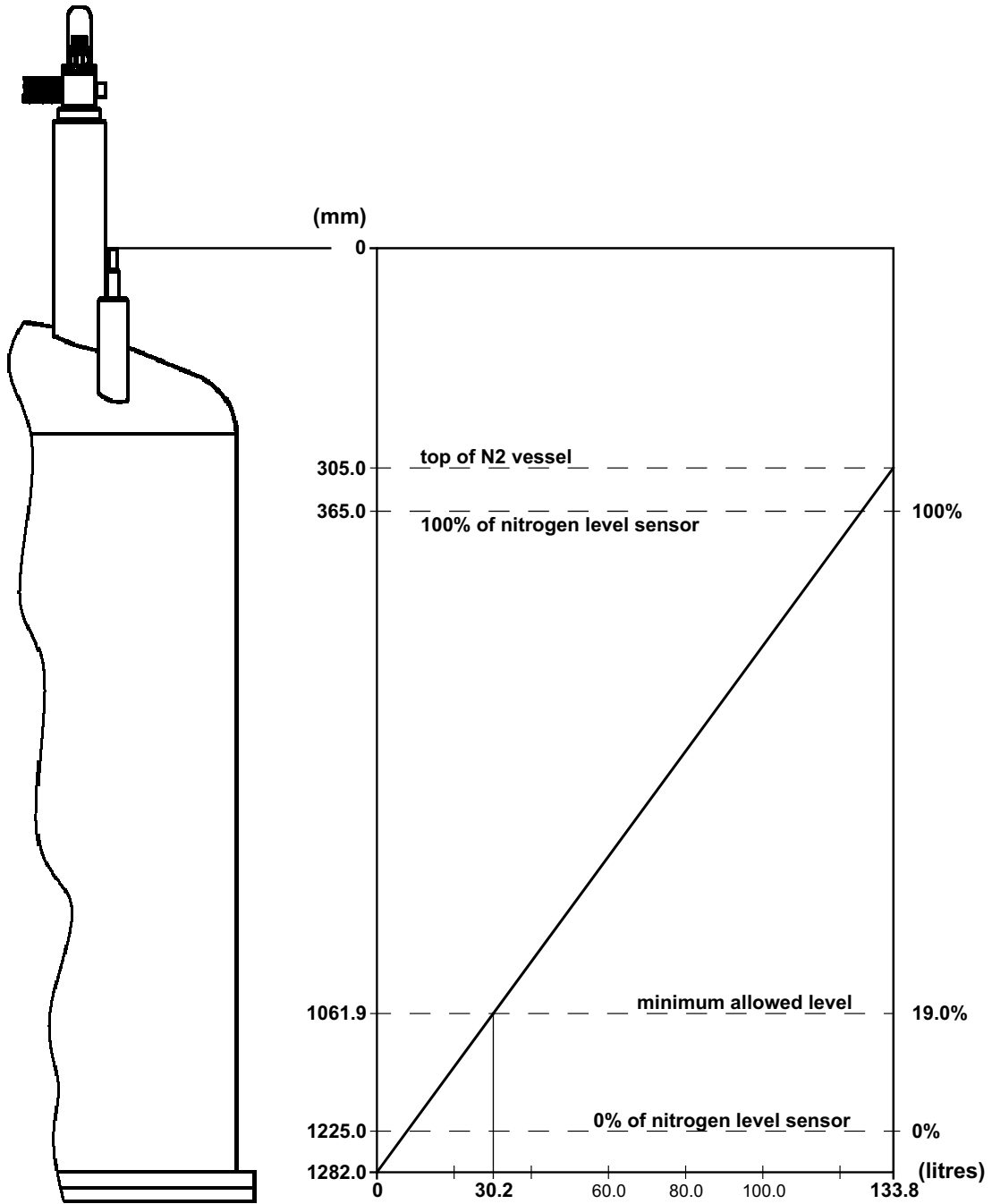

Figure 9.9: Nitrogen level graph

This page will be replaced by specific technical data.

9.12 Helium Level Graph

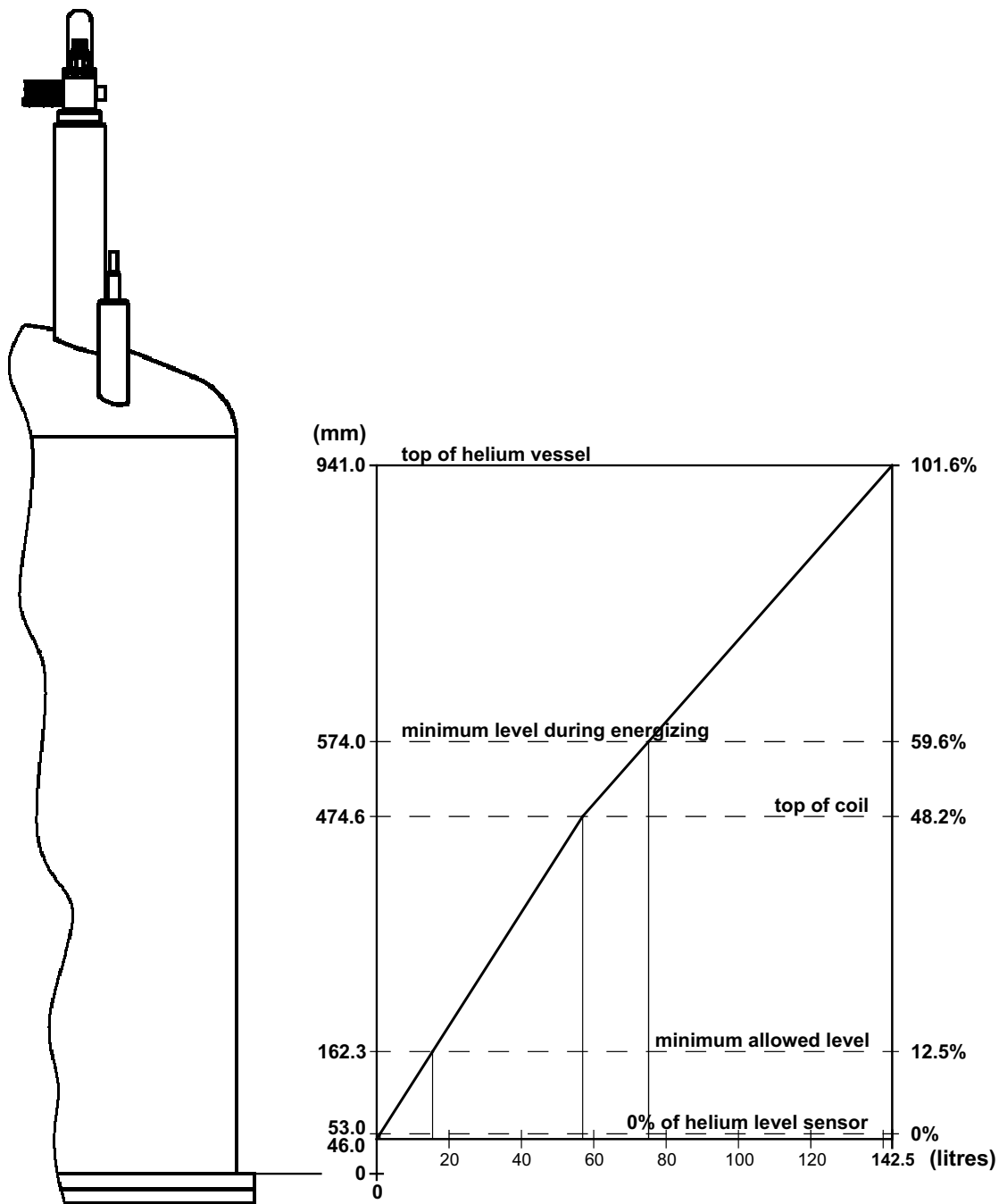

Figure 9.10: Helium level graph

## 9.13 Resistance at Room Temperature

Current lead used to energize magnet:

Current Lead, 55 Pin 200 A (grey)		
---	--	--

	Pin	Connector	Description	Value	Unit
From: To:	PIN V PIN S	19 PIN Con CONTROL 19 PIN Con CONTROL	Main Heater		Ω
From: To:	PIN D PIN S	19 PIN Con CONTROL 19 PIN Con CONTROL	Z Heater		Ω
From: To:	PIN G PIN S	19 PIN Con CONTROL 19 PIN Con CONTROL	X Heater		Ω
From: To:	PIN H PIN S	19 PIN Con CONTROL 19 PIN Con CONTROL	Y Heater		Ω
From: To:	PIN J PIN S	19 PIN Con CONTROL 19 PIN Con CONTROL	XZ Heater		Ω
From: To:	PIN K PIN S	19 PIN Con CONTROL 19 PIN Con CONTROL	YZ Heater		Ω
From: To:	PIN N PIN S	19 PIN Con CONTROL 19 PIN Con CONTROL	XY Heater		Ω
From: To:	PIN P PIN S	19 PIN Con CONTROL 19 PIN Con CONTROL	X <sup>2</sup> -Y <sup>2</sup> Heater		Ω
From: To:	PIN E PIN S	19 PIN Con CONTROL 19 PIN Con CONTROL	Z <sup>2</sup> Heater		Ω
From: To:	PIN C,D,E,F PIN B,G,J,K	10 PIN Con SHIM 10 PIN Con SHIM	Shim Coils +/-		Ω
From: To:	PIN C,D,E,F PIN S	10 PIN Con SHIM 19 PIN Con CONTROL	Shim Coil + to Heater (common)		Ω
From: To:	+ PIN T	High current Con 19 PIN Con CONTROL	High Current + to Sense +		Ω
From: To:	+ -	High current Con High current Con	Main Coil		Ω
From: To:	- PIN U	High current Con 19 PIN Con CONTROL	High Current - to Sense -		Ω
From: To:	PIN F PIN S	19 PIN Con CONTROL 19 PIN Con CONTROL	Z <sup>3</sup> Heater		Ω
From: To:	PIN T PIN U	19 PIN Con CONTROL 19 PIN Con CONTROL	Sense + Sense -		Ω
From: To:	PIN C,D,E,F PIN T	10 PIN Con SHIM 19 PIN Con CONTROL	Shim Coil + to Sense +		Ω
From: To:	PIN T PIN S	19 PIN Con CONTROL 19 PIN Con CONTROL	Sense + to Heater (common)		Ω
From: To:	PIN K PIN H	10 PIN cool down Con 10 PIN cool down Con	Upper temperature sensor PT 100		Ω
From: To:	PIN A PIN K	10 PIN cool down Con 10 PIN cool down Con	IBT Carbon temperature sensor		Ω
From: To:	PIN A PIN B	10 PIN cool down Con 10 PIN cool down Con	Lower temperature sensor PT100		Ω
From: To:		All Connectors Ground	Insulation Magnet to Cryostat		Ω

Table 9.15: Resistance at room temperature

This page will be replaced by specific technical data.

### 9.14 Heater Currents

Heater Currents	Value	Unit
Main heater current		mA
Shim heater current		mA

Table 9.16: Heater currents

### 9.15 Shim Switch Heater

Heater operation during energizing / deenergizing

Shim Switch	Heater Operation
Z <sup>0</sup>	not detected
Z <sup>1</sup>	automatic
Z <sup>2</sup>	permanent
Z <sup>3</sup>	automatic
X	automatic
Y	automatic
XZ	automatic
YZ	automatic
XY	automatic
X <sup>2</sup> -Y <sup>2</sup>	automatic

Table 9.17: Shim switch heater operation

## 9.16 Energizing Assignment and Currents

Check the minimum level during energizing (see [Helium Level Graph on page 73](#)).

Energizing Currents [A]			Sense Voltage [mV]	Remarks Bruker Test Site
0	to	85.01	2500	
85.01	to	100.01	500	
100.01	to	104.04	200	
<b>Overshoot (0.3 % of final current)</b>				
104.04 Final current	to	104.25 Overshoot	50	
<b>10 minutes break at overshoot current</b>				
104.25 Overshoot	to	104.04 Final current	50	
<b>Total energizing time [min]</b>				
57				
<b>Rate of current ramp-down with magnet in persistent mode [A/min]</b>				
20				
<b>Mandatory wait time between energizing and shimming [h]</b>				
18				

Table 9.18: Energizing assignment and currents

This page will be replaced by specific technical data.

### 9.17 Magnetic Center

Magnetic Center	Value	Unit
Distance magnetic center from top flange (MCT)		mm
Distance magnetic center from bottom flange (MCB)		mm
Shim system Offset (SO) see <a href="#">Figure 9.11</a> : and refer to the supplied Test Protocol AST		mm

Table 9.19: Magnetic center

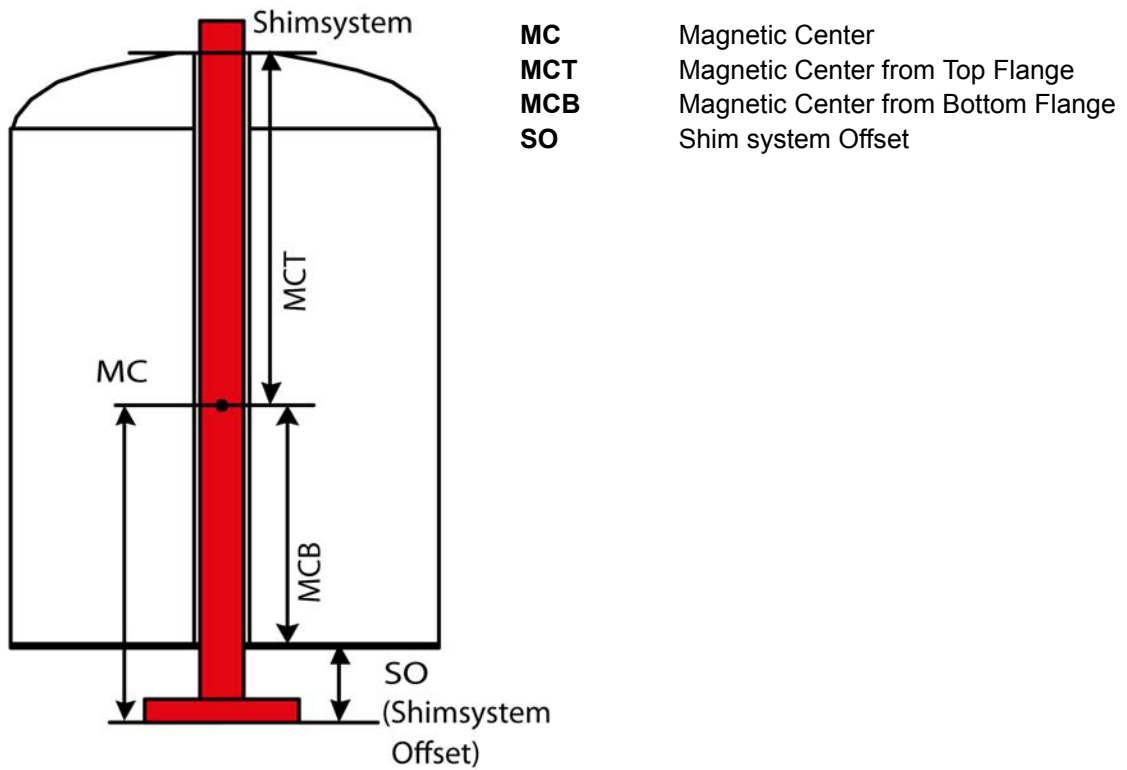

Figure 9.11: Magnetic center and shim system offset (SO)

This page will be replaced by specific technical data.

## 9.18 Cycling Assignment and Shim Currents

Cycling is recommended only for magnet systems at 500 MHz and more.

Shim Currents	Value	Unit
Shim current rate		A/min
Z <sup>1</sup> Shim current		A
Z <sup>2</sup> Shim current		A
Z <sup>3</sup> Shim current		A
X Shim current		A
Y Shim current		A
XZ Shim current		A
YZ Shim current		A
XY Shim current		A
X <sup>2</sup> -Y <sup>2</sup> Shim current		A
Frequency change due to cycling		kHz
Date and Signature		

Table 9.20: Cycling assignment and shim currents

This page will be replaced by specific technical data.

-----Cryo

### 9.19 Cryo Shim Currents

Cryo Shim Currents	Value at Customer Site #1	Value at Customer Site #2	Value at Customer Site #3	Value at Customer Site #4	Unit
Z <sup>1</sup> Shim current					A
Z <sup>2</sup> Shim current					A
Z <sup>3</sup> Shim current					A
X Shim current					A
Y Shim current					A
XZ Shim current					A
YZ Shim current					A
XY Shim current					A
X <sup>2</sup> -Y <sup>2</sup> Shim current					A
Shim system Offset design value	Refer to the supplied Test Protocol AST				mm
Shim system Offset Customer Site value					mm
Date and Signature					

Table 9.21: Cryo shim currents

### 9.20 Deenergizing Assignment and Currents

Deenergizing Currents [A]			Sense Voltage [mV]	Remarks Bruker Test Site
104.03	to	102.00	200	
102.00	to	95.00	500	
95	to	0	1400	
<b>Total deenergizing time [min]</b>				
47				

Table 9.22: Deenergizing assignment and currents

*This page will be replaced  
by specific technical data.*

This page is intentionally left blank.

9.21 Current Lead

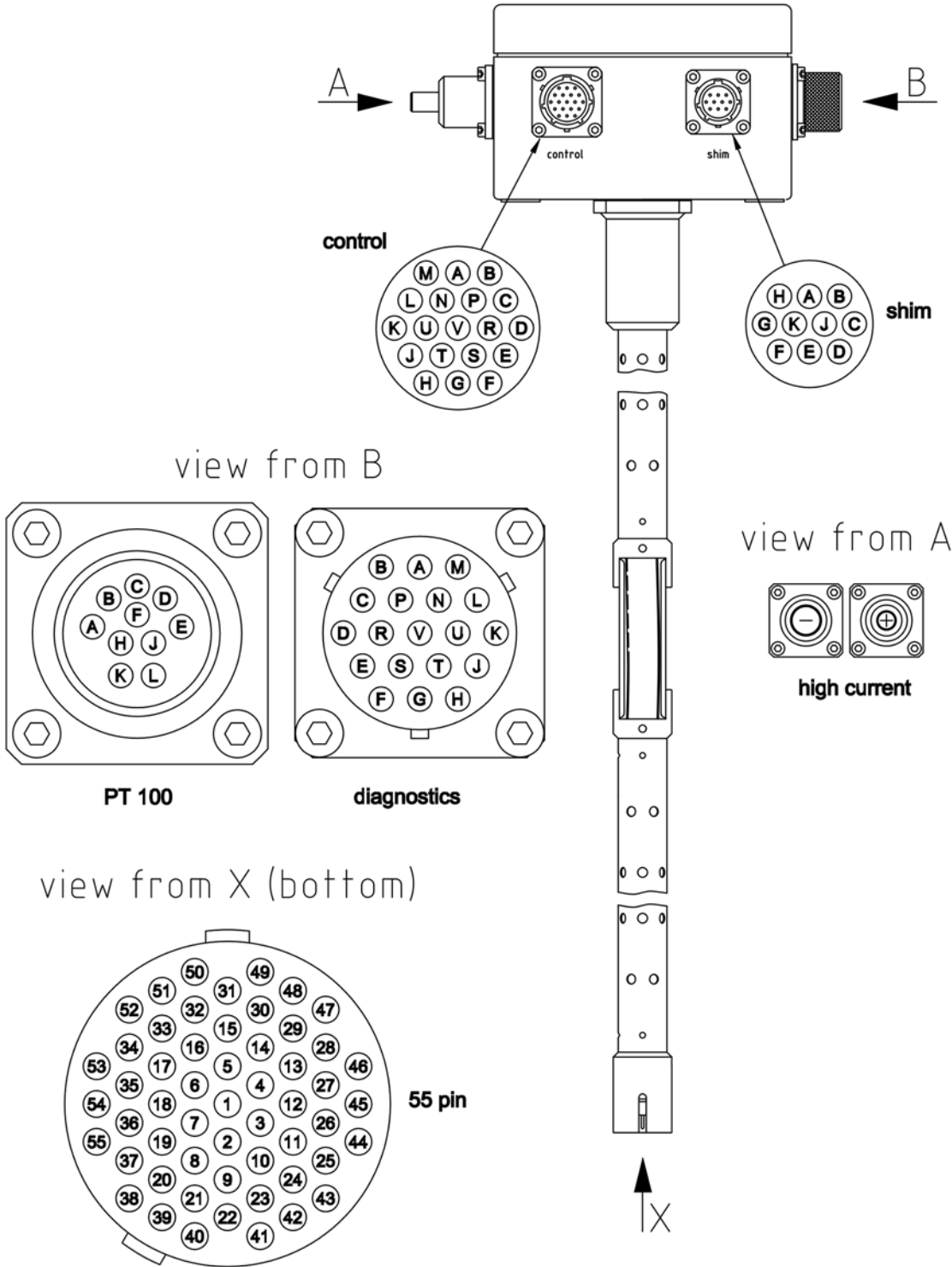

Z1029367

Figure 9.12: Current lead 55 pin

## 9.21.1 Wiring Diagram Magnet

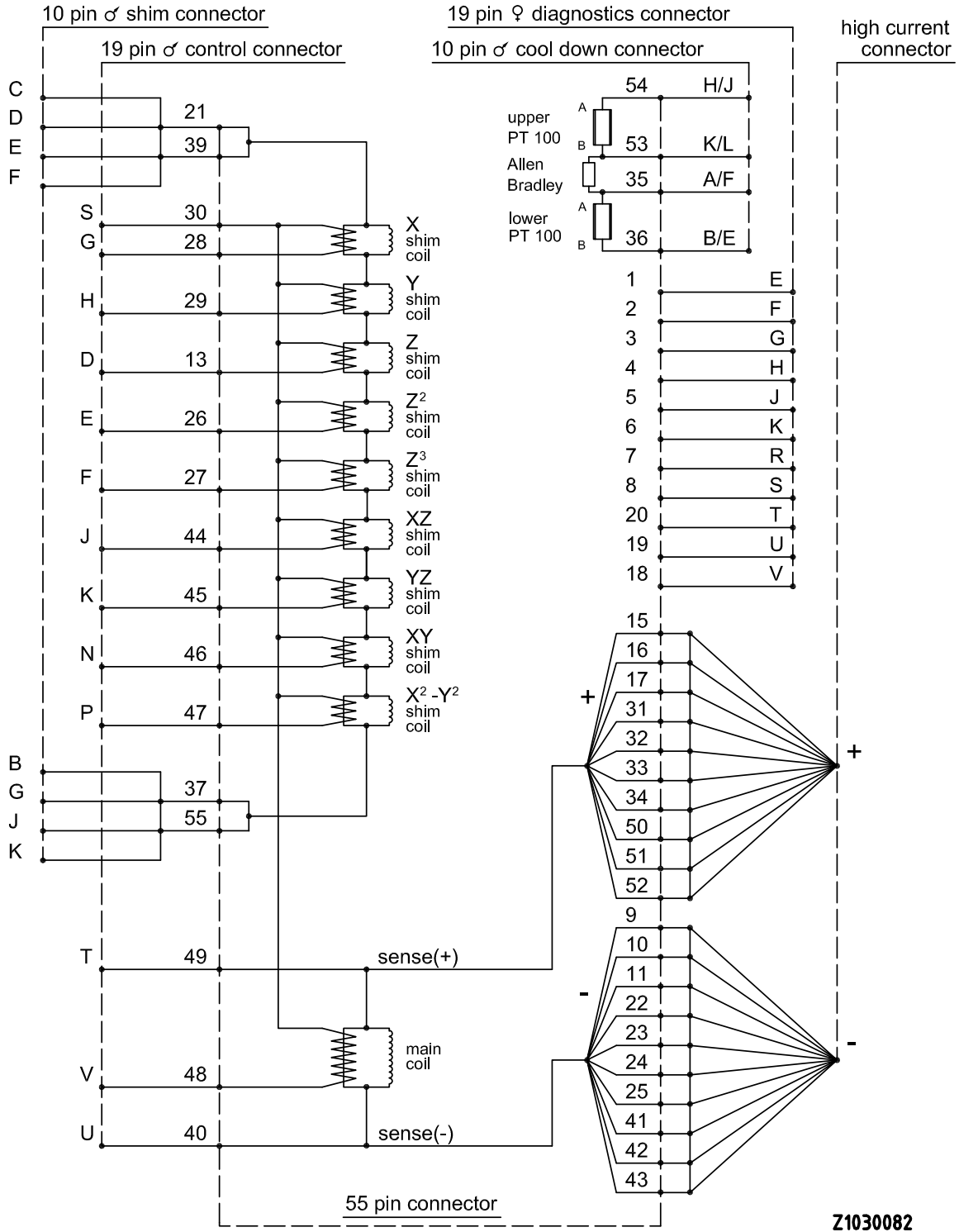
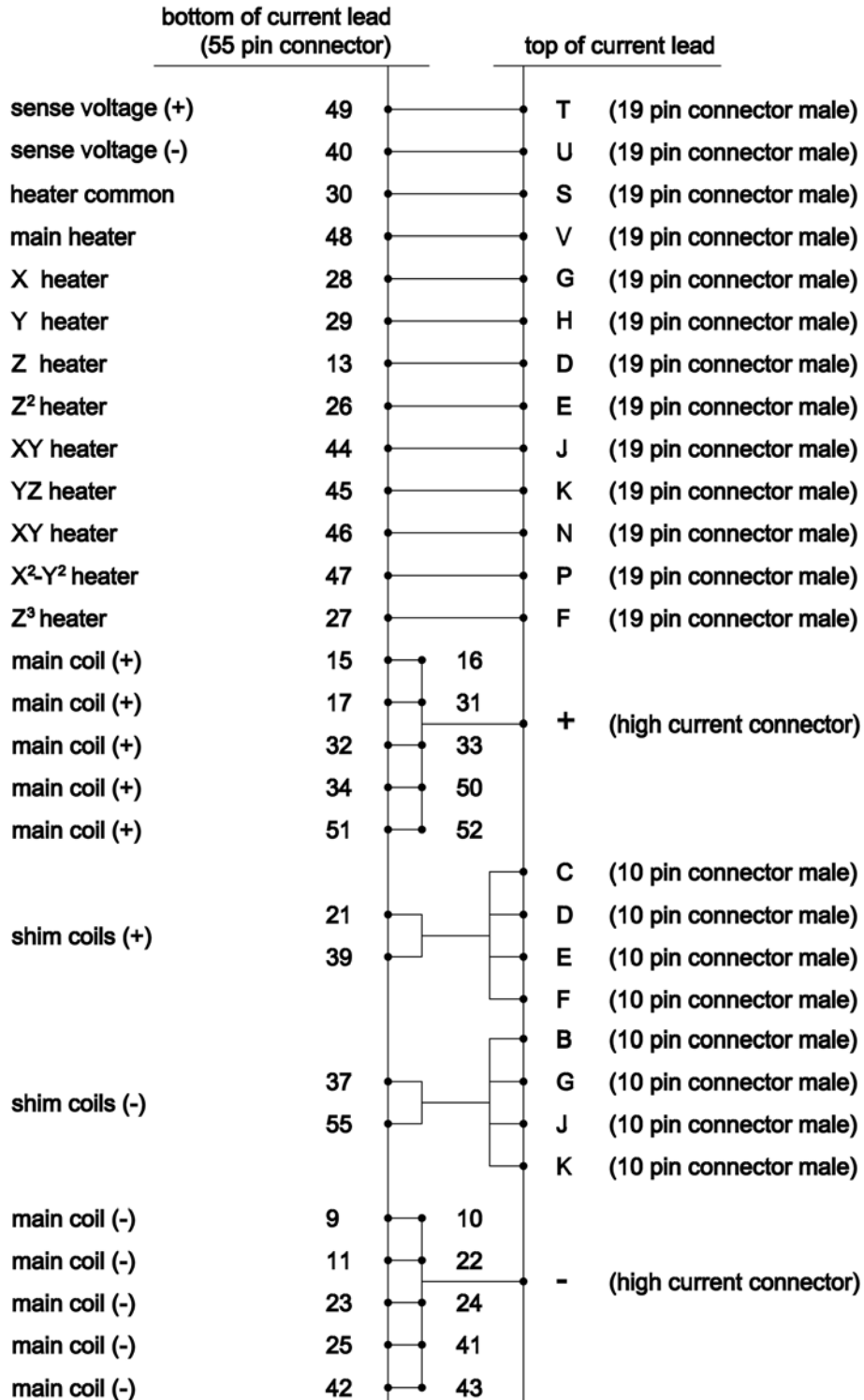

Figure 9.13: Wiring diagram magnet

## 9.21.2 Wiring Diagram of Current Lead - Magnet Control and Shims



Z1029391

Figure 9.14: Wiring diagram of current lead - magnet control and shims

## 9.21.3 Wiring Diagram of Current Lead 55 Pin - Cool Down and Diagnostics

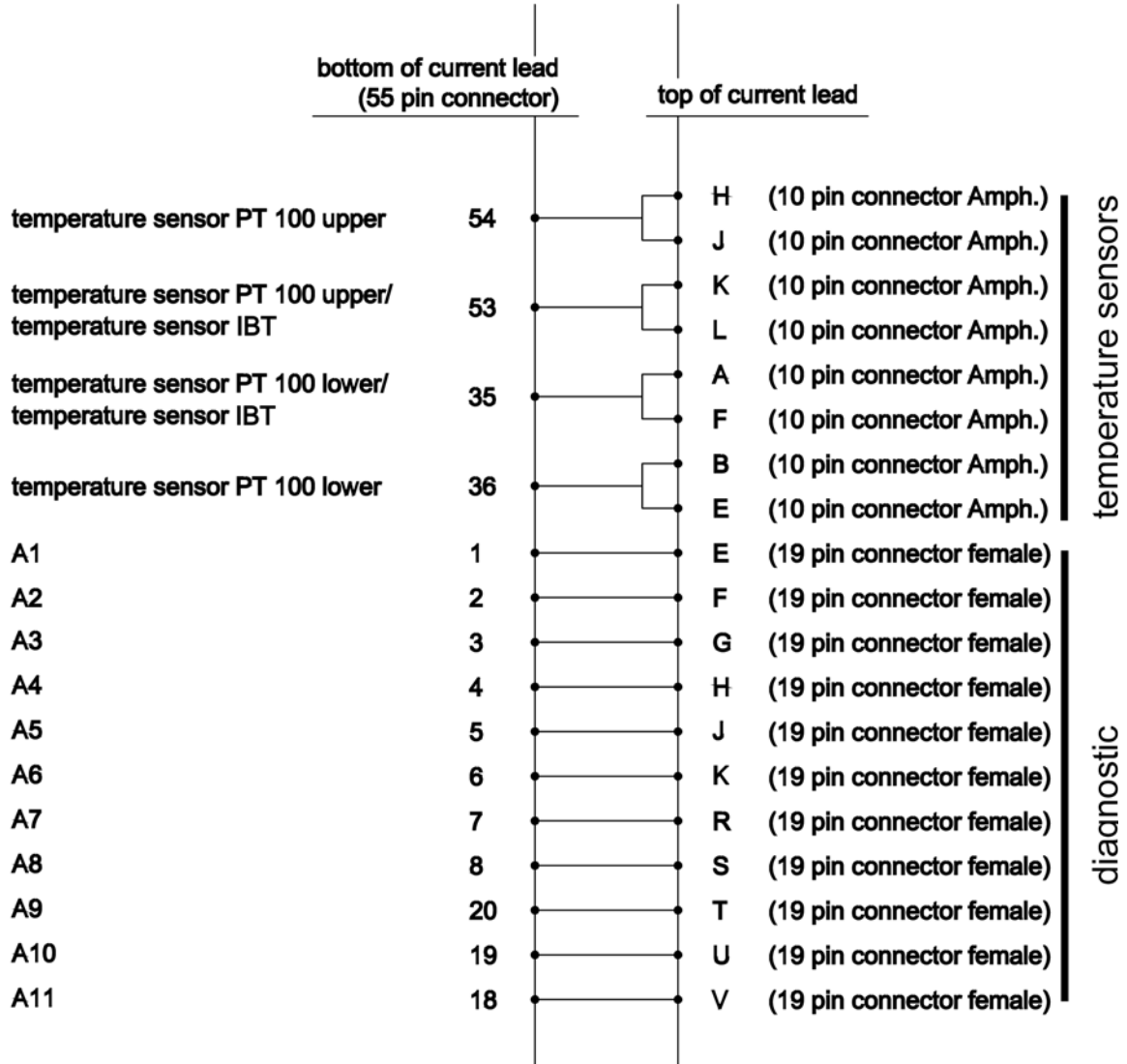

Z1029392

Figure 9.15: Wiring diagram of current lead - cool down and diagnostics

## 9.21.4 Shorting Plug

The shorting plug is plugged after removal of the current lead. After inserting the shorting plug the current flows through the shorting plug and no longer through the current lead and the power supply.

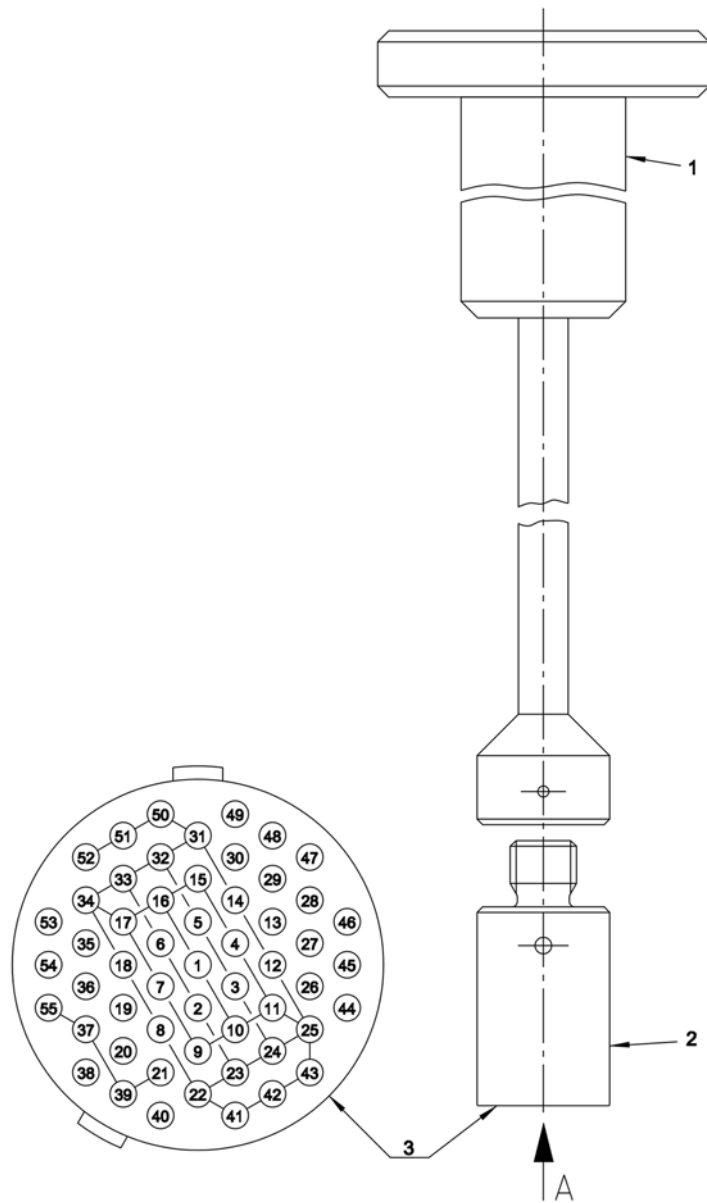

Z1029521

Figure 9.16: Shorting plug 55 pins

- 1 Shorting Plug Tool for fitting and removing the shorting plug
- 2 Shorting Plug
- 3 Shorting Plug - view from pin side











# Appendix A

## A.1 Warning Signs

---

### **Danger**

Key Word and Symbol .....	13
---------------------------	----

### **Warning**

Cryogenic Agents .....	18
Electricity .....	18
Gas under Pressure .....	19
Heavy Weights .....	21
Intended Use .....	15
Key Word and Symbol .....	13
Low Temperature .....	20
Magnetic Field .....	17
Persons .....	15
Quench .....	19
Safety Devices .....	16
Signs and Labels .....	17
Slippage .....	20
Spare Parts .....	16
Spontaneous Ignition and Explosion .....	20

### **Caution**

Incorrect Transportation .....	22
Key Word and Symbol .....	13

### **Notice**

Key Word and Symbol .....	14
---------------------------	----

### **Safety Instructions**

Key Word and Symbol .....	14
---------------------------	----



## A.2 Figures

---

Figure 1.1:	General view of a magnet system with 2 helium turrets .....	10
Figure 2.1:	Safety devices of the cryostat with 2 helium turrets .....	25
Figure 3.1:	Packaging (without surrounding panels) .....	29
Figure 3.2:	Transportation by fork lift – front view .....	31
Figure 3.3:	Transportation by fork lift – rear view .....	31
Figure 3.4:	Attachment points for lifting equipment .....	32
Figure 3.5:	Instruction label for lifting equipment .....	32
Figure 5.1:	Start the magnet stand .....	38
Figure 5.2:	Stop the magnet stand .....	38
Figure 6.1:	Magnet system during a quench .....	54
Figure 9.1:	Dimensions of the cryostat (front view) .....	61
Figure 9.2:	Dimensions of the cryostat (top view) .....	63
Figure 9.3:	Safety valves of the cryostat .....	64
Figure 9.4:	Nitrogen level sensor .....	65
Figure 9.5:	Helium level sensor .....	66
Figure 9.6:	Characteristic curve of PT 100 sensor .....	67
Figure 9.7:	Characteristic curve of IBT carbon sensor .....	68
Figure 9.8:	Fringe field plot of the magnet system at maximum field .....	70
Figure 9.9:	Nitrogen level graph .....	72
Figure 9.10:	Helium level graph .....	73
Figure 9.11:	Magnetic center and shim system offset (SO) .....	77
Figure 9.12:	Current lead 55 pin .....	81
Figure 9.13:	Wiring diagram magnet .....	82
Figure 9.14:	Wiring diagram of current lead - magnet control and shims .....	83
Figure 9.15:	Wiring diagram of current lead - cool down and diagnostics .....	84
Figure 9.16:	Shorting plug 55 pins .....	85



### A.3 Tables

---

Table 7.1:	Maintenance timetable .....	56
Table 7.2:	Maintenance-free components of the magnet system .....	56
Table 9.1:	Environmental conditions .....	59
Table 9.2:	Weight of the magnet system .....	60
Table 9.4:	Dimensions of the cryostat – front view .....	62
Table 9.5:	Dimensions of the cryostat – top view .....	63
Table 9.6:	Opening pressure of the safety valves of the magnet system .....	64
Table 9.7:	Nitrogen level sensor .....	65
Table 9.8:	Helium level sensor .....	66
Table 9.9:	Characteristic values of PT 100 sensor .....	67
Table 9.10:	Characteristic values of IBT carbon sensor .....	68
Table 9.11:	Specification of the magnet .....	69
Table 9.12:	Fringe field data of the magnet system at maximum field .....	70
Table 9.13:	Cryogenic agents consumption during installation .....	71
Table 9.14:	Cryogenic agents .....	71
Table 9.15:	Resistance at room temperature .....	74
Table 9.16:	Heater currents .....	75
Table 9.17:	Shim switch heater operation .....	75
Table 9.18:	Energizing assignment and currents .....	76
Table 9.19:	Magnetic center .....	77
Table 9.20:	Cycling assignment and shim currents .....	78
Table 9.21:	Cryo shim currents .....	79
Table 9.22:	Deenergizing assignment and currents .....	79



## A.4 Index

---

### A

Access Point .....	70
Attachment Points .....	32

### C

Cleaning Staff .....	12
Complaint Process .....	30
Cryogenic Agents .....	17, 18
Cryostat .....	10, 25

### D

Disposal .....	33
Disturbances .....	49
Driven Mode .....	69
Drop-off Plate .....	26

### E

Electricity .....	18
Emergency .....	27
Emergency Exit .....	24
Evaporation Rate .....	71

### F

Filling Volume .....	71
Fire Department .....	27
First Aid for Cold Burns .....	27
Fringe Field Plot .....	70

### H

Helium Level Graph .....	73
Helium Level Sensor .....	66
Hold Time .....	71

### I

IBT Carbon Resistor .....	68
Identification Plate .....	59
Intended Use .....	15

### L

Liability .....	9
Low Temperature .....	20

### M

Magnetic Center .....	77
Magnetic Field .....	17

### N

Nitrogen Level Graph .....	72
----------------------------	----

### O

One-way Valves .....	26
----------------------	----

### P

Persistent Mode .....	69
Portable Oxygen Monitor .....	23
Protective Clothes .....	23
Protective Gloves .....	23
Protective Goggles .....	23
PT 100 Sensor .....	67

### Q

Quench .....	19, 54
Quench Valve .....	26

### R

Rescue Equipment .....	27
------------------------	----

### S

Safety Devices .....	25
Safety Shoes .....	23
Safety Valve .....	26
Shim system Offset (SO) .....	77
Shock Watch .....	30
Slippage .....	20
Spontaneous Ignition .....	20

### T

Technical Data .....	59
Tilt Watch .....	30
Tilting .....	21
Transportation .....	22

### W

Warranty .....	9
Weights .....	60
Wiring Diagram Magnet .....	82



## Revision History List

<b>Index:</b>	<b>Date:</b>	<b>Alteration Type:</b>
00	October 2010	First release.
01	September 2012	Update of fringe field data and related directives.
02	February 2013	Update of magnetic center.
03	June 2013	New layout of title page and last page.
04	August 2017	Update of Technical Data; inserted shim-system offset, shim switch heater operation and mandatory wait time after energizing. Update of magnet stand weight, magnet system total weight, fringe field data and Helium flow system. Added references to manual <i>Refilling Procedure</i> .
05	February 2019	New calculation of Nitrogen minimum allowed level.



**Bruker Corporation**

[info@bruker.com](mailto:info@bruker.com)  
[www.bruker.com](http://www.bruker.com)

Order No: Z31990